

IGLOO nano Low Power Flash FPGAs with Flash*Freeze Technology



Features and Benefits

Low Power

- nanoPower Consumption—Industry's Lowest Power
- 1.2 V to 1.5 V Core Voltage Support for Low Power
- Supports Single-Voltage System Operation
- Low Power Active FPGA Operation
- Flash*Freeze Technology Enables Ultra-Low Power Consumption while Maintaining FPGA Content
- Easy Entry to / Exit from Ultra-Low Power Flash*Freeze Mode

Small Footprint Packages

- As Small as 3x3 mm in Size

Wide Range of Features

- 10,000 to 250,000 System Gates
- Up to 36 kbits of True Dual-Port SRAM
- Up to 71 User I/Os

Reprogrammable Flash Technology

- 130-nm, 7-Layer Metal, Flash-Based CMOS Process
- Live-at-Power-Up (LAPU) Level 0 Support
- Single-Chip Solution
- Retains Programmed Design When Powered Off
- 250 MHz (1.5 V systems) and 160 MHz (1.2 V systems) System Performance

In-System Programming (ISP) and Security

- Secure ISP Using On-Chip 128-Bit Advanced Encryption Standard (AES) Decryption via JTAG (IEEE 1532-compliant)
- FlashLock[®] to Secure FPGA Contents
- 1.2 V Programming

High-Performance Routing Hierarchy

- Segmented, Hierarchical Routing and Clock Structure

Advanced I/Os

- 1.2 V, 1.5 V, 1.8 V, 2.5 V, and 3.3 V Mixed-Voltage Operation
- Bank-Selectable I/O Voltages—up to 4 Banks per Chip
- Single-Ended I/O Standards: LVTTTL, LVCMOS 3.3 V / 2.5 V / 1.8 V / 1.5 V / 1.2 V
- Wide Range Power Supply Voltage Support per JESD8-B, Allowing I/Os to Operate from 2.7 V to 3.6 V
- Wide Range Power Supply Voltage Support per JESD8-12, Allowing I/Os to Operate from 1.14 V to 1.575 V
- I/O Registers on Input, Output, and Enable Paths
- Selectable Schmitt Trigger Inputs
- Hot-Swappable and Cold-Sparing I/Os
- Programmable Output Slew Rate and Drive Strength
- Weak Pull-Up/-Down
- IEEE 1149.1 (JTAG) Boundary Scan Test
- Pin-Compatible Packages across the IGLOO[®] Family

Clock Conditioning Circuit (CCC) and PLL[†]

- Up to Six CCC Blocks, One with an Integrated PLL
- Configurable Phase Shift, Multiply/Divide, Delay Capabilities, and External Feedback
- Wide Input Frequency Range (1.5 MHz up to 250 MHz)

Embedded Memory

- 1 kbit of FlashROM User Nonvolatile Memory
- SRAMs and FIFOs with Variable-Aspect-Ratio 4,608-Bit RAM Blocks (x1, x2, x4, x9, and x18 organizations)[†]
- True Dual-Port SRAM (except x 18 organization)[†]

Enhanced Commercial Temperature Range

- -20°C to +70°C

Table 1 • IGLOO nano Devices

IGLOO nano Devices	AGLN010	AGLN015	AGLN020		AGLN060	AGLN125	AGLN250
IGLOO nano-Z Devices ¹				AGLN030Z ¹	AGLN060Z	AGLN125Z	AGLN250Z
System Gates	10K	15K	20K	30K	60K	125K	250K
Typical Equivalent Macrocells	86	128	172	256	512	1,024	2,048
VersaTiles (D-flip-flops)	260	384	520	768	1,536	3,072	6,144
Flash*Freeze Mode (typical, μW)	2	4	4	5	10	16	24
RAM kbits (1,024 bits) ²	–	–	–	–	18	36	36
4,608-Bit Blocks ²	–	–	–	–	4	8	8
FlashROM Bits	1 k	1 k	1 k	1 k	1 k	1 k	1 k
Secure (AES) ISP ²	–	–	–	–	Yes	Yes	Yes
Integrated PLL in CCCs ^{2,3}	–	–	–	–	1	1	1
VersaNet Globals	4	4	4	6	18	18	18
I/O Banks	2	3	3	2	2	2	4
Maximum User I/Os (packaged device)	34	49	52	77	71	71	68
Maximum User I/Os (Known Good Die)	34	–	52	83	71	71	68
Package Pins							
UC/CS	UC36		UC81,	UC81, CS81	CS81	CS81	CS81
QFN	QN48	QN68	CS81	QN48, QN68			
VQFP			QN68	VQ100	VQ100	VQ100	VQ100

Notes:

1. AGLN030 is available in the Z feature grade only.
2. AGLN030 and smaller devices do not support this feature.
3. AGLN060, AGLN125, and AGLN250 in the CS81 package do not support PLLs.
4. For higher densities and support of additional features, refer to the IGLOO and IGLOOe handbooks.

[†] AGLN030 and smaller devices do not support this feature.

I/Os Per Package

IGLOO nano Devices	AGLN010	AGLN015	AGLN020		AGLN060	AGLN125	AGLN250
IGLOO nano-Z Devices				AGLN030Z ¹	AGLN060Z	AGLN125Z	AGLN250Z
Known Good Die	34	–	52	83	71	71	68
UC36	23						
QN48	34			34			
QN68		49	49	49			
UC81			52	66			
CS81			52	66	60	60	60
VQ100				77	71	71	68

Notes:

1. AGLN030 is available in the Z feature grade only.
2. When considering migrating your design to a lower- or higher-density device, refer to the [IGLOO Handbook](#) to ensure compliance with design and board migration requirements.
3. When the Flash*Freeze pin is used to directly enable Flash*Freeze mode and not used as a regular I/O, the number of single-ended user I/Os available is reduced by one.
4. "G" indicates RoHS-compliant packages. Refer to "[IGLOO nano Ordering Information](#)" on page III for the location of the "G" in the part number. For nano devices, the VQ100 package is offered in both leaded and RoHS-compliant versions. All other packages are RoHS-compliant only.

Packages	UC36	UC81	CS81	QN48	QN68	VQ100
Length x Width (mm\mm)	3 x 3	4 x 4	5 x 5	6 x 6	8 x 8	14 x 14
Nominal Area (mm ²)	9	16	36	36	64	196
Pitch (mm)	0.4	0.4	0.5	0.4	0.4	0.5
Height (mm)	0.80	0.80	0.80	0.90	0.90	1.20

IGLOO nano Device Status

IGLOO nano Devices	Status	IGLOO nano-Z Devices	Status
AGLN010	Production		
AGLN015	Production		
AGLN020	Production		
		AGLN030Z	Production
AGLN060	Advance	AGLN060Z	Advance
AGLN125	Advance	AGLN125Z	Advance
AGLN250	Production	AGLN250Z	Production

IGLOO nano Ordering Information

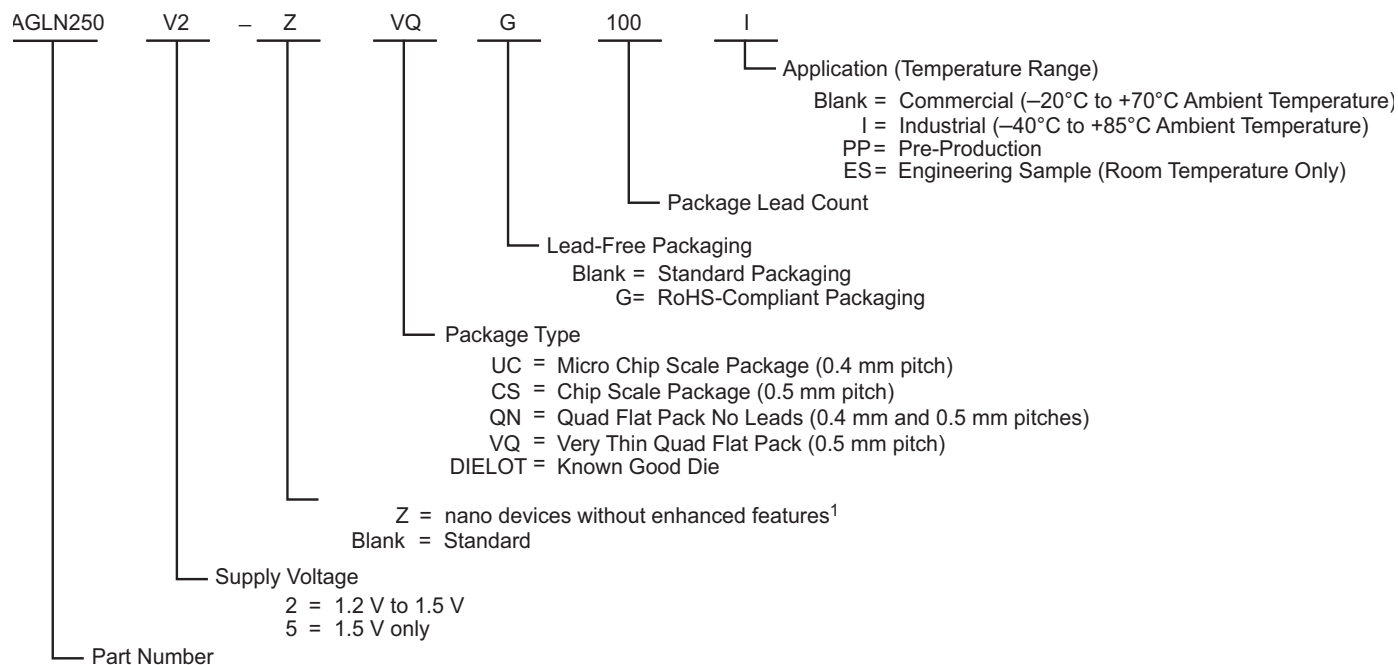

IGLOO nano Devices

AGLN010 = 10,000 System Gates
 AGLN015 = 15,000 System Gates
 AGLN020 = 20,000 System Gates
 AGLN030 = 30,000 System Gates
 AGLN060 = 60,000 System Gates
 AGLN125 = 125,000 System Gates
 AGLN250 = 250,000 System Gates

Notes:

- AGLN030 is available in the Z feature grade only.
- Z-feature grade devices AGLN060Z, AGLN125Z, and AGLN250Z do not support the enhanced nano features of Schmitt Trigger input, bus hold (hold previous I/O state in Flash*Freeze mode), cold-sparing, hot-swap I/O capability and 1.2 V programming. The AGLN030 Z feature grade does not support Schmitt trigger input, bus hold and 1.2 V programming. For the VQ100, CS81, UC81, QN68, and QN48 packages, the Z feature grade and the N part number are not marked on the device.
- Marking Information: IGLOO nano V2 devices do not have V2 marking, but IGLOO nano V5 devices are marked with a V5 designator.

Device Marking

Actel normally topside marks the full ordering part number on each device. There are some exceptions to this, such as some of the Z feature grade nano devices, the V2 designator for IGLOO devices, and packages where space is physically limited. Packages that have limited characters available are UC36, UC81, CS81, QN48, QN68, and QFN132. On these specific packages, a subset of the device marking will be used that includes the required legal information and as much of the part number as allowed by character limitation of the device. In this case, devices will have a truncated device marking and may exclude the applications markings, such as the I designator for Industrial Devices or the ES designator for Engineering Samples.

Figure 1 shows an example of device marking based on the AGL030V5-UCG81. The actual mark will vary by the device/package combination ordered.

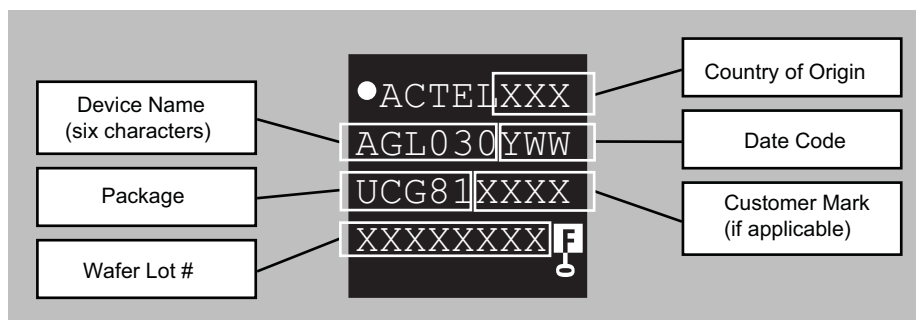

Figure 1 • Example of Device Marking for Small Form Factor Packages

IGLOO nano Product Available in the Z Feature Grade

IGLOO nano-Z Devices	AGLN030Z	AGLN060Z	AGLN125Z	AGLN250Z
Packages	QN48	–	–	–
	QN68	–	–	–
	UC81	–	–	–
	CS81	CS81	CS81	CS81
	VQ100	VQ100	VQ100	VQ100

Temperature Grade Offerings

Package	AGLN010	AGLN015	AGLN020		AGLN060	AGLN125	AGLN250
				AGLN030Z ¹	AGLN060Z	AGLN125Z	AGLN250Z
UC36	C, I	–	–	–	–	–	–
QN48	C, I	–	–	C, I	–	–	–
QN68	–	C, I	C, I	C, I	–	–	–
UC81	–	–	C, I	C, I	–	–	–
CS81	–	–	C, I	C, I	C, I	C, I	C, I
VQ100	–	–	–	C, I	C, I	C, I	C, I

Notes:

1. C = Extended Commercial temperature range: –20°C to 70°C ambient temperature.
2. I = Industrial temperature range: –40°C to 85°C ambient temperature.

Contact your local Actel representative for device availability: <http://www.actel.com/contact/default.aspx>.

Table of Contents

IGLOO nano Device Overview

General Description	1-1
---------------------------	-----

IGLOO nano DC and Switching Characteristics

General Specifications	2-1
Calculating Power Dissipation	2-7
User I/O Characteristics	2-15
VersaTile Characteristics	2-57
Global Resource Characteristics	2-63
Clock Conditioning Circuits	2-70
Embedded SRAM and FIFO Characteristics	2-73
Embedded FlashROM Characteristics	2-86
JTAG 1532 Characteristics	2-87
Actel Safety Critical, Life Support, and High-Reliability Applications Policy	2-88

Package Pin Assignments

36-Pin UC	3-1
81-Pin UC	3-3
81-Pin CS	3-6
48-Pin QFN	3-15
68-Pin QFN	3-18
100-Pin VQFP	3-22

Datasheet Information

List of Changes	4-1
Datasheet Categories	4-6
Actel Safety Critical, Life Support, and High-Reliability Applications Policy	4-6

1 – IGLOO nano Device Overview

General Description

The IGLOO family of flash FPGAs, based on a 130-nm flash process, offers the lowest power FPGA, a single-chip solution, small footprint packages, reprogrammability, and an abundance of advanced features.

The Flash*Freeze technology used in IGLOO nano devices enables entering and exiting an ultra-low power mode that consumes nanoPower while retaining SRAM and register data. Flash*Freeze technology simplifies power management through I/O and clock management with rapid recovery to operation mode.

The Low Power Active capability (static idle) allows for ultra-low power consumption while the IGLOO nano device is completely functional in the system. This allows the IGLOO nano device to control system power management based on external inputs (e.g., scanning for keyboard stimulus) while consuming minimal power.

Nonvolatile flash technology gives IGLOO nano devices the advantage of being a secure, low power, single-chip solution that is live at power-up (LAPU). The IGLOO nano device is reprogrammable and offers time-to-market benefits at an ASIC-level unit cost.

These features enable designers to create high-density systems using existing ASIC or FPGA design flows and tools.

IGLOO nano devices offer 1 kbit of on-chip, reprogrammable, nonvolatile FlashROM storage as well as clock conditioning circuitry based on an integrated phase-locked loop (PLL). The AGLN030 and smaller devices have no PLL or RAM support. IGLOO nano devices have up to 250 k system gates, supported with up to 36 kbits of true dual-port SRAM and up to 71 user I/Os.

IGLOO nano devices increase the breadth of the IGLOO product line by adding new features and packages for greater customer value in high volume consumer, portable, and battery-backed markets. Features such as smaller footprint packages designed with two-layer PCBs in mind, power consumption measured in nanoPower, Schmitt trigger, and bus hold (hold previous I/O state in Flash*Freeze mode) functionality make these devices ideal for deployment in applications that require high levels of flexibility and low cost.

Flash*Freeze Technology

The IGLOO nano device offers unique Flash*Freeze technology, allowing the device to enter and exit ultra-low power Flash*Freeze mode. IGLOO nano devices do not need additional components to turn off I/Os or clocks while retaining the design information, SRAM content, and registers. Flash*Freeze technology is combined with in-system programmability, which enables users to quickly and easily upgrade and update their designs in the final stages of manufacturing or in the field. The ability of IGLOO nano V2 devices to support a wide range of core voltage (1.2 V to 1.5 V) allows further reduction in power consumption, thus achieving the lowest total system power.

During Flash*Freeze mode, each I/O can be set to the following configurations: hold previous state, tristate, HIGH, or LOW.

The availability of low power modes, combined with reprogrammability, a single-chip and single-voltage solution, and small-footprint packages make IGLOO nano devices the best fit for portable electronics.

Flash Advantages

Low Power

Flash-based IGLOO nano devices exhibit power characteristics similar to those of an ASIC, making them an ideal choice for power-sensitive applications. IGLOO nano devices have only a very limited power-on current surge and no high-current transition period, both of which occur on many FPGAs.

IGLOO nano devices also have low dynamic power consumption to further maximize power savings; power is reduced even further by the use of a 1.2 V core voltage.

Low dynamic power consumption, combined with low static power consumption and Flash*Freeze technology, gives the IGLOO nano device the lowest total system power offered by any FPGA.

Security

Nonvolatile, flash-based IGLOO nano devices do not require a boot PROM, so there is no vulnerable external bitstream that can be easily copied. IGLOO nano devices incorporate FlashLock, which provides a unique combination of reprogrammability and design security without external overhead, advantages that only an FPGA with nonvolatile flash programming can offer.

IGLOO nano devices utilize a 128-bit flash-based lock and a separate AES key to secure programmed intellectual property and configuration data. In addition, all FlashROM data in IGLOO nano devices can be encrypted prior to loading, using the industry-leading AES-128 (FIPS192) bit block cipher encryption standard. AES was adopted by the National Institute of Standards and Technology (NIST) in 2000 and replaces the 1977 DES standard. IGLOO nano devices have a built-in AES decryption engine and a flash-based AES key that make them the most comprehensive programmable logic device security solution available today. IGLOO nano devices with AES-based security allow for secure, remote field updates over public networks such as the Internet, and ensure that valuable IP remains out of the hands of system overbuilders, system cloners, and IP thieves. The contents of a programmed IGLOO nano device cannot be read back, although secure design verification is possible.

Security, built into the FPGA fabric, is an inherent component of IGLOO nano devices. The flash cells are located beneath seven metal layers, and many device design and layout techniques have been used to make invasive attacks extremely difficult. IGLOO nano devices, with FlashLock and AES security, are unique in being highly resistant to both invasive and noninvasive attacks. Your valuable IP is protected and secure, making remote ISP possible. An IGLOO nano device provides the most impenetrable security for programmable logic designs.

Single Chip

Flash-based FPGAs store their configuration information in on-chip flash cells. Once programmed, the configuration data is an inherent part of the FPGA structure, and no external configuration data needs to be loaded at system power-up (unlike SRAM-based FPGAs). Therefore, flash-based IGLOO nano FPGAs do not require system configuration components such as EEPROMs or microcontrollers to load device configuration data. This reduces bill-of-materials costs and PCB area, and increases security and system reliability.

Live at Power-Up

Actel flash-based IGLOO nano devices support Level 0 of the LAPU classification standard. This feature helps in system component initialization, execution of critical tasks before the processor wakes up, setup and configuration of memory blocks, clock generation, and bus activity management. The LAPU feature of flash-based IGLOO nano devices greatly simplifies total system design and reduces total system cost, often eliminating the need for CPLDs and clock generation PLLs. In addition, glitches and brownouts in system power will not corrupt the IGLOO nano device's flash configuration, and unlike SRAM-based FPGAs, the device will not have to be reloaded when system power is restored. This enables the reduction or complete removal of the configuration PROM, expensive voltage monitor, brownout detection, and clock generator devices from the PCB design. Flash-based IGLOO nano devices simplify total system design and reduce cost and design risk while increasing system reliability and improving system initialization time.

IGLOO nano flash FPGAs enable the user to quickly enter and exit Flash*Freeze mode. This is done almost instantly (within 1 μ s) and the device retains configuration and data in registers and RAM. Unlike SRAM-based FPGAs, the device does not need to reload configuration and design state from external memory components; instead it retains all necessary information to resume operation immediately.

Reduced Cost of Ownership

Advantages to the designer extend beyond low unit cost, performance, and ease of use. Unlike SRAM-based FPGAs, flash-based IGLOO nano devices allow all functionality to be live at power-up; no external boot PROM is required. On-board security mechanisms prevent access to all the programming information and enable secure remote updates of the FPGA logic. Designers can perform secure remote in-system reprogramming to support future design iterations and field upgrades with confidence that

valuable intellectual property cannot be compromised or copied. Secure ISP can be performed using the industry-standard AES algorithm. The IGLOO nano device architecture mitigates the need for ASIC migration at higher user volumes. This makes IGLOO nano devices cost-effective ASIC replacement solutions, especially for applications in the consumer, networking/communications, computing, and avionics markets.

With a variety of devices under \$1, Actel IGLOO nano FPGAs enable cost-effective implementation of programmable logic and quick time to market.

Firm-Error Immunity

Firm errors occur most commonly when high-energy neutrons, generated in the upper atmosphere, strike a configuration cell of an SRAM FPGA. The energy of the collision can change the state of the configuration cell and thus change the logic, routing, or I/O behavior in an unpredictable way. These errors are impossible to prevent in SRAM FPGAs. The consequence of this type of error can be a complete system failure. Firm errors do not exist in the configuration memory of IGLOO nano flash-based FPGAs. Once it is programmed, the flash cell configuration element of IGLOO nano FPGAs cannot be altered by high-energy neutrons and is therefore immune to them. Recoverable (or soft) errors occur in the user data SRAM of all FPGA devices. These can easily be mitigated by using error detection and correction (EDAC) circuitry built into the FPGA fabric.

Advanced Flash Technology

The IGLOO nano device offers many benefits, including nonvolatility and reprogrammability, through an advanced flash-based, 130-nm LVCMOS process with seven layers of metal. Standard CMOS design techniques are used to implement logic and control functions. The combination of fine granularity, enhanced flexible routing resources, and abundant flash switches allows for very high logic utilization without compromising device routability or performance. Logic functions within the device are interconnected through a four-level routing hierarchy.

IGLOO nano FPGAs utilize design and process techniques to minimize power consumption in all modes of operation.

Advanced Architecture

The proprietary IGLOO nano architecture provides granularity comparable to standard-cell ASICs. The IGLOO nano device consists of five distinct and programmable architectural features (Figure 1-3 on page 1-5 to Figure 1-4 on page 1-5):

- Flash*Freeze technology
- FPGA VersaTiles
- Dedicated FlashROM
- Dedicated SRAM/FIFO memory†
- Extensive CCCs and PLLs†
- Advanced I/O structure

The FPGA core consists of a sea of VersaTiles. Each VersaTile can be configured as a three-input logic function, a D-flip-flop (with or without enable), or a latch by programming the appropriate flash switch interconnections. The versatility of the IGLOO nano core tile as either a three-input lookup table (LUT) equivalent or a D-flip-flop/latch with enable allows for efficient use of the FPGA fabric. The VersaTile capability is unique to the Actel ProASIC® family of third-generation-architecture flash FPGAs. VersaTiles are connected with any of the four levels of routing hierarchy. Flash switches are distributed throughout the device to provide nonvolatile, reconfigurable interconnect programming. Maximum core utilization is possible for virtually any design.

In addition, extensive on-chip programming circuitry enables rapid, single-voltage (3.3 V) programming of IGLOO nano devices via an IEEE 1532 JTAG interface.

† The AGLN030 and smaller devices do not support PLL or SRAM.

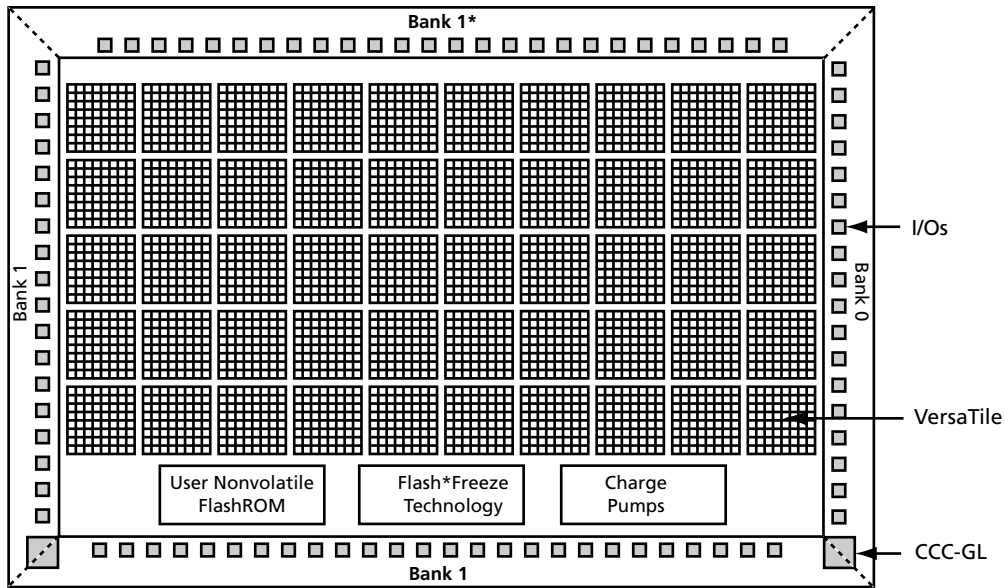

Note: *Bank 0 for the AGLN030 device

Figure 1-1 • IGLOO Device Architecture Overview with Two I/O Banks and No RAM (AGLN010 and AGLN030)

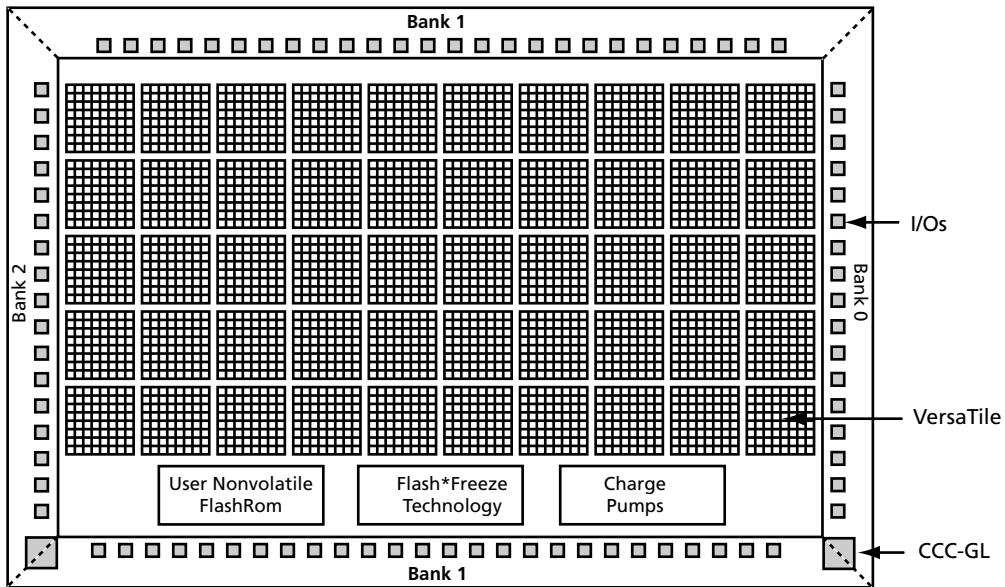

Figure 1-2 • IGLOO Device Architecture Overview with Three I/O Banks and No RAM (AGLN015 and AGLN020)

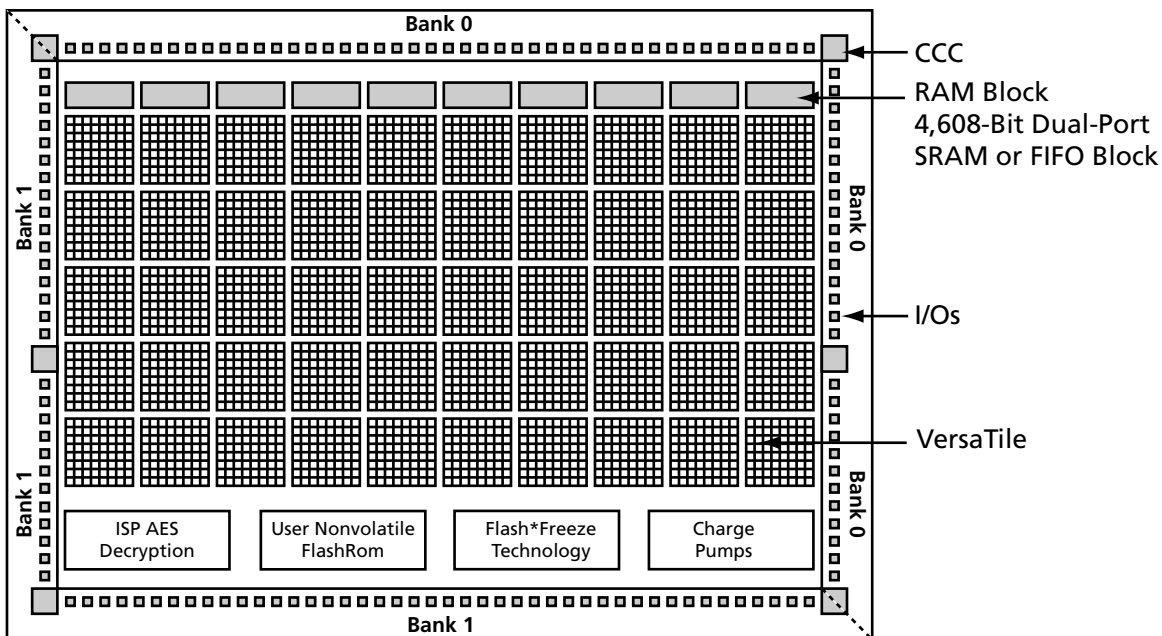

Figure 1-3 • IGLOO Device Architecture Overview with Two I/O Banks (AGLN060, AGLN125)

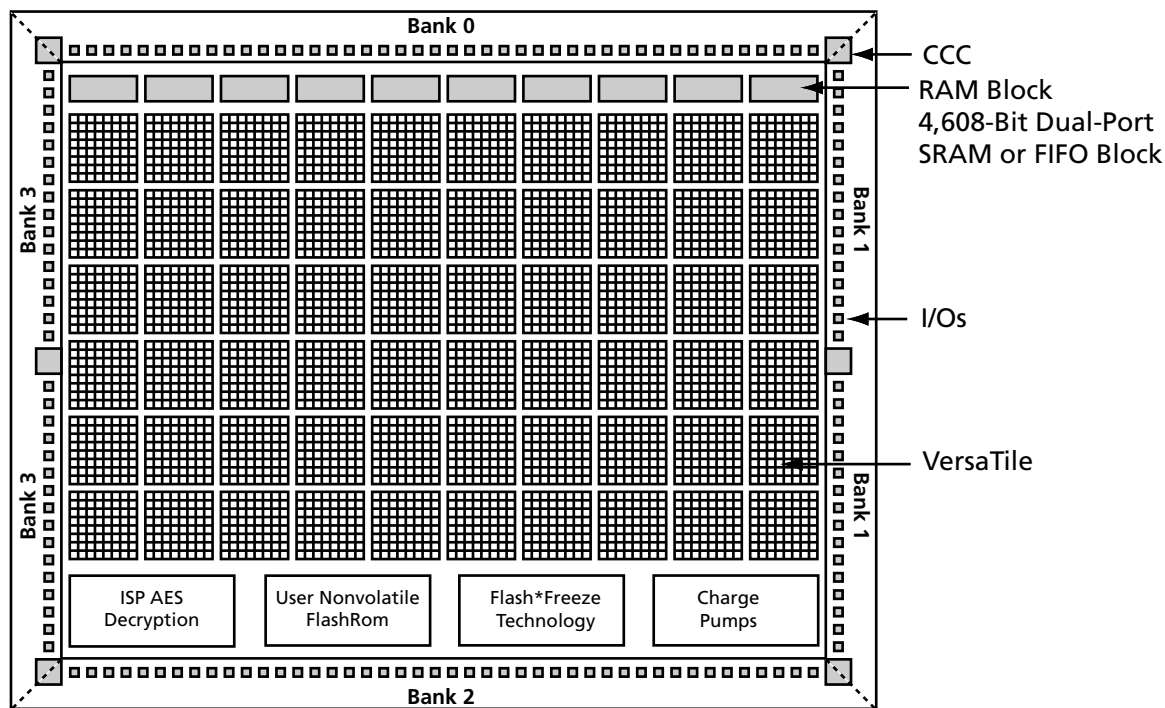

Figure 1-4 • IGLOO Device Architecture Overview with Four I/O Banks (AGLN250)

Flash*Freeze Technology

The IGL00 nano device has an ultra-low power static mode, called Flash*Freeze mode, which retains all SRAM and register information and can still quickly return to normal operation. Flash*Freeze technology enables the user to quickly (within 1 μ s) enter and exit Flash*Freeze mode by activating the Flash*Freeze pin while all power supplies are kept at their original values. I/Os, global I/Os, and clocks can still be driven and can be toggling without impact on power consumption, and the device retains all core registers, SRAM information, and I/O states. I/Os can be individually configured to either hold their previous state or be tristated during Flash*Freeze mode.

Alternatively, I/Os can be set to a specific state using weak pull-up or pull-down I/O attribute configuration. No power is consumed by the I/O banks, clocks, JTAG pins, or PLL, and the device consumes as little as 2 μ W in this mode.

Flash*Freeze technology allows the user to switch to Active mode on demand, thus simplifying the power management of the device.

The Flash*Freeze pin (active low) can be routed internally to the core to allow the user's logic to decide when it is safe to transition to this mode. Refer to [Figure 1-5](#) for an illustration of entering/exiting Flash*Freeze mode. It is also possible to use the Flash*Freeze pin as a regular I/O if Flash*Freeze mode usage is not planned.

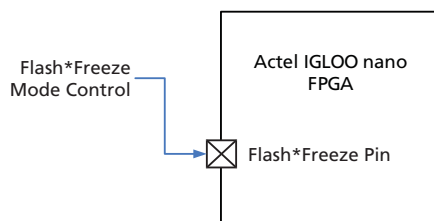

Figure 1-5 • IGL00 nano Flash*Freeze Mode

VersaTiles

The IGL00 nano core consists of VersaTiles, which have been enhanced beyond the ProASIC^{PLUS}® core tiles. The IGL00 nano VersaTile supports the following:

- All 3-input logic functions—LUT-3 equivalent
- Latch with clear or set
- D-flip-flop with clear or set
- Enable D-flip-flop with clear or set

Refer to [Figure 1-6](#) for VersaTile configurations.

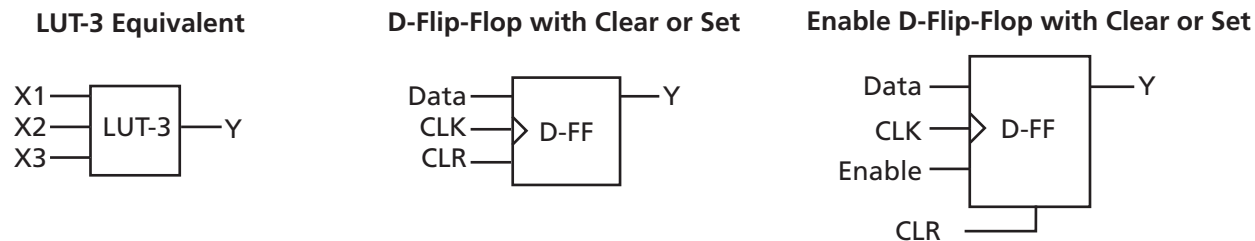

Figure 1-6 • VersaTile Configurations

User Nonvolatile FlashROM

Actel IGLOO nano devices have 1 kbit of on-chip, user-accessible, nonvolatile FlashROM. The FlashROM can be used in diverse system applications:

- Internet protocol addressing (wireless or fixed)
- System calibration settings
- Device serialization and/or inventory control
- Subscription-based business models (for example, set-top boxes)
- Secure key storage for secure communications algorithms
- Asset management/tracking
- Date stamping
- Version management

The FlashROM is written using the standard IGLOO nano IEEE 1532 JTAG programming interface. The core can be individually programmed (erased and written), and on-chip AES decryption can be used selectively to securely load data over public networks (except in the AGLN030 and smaller devices), as in security keys stored in the FlashROM for a user design.

The FlashROM can be programmed via the JTAG programming interface, and its contents can be read back either through the JTAG programming interface or via direct FPGA core addressing. Note that the FlashROM can only be programmed from the JTAG interface and cannot be programmed from the internal logic array.

The FlashROM is programmed as 8 banks of 128 bits; however, reading is performed on a byte-by-byte basis using a synchronous interface. A 7-bit address from the FPGA core defines which of the 8 banks and which of the 16 bytes within that bank are being read. The three most significant bits (MSBs) of the FlashROM address determine the bank, and the four least significant bits (LSBs) of the FlashROM address define the byte.

The Actel IGLOO nano development software solutions, Libero® Integrated Design Environment (IDE) and Designer, have extensive support for the FlashROM. One such feature is auto-generation of sequential programming files for applications requiring a unique serial number in each part. Another feature enables the inclusion of static data for system version control. Data for the FlashROM can be generated quickly and easily using Actel Libero IDE and Designer software tools. Comprehensive programming file support is also included to allow for easy programming of large numbers of parts with differing FlashROM contents.

SRAM and FIFO

IGLOO nano devices (except the AGLN030 and smaller devices) have embedded SRAM blocks along their north and south sides. Each variable-aspect-ratio SRAM block is 4,608 bits in size. Available memory configurations are 256×18, 512×9, 1k×4, 2k×2, and 4k×1 bits. The individual blocks have independent read and write ports that can be configured with different bit widths on each port. For example, data can be sent through a 4-bit port and read as a single bitstream. The embedded SRAM blocks can be initialized via the device JTAG port (ROM emulation mode) using the UJTAG macro (except in the AGLN030 and smaller devices).

In addition, every SRAM block has an embedded FIFO control unit. The control unit allows the SRAM block to be configured as a synchronous FIFO without using additional core VersaTiles. The FIFO width and depth are programmable. The FIFO also features programmable Almost Empty (AEMPTY) and Almost Full (AFULL) flags in addition to the normal Empty and Full flags. The embedded FIFO control unit contains the counters necessary for generation of the read and write address pointers. The embedded SRAM/FIFO blocks can be cascaded to create larger configurations.

PLL and CCC

Higher density IGLOO nano devices using either the two I/O bank or four I/O bank architectures provide designers with very flexible clock conditioning capabilities. AGLN060, AGLN125, and AGLN250 contain six CCCs. One CCC (center west side) has a PLL. The AGLN030 and smaller devices use different CCCs in their architecture (CCC-GL). These CCC-GLs contain a global MUX but do not have any PLLs or programmable delays.

For devices using the six CCC block architecture, these are located at the four corners and the centers of the east and west sides. All six CCC blocks are usable; the four corner CCCs and the east CCC allow simple clock delay operations as well as clock spine access.

The inputs of the six CCC blocks are accessible from the FPGA core or from dedicated connections to the CCC block, which are located near the CCC.

The CCC block has these key features:

- Wide input frequency range (f_{IN_CCC}) = 1.5 MHz up to 250 MHz
- Output frequency range (f_{OUT_CCC}) = 0.75 MHz up to 250 MHz
- 2 programmable delay types for clock skew minimization
- Clock frequency synthesis (for PLL only)

Additional CCC specifications:

- Internal phase shift = 0°, 90°, 180°, and 270°. Output phase shift depends on the output divider configuration (for PLL only).
- Output duty cycle = 50% ± 1.5% or better (for PLL only)
- Low output jitter: worst case < 2.5% × clock period peak-to-peak period jitter when single global network used (for PLL only)
- Maximum acquisition time is 300 μs (for PLL only)
- Exceptional tolerance to input period jitter—allowable input jitter is up to 1.5 ns (for PLL only)
- Four precise phases; maximum misalignment between adjacent phases of 40 ps × 250 MHz / f_{OUT_CCC} (for PLL only)

Global Clocking

IGLOO nano devices have extensive support for multiple clocking domains. In addition to the CCC and PLL support described above, there is a comprehensive global clock distribution network.

Each VersaTile input and output port has access to nine VersaNets: six chip (main) and three quadrant global networks. The VersaNets can be driven by the CCC or directly accessed from the core via multiplexers (MUXes). The VersaNets can be used to distribute low-skew clock signals or for rapid distribution of high-fanout nets.

I/Os with Advanced I/O Standards

IGLOO nano FPGAs feature a flexible I/O structure, supporting a range of voltages (1.2 V, 1.2 V wide range, 1.5 V, 1.8 V, 2.5 V, 3.0 V wide range, and 3.3 V).

The I/Os are organized into banks with two, three, or four banks per device. The configuration of these banks determines the I/O standards supported.

Each I/O module contains several input, output, and enable registers. These registers allow the implementation of various single-data-rate applications for all versions of nano devices and double-data-rate applications for the AGLN060, AGLN125, and AGLN250 devices.

IGLOO nano devices support LVTTTL and LVCMOS I/O standards, are hot-swappable, and support cold-sparing and Schmitt trigger.

Hot-swap (also called hot-plug, or hot-insertion) is the operation of hot-insertion or hot-removal of a card in a powered-up system.

Cold-sparing (also called cold-swap) refers to the ability of a device to leave system data undisturbed when the system is powered up, while the component itself is powered down, or when power supplies are floating.

Wide Range I/O Support

Actel nano devices support JEDEC-defined wide range I/O operation. IGLOO nano devices support both the JESD8-B specification, covering both 3 V and 3.3 V supplies, for an effective operating range of 2.7 V to 3.6 V, and JESD8-12 with its 1.2 V nominal, supporting an effective operating range of 1.14 V to 1.575 V.

Wider I/O range means designers can eliminate power supplies or power conditioning components from the board or move to less costly components with greater tolerances. Wide range eases I/O bank management and provides enhanced protection from system voltage spikes, while providing the flexibility to easily run custom voltage applications.

2 – IGLOO nano DC and Switching Characteristics

General Specifications

The Z feature grade does not support the enhanced nano features of Schmitt trigger input, Flash*Freeze bus hold (hold previous I/O state in Flash*Freeze mode), cold-sparing, and hot-swap I/O capability. Refer to "IGLOO nano Ordering Information" on page III for more information.

Operating Conditions

Stresses beyond those listed in [Table 2-1](#) may cause permanent damage to the device.

Exposure to absolute maximum rating conditions for extended periods may affect device reliability. Absolute Maximum Ratings are stress ratings only; functional operation of the device at these or any other conditions beyond those listed under the Recommended Operating Conditions specified in [Table 2-2](#) on [page 2-2](#) is not implied.

Table 2-1 • Absolute Maximum Ratings

Symbol	Parameter	Limits	Units
VCC	DC core supply voltage	-0.3 to 1.65	V
VJTAG	JTAG DC voltage	-0.3 to 3.75	V
VPUMP	Programming voltage	-0.3 to 3.75	V
VCCPLL	Analog power supply (PLL)	-0.3 to 1.65	V
VCCI	DC I/O buffer supply voltage	-0.3 to 3.75	V
VI ¹	I/O input voltage	-0.3 V to 3.6 V	V
T _{STG} ²	Storage temperature	-65 to +150	°C
T _J ²	Junction temperature	+125	°C

Notes:

1. The device should be operated within the limits specified by the datasheet. During transitions, the input signal may undershoot or overshoot according to the limits shown in [Table 2-4](#) on [page 2-3](#).
2. For flash programming and retention maximum limits, refer to [Table 2-3](#) on [page 2-2](#), and for recommended operating limits, refer to [Table 2-2](#) on [page 2-2](#).

Table 2-2 • Recommended Operating Conditions¹

Symbol	Parameter		Extended Commercial	Industrial	Units
T _A	Ambient temperature		-20 to +70 ²	-40 to +85 ²	°C
T _J	Junction temperature		-20 to +85 ²	-40 to +100 ²	°C
VCC	1.5 V DC core supply voltage ³		1.425 to 1.575	1.425 to 1.575	V
	1.2 V–1.5 V wide range core voltage ^{4,5}		1.14 to 1.575	1.14 to 1.575	V
VJTAG	JTAG DC voltage		1.4 to 3.6	1.4 to 3.6	V
VPUMP ⁶	Programming voltage	Programming mode	3.15 to 3.45	3.15 to 3.45	V
		Operation	0 to 3.6	0 to 3.6	V
VCCPLL ⁷	Analog power supply (PLL)	1.5 V DC core supply voltage ³	1.425 to 1.575	1.425 to 1.575	V
		1.2 V–1.5 V wide range core supply voltage ⁴	1.14 to 1.575	1.14 to 1.575	V
VCCI and VMV ^{8,9}	1.2 V DC supply voltage ⁴		1.14 to 1.26	1.14 to 1.26	V
	1.2 V DC wide range supply voltage ⁴		1.14 to 1.575	1.14 to 1.575	V
	1.5 V DC supply voltage		1.425 to 1.575	1.425 to 1.575	V
	1.8 V DC supply voltage		1.7 to 1.9	1.7 to 1.9	V
	2.5 V DC supply voltage		2.3 to 2.7	2.3 to 2.7	V
	3.3 V DC supply voltage		3.0 to 3.6	3.0 to 3.6	V
	3.3 V DC wide range supply voltage ¹⁰		2.7 to 3.6	2.7 to 3.6	V

Notes:

- All parameters representing voltages are measured with respect to GND unless otherwise specified.
- To ensure targeted reliability standards are met across ambient and junction operating temperatures, Actel recommends that the user follow best design practices using Actel's timing and power simulation tools.
- For IGLOO[®] nano V5 devices
- For IGLOO nano V2 devices only, operating at $V_{CCI} \geq V_{CC}$
- IGLOO nano V5 devices can be programmed with the VCC core voltage at 1.5 V only. IGLOO nano V2 devices can be programmed with the VCC core voltage at 1.2 V (with FlashPro4 only) or 1.5 V. If you are using FlashPro3 and want to do in-system programming using 1.2 V, please contact the factory.
- V_{PUMP} can be left floating during operation (not programming mode).
- VCCPLL pins should be tied to V_{CC} pins. See the "Pin Descriptions and Packaging" chapter for further information.
- VMV pins must be connected to the corresponding V_{CCI} pins. See the Pin Descriptions chapter of the IGLOO nano FPGA Fabric User's Guide for further information.
- The ranges given here are for power supplies only. The recommended input voltage ranges specific to each I/O standard are given in Table 2-21 on page 2-19. VCCI should be at the same voltage within a given I/O bank.
- 3.3 V wide range is compliant to the JESD8-B specification and supports 3.0 V VCCI operation.

Table 2-3 • Flash Programming Limits – Retention, Storage, and Operating Temperature¹

Product Grade	Programming Cycles	Program Retention (biased/unbiased)	Maximum Storage Temperature T _{STG} (°C) ²	Maximum Operating Junction Temperature T _J (°C) ²
Commercial	500	20 years	110	100
Industrial	500	20 years	110	100

Notes:

- This is a stress rating only; functional operation at any condition other than those indicated is not implied.
- These limits apply for program/data retention only. Refer to Table 2-1 on page 2-1 and Table 2-2 for device operating conditions and absolute limits.

Table 2-4 • Overshoot and Undershoot Limits¹

VCCI	Average VCCI–GND Overshoot or Undershoot Duration as a Percentage of Clock Cycle ²	Maximum Overshoot/Undershoot ²
2.7 V or less	10%	1.4 V
	5%	1.49 V
3 V	10%	1.1 V
	5%	1.19 V
3.3 V	10%	0.79 V
	5%	0.88 V
3.6 V	10%	0.45 V
	5%	0.54 V

Notes:

1. Based on reliability requirements at 85°C.
2. The duration is allowed at one out of six clock cycles. If the overshoot/undershoot occurs at one out of two cycles, the maximum overshoot/undershoot has to be reduced by 0.15 V.

I/O Power-Up and Supply Voltage Thresholds for Power-On Reset (Commercial and Industrial)

Sophisticated power-up management circuitry is designed into every IGLOO nano device. These circuits ensure easy transition from the powered-off state to the powered-up state of the device. The many different supplies can power up in any sequence with minimized current spikes or surges. In addition, the I/O will be in a known state through the power-up sequence. The basic principle is shown in [Figure 2-1 on page 2-4](#).

There are five regions to consider during power-up.

IGLOO nano I/Os are activated only if ALL of the following three conditions are met:

1. VCC and VCCI are above the minimum specified trip points ([Figure 2-1](#) and [Figure 2-2 on page 2-5](#)).
2. $VCCI > VCC - 0.75 \text{ V}$ (typical)
3. Chip is in the operating mode.

VCCI Trip Point:

Ramping up (V5 devices): $0.6 \text{ V} < \text{trip_point_up} < 1.2 \text{ V}$

Ramping down (V5 devices): $0.5 \text{ V} < \text{trip_point_down} < 1.1 \text{ V}$

Ramping up (V2 devices): $0.75 \text{ V} < \text{trip_point_up} < 1.05 \text{ V}$

Ramping down (V2 devices): $0.65 \text{ V} < \text{trip_point_down} < 0.95 \text{ V}$

VCC Trip Point:

Ramping up (V5 devices): $0.6 \text{ V} < \text{trip_point_up} < 1.1 \text{ V}$

Ramping down (V5 devices): $0.5 \text{ V} < \text{trip_point_down} < 1.0 \text{ V}$

Ramping up (V2 devices): $0.65 \text{ V} < \text{trip_point_up} < 1.05 \text{ V}$

Ramping down (V2 devices): $0.55 \text{ V} < \text{trip_point_down} < 0.95 \text{ V}$

VCC and VCCI ramp-up trip points are about 100 mV higher than ramp-down trip points. This specifically built-in hysteresis prevents undesirable power-up oscillations and current surges. Note the following:

- During programming, I/Os become tristated and weakly pulled up to VCCI.
- JTAG supply, PLL power supplies, and charge pump VPUMP supply have no influence on I/O behavior.

PLL Behavior at Brownout Condition

Actel recommends using monotonic power supplies or voltage regulators to ensure proper power-up behavior. Power ramp-up should be monotonic at least until VCC and VCCPLX exceed brownout activation levels (see Figure 2-1 and Figure 2-2 on page 2-5 for more details).

When PLL power supply voltage and/or VCC levels drop below the VCC brownout levels ($0.75\text{ V} \pm 0.25\text{ V}$ for V5 devices, and $0.75\text{ V} \pm 0.2\text{ V}$ for V2 devices), the PLL output lock signal goes LOW and/or the output clock is lost. Refer to the "Brownout Voltage" section in the "Power-Up/Down Behavior of Low Power Flash Devices" chapter of the *IGLOO nano FPGA Fabric User's Guide* for information on clock and lock recovery.

Internal Power-Up Activation Sequence

1. Core
2. Input buffers
3. Output buffers, after 200 ns delay from input buffer activation

To make sure the transition from input buffers to output buffers is clean, ensure that there is no path longer than 100 ns from input buffer to output buffer in your design.

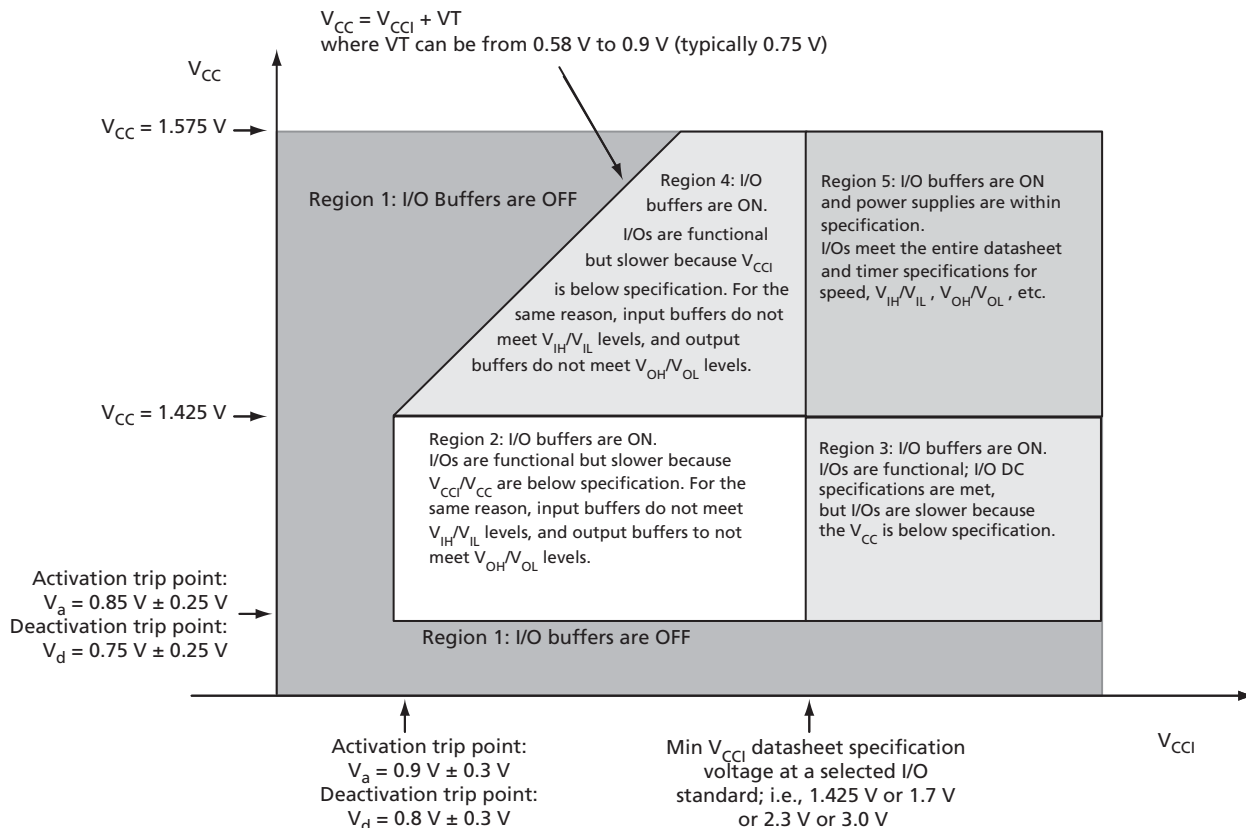

Figure 2-1 • V5 Devices – I/O State as a Function of VCCI and VCC Voltage Levels

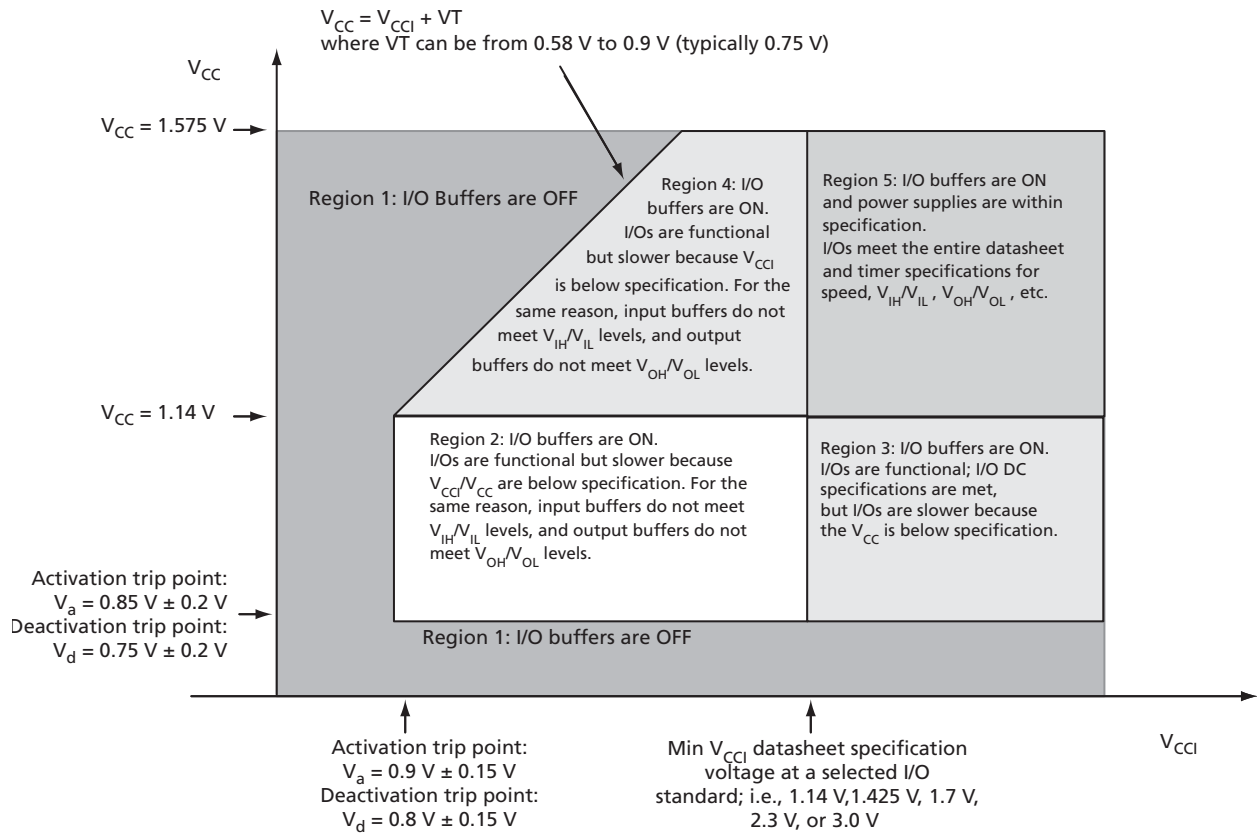

Figure 2-2 • V2 Devices – I/O State as a Function of VCCI and VCC Voltage Levels

Thermal Characteristics

Introduction

The temperature variable in the Actel Designer software refers to the junction temperature, not the ambient temperature. This is an important distinction because dynamic and static power consumption cause the chip junction temperature to be higher than the ambient temperature.

EQ 1 can be used to calculate junction temperature.

$$T_J = \text{Junction Temperature} = \Delta T + T_A$$

EQ 1

where:

T_A = Ambient temperature

ΔT = Temperature gradient between junction (silicon) and ambient $\Delta T = \theta_{ja} * P$

θ_{ja} = Junction-to-ambient of the package. θ_{ja} numbers are located in Figure 2-5.

P = Power dissipation

Package Thermal Characteristics

The device junction-to-case thermal resistivity is θ_{jc} and the junction-to-ambient air thermal resistivity is θ_{ja} . The thermal characteristics for θ_{ja} are shown for two air flow rates. The maximum operating junction temperature is 100°C. EQ 2 shows a sample calculation of the maximum operating power dissipation allowed for a 484-pin FBGA package at commercial temperature and in still air.

$$\text{Maximum Power Allowed} = \frac{\text{Max. junction temp. (}^\circ\text{C)} - \text{Max. ambient temp. (}^\circ\text{C)}}{\theta_{ja} (\text{}^\circ\text{C/W)}} = \frac{100^\circ\text{C} - 70^\circ\text{C}}{20.5^\circ\text{C/W}} = 1.46 \text{ W}$$

EQ 2

Table 2-5 • Package Thermal Resistivities

Package Type	Pin Count	θ_{jc}	θ_{ja}			Units
			Still Air	200 ft./min.	500 ft./min.	
Chip Scale Package (CSP)	36	TBD	TBD	TBD	TBD	C/W
	81	TBD	TBD	TBD	TBD	C/W
Quad Flat No Lead (QFN)	48	TBD	TBD	TBD	TBD	C/W
	68	TBD	TBD	TBD	TBD	C/W
	100	TBD	TBD	TBD	TBD	C/W
Very Thin Quad Flat Pack (VQFP)	100	10.0	35.3	29.4	27.1	C/W

Temperature and Voltage Derating Factors

Table 2-6 • Temperature and Voltage Derating Factors for Timing Delays (normalized to $T_J = 70^\circ\text{C}$, $V_{CC} = 1.425 \text{ V}$)
For IGLOO nano V2 or V5 Devices, 1.5 V DC Core Supply Voltage

Array Voltage VCC (V)	Junction Temperature ($^\circ\text{C}$)						
	-40°C	-20°C	0°C	25°C	70°C	85°C	100°C
1.425	0.947	0.956	0.965	0.978	1.000	1.009	1.013
1.5	0.875	0.883	0.892	0.904	0.925	0.932	0.937
1.575	0.821	0.829	0.837	0.848	0.868	0.875	0.879

Table 2-7 • Temperature and Voltage Derating Factors for Timing Delays (normalized to $T_J = 70^\circ\text{C}$, $V_{CC} = 1.14\text{ V}$)
 For IGLOO nano V2, 1.2 V DC Core Supply Voltage

Array Voltage VCC (V)	Junction Temperature ($^\circ\text{C}$)						
	-40°C	-20°C	0°C	25°C	70°C	85°C	100°C
1.14	0.968	0.974	0.979	0.991	1.000	1.006	1.009
1.2	0.863	0.868	0.873	0.884	0.892	0.898	0.901
1.26	0.792	0.797	0.801	0.811	0.819	0.824	0.827

Calculating Power Dissipation

Quiescent Supply Current

Note: Quiescent supply current (I_{DD}) calculation depends on multiple factors, including operating voltages (V_{CC} , V_{CCI} , and V_{JTAG}), operating temperature, system clock frequency, and power mode usage. Actel recommends using the Power Calculator and SmartPower software estimation tools to evaluate the projected static and active power based on the user design, power mode usage, operating voltage, and temperature.

Table 2-8 • Power Supply State per Mode

Modes/Power Supplies	Power Supply Configurations				
	VCC	VCCPLL	VCCI	VJTAG	VPUMP
Flash*Freeze	On	On	On	On	On/off/floating
Sleep	Off	Off	On	Off	Off
Shutdown	Off	Off	Off	Off	Off
No Flash*Freeze	On	On	On	On	On/off/floating

Note: Off: Power Supply level = 0 V

Table 2-9 • Quiescent Supply Current (I_{DD}) Characteristics, IGLOO nano Flash*Freeze Mode*

	Core Voltage	AGLN010	AGLN015	AGLN020	AGLN060	AGLN125	AGLN250	Units
Typical (25°C)	1.2 V	1.9	3.3	3.3	8	13	20	μA
	1.5 V	5.8	6	6	10	18	34	μA

Note: * I_{DD} includes VCC, VPUMP, VCCI, VJTAG, and VCCPLL currents.

Table 2-10 • Quiescent Supply Current (I_{DD}) Characteristics, IGLOO nano Sleep Mode*

	Core Voltage	AGLN010	AGLN015	AGLN020	AGLN060	AGLN125	AGLN250	Units
VCCI = 1.2 V (per bank) Typical (25°C)	1.2 V	1.7	1.7	1.7	1.7	1.7	1.7	μA
VCCI = 1.5 V (per bank) Typical (25°C)	1.2 V / 1.5 V	1.8	1.8	1.8	1.8	1.8	1.8	μA
VCCI = 1.8 V (per bank) Typical (25°C)	1.2 V / 1.5 V	1.9	1.9	1.9	1.9	1.9	1.9	μA
VCCI = 2.5 V (per bank) Typical (25°C)	1.2 V / 1.5 V	2.2	2.2	2.2	2.2	2.2	2.2	μA
VCCI = 3.3 V (per bank) Typical (25°C)	1.2 V / 1.5 V	2.5	2.5	2.5	2.5	2.5	2.5	μA

Note: $*I_{DD} = N_{BANKS} * I_{CCI}$

Table 2-11 • Quiescent Supply Current (I_{DD}) Characteristics, IGLOO nano Shutdown Mode

	Core Voltage	AGLN010	AGLN015	AGLN020	AGLN060	AGLN125	AGLN250	Units
Typical (25°C)	1.2 V / 1.5 V	0	0	0	0	0	0	μA

Table 2-12 • Quiescent Supply Current (I_{DD}), No IGLOO nano Flash*Freeze Mode¹

	Core Voltage	AGLN010	AGLN015	AGLN020	AGLN060	AGLN125	AGLN250	Units
I_{CCA} Current²								
Typical (25°C)	1.2 V	3.7	5	5	10	13	18	μA
	1.5 V	8	14	14	20	28	44	μA
I_{CCI} or I_{JTAG} Current								
VCCI / VJTAG = 1.2 V (per bank) Typical (25°C)	1.2 V	1.7	1.7	1.7	1.7	1.7	1.7	μA
VCCI / VJTAG = 1.5 V (per bank) Typical (25°C)	1.2 V / 1.5 V	1.8	1.8	1.8	1.8	1.8	1.8	μA
VCCI / VJTAG = 1.8 V (per bank) Typical (25°C)	1.2 V / 1.5 V	1.9	1.9	1.9	1.9	1.9	1.9	μA
VCCI / VJTAG = 2.5 V (per bank) Typical (25°C)	1.2 V / 1.5 V	2.2	2.2	2.2	2.2	2.2	2.2	μA
VCCI / VJTAG = 3.3 V (per bank) Typical (25°C)	1.2 V / 1.5 V	2.5	2.5	2.5	2.5	2.5	2.5	μA

Notes:

- $I_{DD} = N_{BANKS} * I_{CCI} + I_{CCA}$. JTAG counts as one bank when powered.
- Includes VCC, VCCPLL, and VPUMP currents.

Power per I/O Pin

Table 2-13 • Summary of I/O Input Buffer Power (per pin) – Default I/O Software Settings
Applicable to IGLOO nano I/O Banks

	VCCI (V)	Dynamic Power P _{AC9} (μW/MHz) ¹
Single-Ended		
3.3 V LVTTTL / 3.3 V LVCMOS	3.3	16.38
3.3 V LVTTTL / 3.3 V LVCMOS – Schmitt Trigger	3.3	18.89
3.3 V LVCMOS Wide Range ²	3.3	16.38
3.3 V LVCMOS Wide Range – Schmitt Trigger	3.3	18.89
2.5 V LVCMOS	2.5	4.71
2.5 V LVCMOS – Schmitt Trigger	2.5	6.13
1.8 V LVCMOS	1.8	1.64
1.8 V LVCMOS – Schmitt Trigger	1.8	1.79
1.5 V LVCMOS (JESD8-11)	1.5	0.97
1.5 V LVCMOS (JESD8-11) – Schmitt Trigger	1.5	0.96
1.2 V LVCMOS ³	1.2	0.57
1.2 V LVCMOS – Schmitt Trigger ³	1.2	0.52
1.2 V LVCMOS Wide Range ³	1.2	0.57
1.2 V LVCMOS Wide Range – Schmitt Trigger ³	1.2	0.52

Notes:

1. P_{AC9} is the total dynamic power measured on V_{CCI}.
2. All LVCMOS 3.3 V software macros support LVCMOS 3.3 V wide range as specified in the JESD8-B specification.
3. Applicable to IGLOO nano V2 devices operating at VCCI ≥ VCC.

Table 2-14 • Summary of I/O Output Buffer Power (per pin) – Default I/O Software Settings¹
Applicable to IGLOO nano I/O Banks

	C _{LOAD} (pF)	VCCI (V)	Dynamic Power P _{AC10} (μW/MHz) ²
Single-Ended			
3.3 V LVTTTL / 3.3 V LVCMOS	5	3.3	107.98
3.3 V LVCMOS Wide Range ³	5	3.3	107.98
2.5 V LVCMOS	5	2.5	61.24
1.8 V LVCMOS	5	1.8	31.28
1.5 V LVCMOS (JESD8-11)	5	1.5	21.50
1.2 V LVCMOS ⁴	5	1.2	15.22

Notes:

1. Dynamic power consumption is given for standard load and software default drive strength and output slew.
2. P_{AC10} is the total dynamic power measured on V_{CCI}.
3. All LVCMOS 3.3 V software macros support LVCMOS 3.3 V wide range as specified in the JESD8-B specification.
4. Applicable for IGLOO nano V2 devices operating at VCCI ≥ VCC.

Power Consumption of Various Internal Resources

Table 2-15 • Different Components Contributing to Dynamic Power Consumption in IGLOO nano Devices For IGLOO nano V2 or V5 Devices, 1.5 V Core Supply Voltage

Parameter	Definition	Device Specific Dynamic Power ($\mu\text{W}/\text{MHz}$)					
		AGLN250	AGLN125	AGLN060	AGLN020	AGLN015	AGLN010
P _{AC1}	Clock contribution of a Global Rib	11.03	11.03	9.3	9.3	9.3	9.3
P _{AC2}	Clock contribution of a Global Spine	1.58	0.81	0.81	0.41	0.41	0.41
P _{AC3}	Clock contribution of a VersaTile row	0.81					
P _{AC4}	Clock contribution of a VersaTile used as a sequential module	0.11					
P _{AC5}	First contribution of a VersaTile used as a sequential module	0.057					
P _{AC6}	Second contribution of a VersaTile used as a sequential module	0.207					
P _{AC7}	Contribution of a VersaTile used as a combinatorial module	0.17					
P _{AC8}	Average contribution of a routing net	0.7					
P _{AC9}	Contribution of an I/O input pin (standard-dependent)	See Table 2-13 on page 2-9.					
P _{AC10}	Contribution of an I/O output pin (standard-dependent)	See Table 2-14.					
P _{AC11}	Average contribution of a RAM block during a read operation	25.00			N/A		
P _{AC12}	Average contribution of a RAM block during a write operation	30.00			N/A		
P _{AC13}	Dynamic contribution for PLL	2.70			N/A		

Table 2-16 • Different Components Contributing to the Static Power Consumption in IGLOO nano Devices For IGLOO nano V2 or V5 Devices, 1.5 V Core Supply Voltage

Parameter	Definition	Device -Specific Static Power (mW)					
		AGLN250	AGLN125	AGLN060	AGLN020	AGLN015	AGLN010
P _{DC1}	Array static power in Active mode	See Table 2-12 on page 2-8					
P _{DC2}	Array static power in Static (Idle) mode	See Table 2-12 on page 2-8					
P _{DC3}	Array static power in Flash*Freeze mode	See Table 2-9 on page 2-7					
P _{DC4} ¹	Static PLL contribution	1.84			N/A		
P _{DC5}	Bank quiescent power (VCCI-dependent) ²	See Table 2-12 on page 2-8					

Notes:

1. Minimum contribution of the PLL when running at lowest frequency.
2. For a different output load, drive strength, or slew rate, Actel recommends using the Actel power spreadsheet calculator or the SmartPower tool in Actel Libero[®] Integrated Design Environment (IDE).

Table 2-17 • Different Components Contributing to Dynamic Power Consumption in IGLOO nano Devices For IGLOO nano V2 Devices, 1.2 V Core Supply Voltage

Parameter	Definition	Device-Specific Dynamic Power ($\mu\text{W}/\text{MHz}$)					
		AGLN250	AGLN125	AGLN060	AGLN020	AGLN015	AGLN010
P _{AC1}	Clock contribution of a Global Rib	7.07	7.07	5.96	5.96	5.96	5.96
P _{AC2}	Clock contribution of a Global Spine	1.01	0.52	0.52	0.26	0.26	0.26
P _{AC3}	Clock contribution of a VersaTile row	0.52					
P _{AC4}	Clock contribution of a VersaTile used as a sequential module	0.07					
P _{AC5}	First contribution of a VersaTile used as a sequential module	0.045					
P _{AC6}	Second contribution of a VersaTile used as a sequential module	0.186					
P _{AC7}	Contribution of a VersaTile used as a combinatorial module	0.11					
P _{AC8}	Average contribution of a routing net	0.45					
P _{AC9}	Contribution of an I/O input pin (standard-dependent)	See Table 2-13 on page 2-9					
P _{AC10}	Contribution of an I/O output pin (standard-dependent)	See Table 2-14 on page 2-9					
P _{AC11}	Average contribution of a RAM block during a read operation	25.00			N/A		
P _{AC12}	Average contribution of a RAM block during a write operation	30.00			N/A		
P _{AC13}	Dynamic contribution for PLL	2.10			N/A		

Table 2-18 • Different Components Contributing to the Static Power Consumption in IGLOO nano Devices For IGLOO nano V2 Devices, 1.2 V Core Supply Voltage

Parameter	Definition	Device-Specific Static Power (mW)					
		AGLN250	AGLN125	AGLN060	AGLN020	AGLN015	AGLN010
P _{DC1}	Array static power in Active mode	See Table 2-12 on page 2-8					
P _{DC2}	Array static power in Static (Idle) mode	See Table 2-12 on page 2-8					
P _{DC3}	Array static power in Flash*Freeze mode	See Table 2-9 on page 2-7					
P _{DC4} ¹	Static PLL contribution	0.90			N/A		
P _{DC5}	Bank quiescent power (VCCI-dependent) ²	See Table 2-12 on page 2-8					

Notes:

1. Minimum contribution of the PLL when running at lowest frequency.
2. For a different output load, drive strength, or slew rate, Actel recommends using the Actel power spreadsheet calculator or the SmartPower tool in Actel Libero IDE.

Power Calculation Methodology

This section describes a simplified method to estimate power consumption of an application. For more accurate and detailed power estimations, use the SmartPower tool in Actel Libero IDE software.

The power calculation methodology described below uses the following variables:

- The number of PLLs as well as the number and the frequency of each output clock generated
- The number of combinatorial and sequential cells used in the design
- The internal clock frequencies
- The number and the standard of I/O pins used in the design
- The number of RAM blocks used in the design
- Toggle rates of I/O pins as well as VersaTiles—guidelines are provided in [Table 2-19 on page 2-14](#).
- Enable rates of output buffers—guidelines are provided for typical applications in [Table 2-20 on page 2-14](#).
- Read rate and write rate to the memory—guidelines are provided for typical applications in [Table 2-20 on page 2-14](#). The calculation should be repeated for each clock domain defined in the design.

Methodology

Total Power Consumption— P_{TOTAL}

$$P_{TOTAL} = P_{STAT} + P_{DYN}$$

P_{STAT} is the total static power consumption.

P_{DYN} is the total dynamic power consumption.

Total Static Power Consumption— P_{STAT}

$$P_{STAT} = (P_{DC1} \text{ or } P_{DC2} \text{ or } P_{DC3}) + N_{BANKS} * P_{DC5}$$

N_{BANKS} is the number of I/O banks powered in the design.

Total Dynamic Power Consumption— P_{DYN}

$$P_{DYN} = P_{CLOCK} + P_{S-CELL} + P_{C-CELL} + P_{NET} + P_{INPUTS} + P_{OUTPUTS} + P_{MEMORY} + P_{PLL}$$

Global Clock Contribution— P_{CLOCK}

$$P_{CLOCK} = (P_{AC1} + N_{SPINE} * P_{AC2} + N_{ROW} * P_{AC3} + N_{S-CELL} * P_{AC4}) * F_{CLK}$$

N_{SPINE} is the number of global spines used in the user design—guidelines are provided in [Table 2-19 on page 2-14](#).

N_{ROW} is the number of VersaTile rows used in the design—guidelines are provided in [Table 2-19 on page 2-14](#).

F_{CLK} is the global clock signal frequency.

N_{S-CELL} is the number of VersaTiles used as sequential modules in the design.

P_{AC1} , P_{AC2} , P_{AC3} , and P_{AC4} are device-dependent.

Sequential Cells Contribution— P_{S-CELL}

$$P_{S-CELL} = N_{S-CELL} * (P_{AC5} + \alpha_1 / 2 * P_{AC6}) * F_{CLK}$$

N_{S-CELL} is the number of VersaTiles used as sequential modules in the design. When a multi-tile sequential cell is used, it should be accounted for as 1.

α_1 is the toggle rate of VersaTile outputs—guidelines are provided in [Table 2-19 on page 2-14](#).

F_{CLK} is the global clock signal frequency.

Combinatorial Cells Contribution— P_{C-CELL}

$$P_{C-CELL} = N_{C-CELL} * \alpha_1 / 2 * P_{AC7} * F_{CLK}$$

N_{C-CELL} is the number of VersaTiles used as combinatorial modules in the design.

α_1 is the toggle rate of VersaTile outputs—guidelines are provided in [Table 2-19](#) on page 2-14.

F_{CLK} is the global clock signal frequency.

Routing Net Contribution— P_{NET}

$$P_{NET} = (N_{S-CELL} + N_{C-CELL}) * \alpha_1 / 2 * P_{AC8} * F_{CLK}$$

N_{S-CELL} is the number of VersaTiles used as sequential modules in the design.

N_{C-CELL} is the number of VersaTiles used as combinatorial modules in the design.

α_1 is the toggle rate of VersaTile outputs—guidelines are provided in [Table 2-19](#) on page 2-14.

F_{CLK} is the global clock signal frequency.

I/O Input Buffer Contribution— P_{INPUTS}

$$P_{INPUTS} = N_{INPUTS} * \alpha_2 / 2 * P_{AC9} * F_{CLK}$$

N_{INPUTS} is the number of I/O input buffers used in the design.

α_2 is the I/O buffer toggle rate—guidelines are provided in [Table 2-19](#) on page 2-14.

F_{CLK} is the global clock signal frequency.

I/O Output Buffer Contribution— $P_{OUTPUTS}$

$$P_{OUTPUTS} = N_{OUTPUTS} * \alpha_2 / 2 * \beta_1 * P_{AC10} * F_{CLK}$$

$N_{OUTPUTS}$ is the number of I/O output buffers used in the design.

α_2 is the I/O buffer toggle rate—guidelines are provided in [Table 2-19](#) on page 2-14.

β_1 is the I/O buffer enable rate—guidelines are provided in [Table 2-20](#) on page 2-14.

F_{CLK} is the global clock signal frequency.

RAM Contribution— P_{MEMORY}

$$P_{MEMORY} = P_{AC11} * N_{BLOCKS} * F_{READ-CLOCK} * \beta_2 + P_{AC12} * N_{BLOCK} * F_{WRITE-CLOCK} * \beta_3$$

N_{BLOCKS} is the number of RAM blocks used in the design.

$F_{READ-CLOCK}$ is the memory read clock frequency.

β_2 is the RAM enable rate for read operations.

$F_{WRITE-CLOCK}$ is the memory write clock frequency.

β_3 is the RAM enable rate for write operations—guidelines are provided in [Table 2-20](#) on page 2-14.

PLL Contribution— P_{PLL}

$$P_{PLL} = P_{DC4} + P_{AC13} * F_{CLKOUT}$$

F_{CLKOUT} is the output clock frequency.¹

1. If a PLL is used to generate more than one output clock, include each output clock in the formula by adding its corresponding contribution ($P_{AC13} * F_{CLKOUT}$ product) to the total PLL contribution.

Guidelines

Toggle Rate Definition

A toggle rate defines the frequency of a net or logic element relative to a clock. It is a percentage. If the toggle rate of a net is 100%, this means that this net switches at half the clock frequency. Below are some examples:

- The average toggle rate of a shift register is 100% because all flip-flop outputs toggle at half of the clock frequency.
- The average toggle rate of an 8-bit counter is 25%:
 - Bit 0 (LSB) = 100%
 - Bit 1 = 50%
 - Bit 2 = 25%
 - ...
 - Bit 7 (MSB) = 0.78125%
 - Average toggle rate = $(100\% + 50\% + 25\% + 12.5\% + \dots + 0.78125\%) / 8$

Enable Rate Definition

Output enable rate is the average percentage of time during which tristate outputs are enabled. When nontristate output buffers are used, the enable rate should be 100%.

Table 2-19 • Toggle Rate Guidelines Recommended for Power Calculation

Component	Definition	Guideline
α_1	Toggle rate of VersaTile outputs	10%
α_2	I/O buffer toggle rate	10%

Table 2-20 • Enable Rate Guidelines Recommended for Power Calculation

Component	Definition	Guideline
β_1	I/O output buffer enable rate	100%
β_2	RAM enable rate for read operations	12.5%
β_3	RAM enable rate for write operations	12.5%

User I/O Characteristics

Timing Model

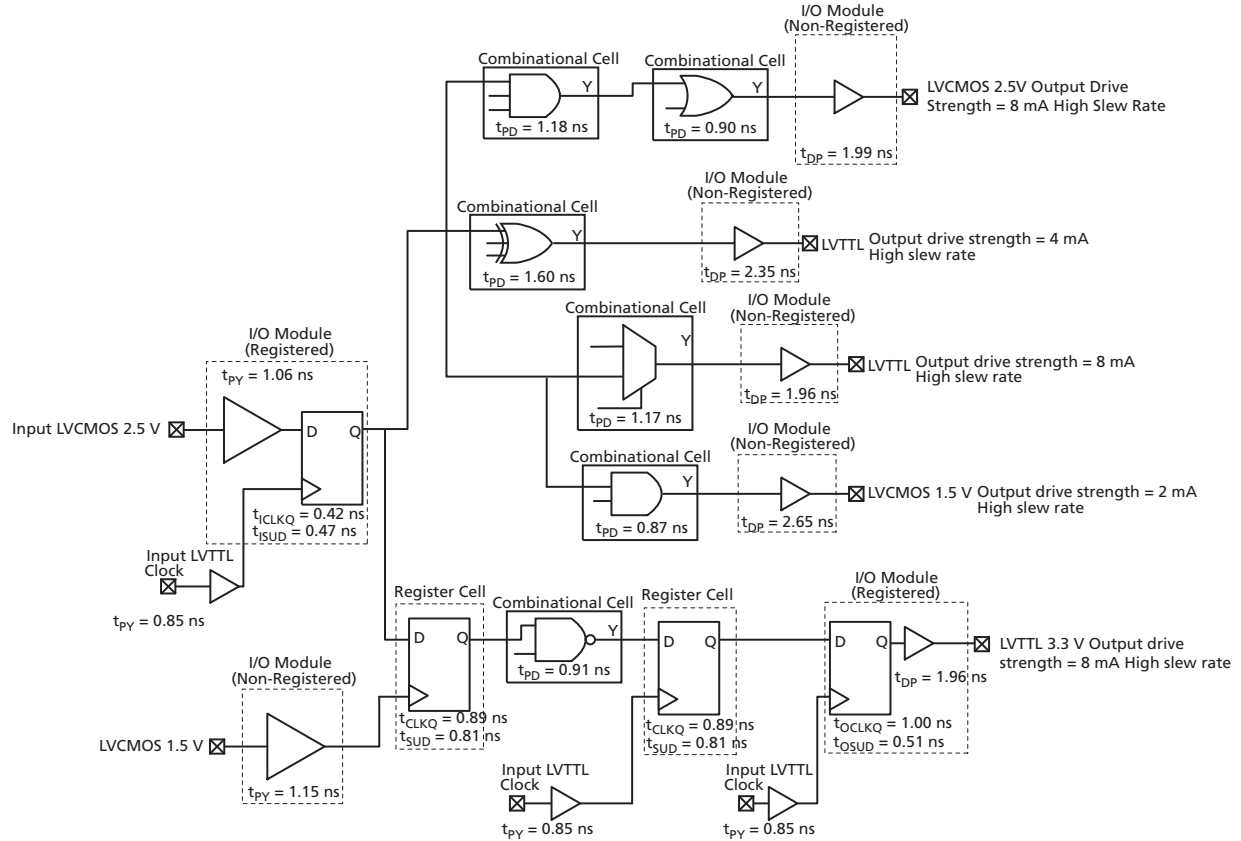

Figure 2-3 • Timing Model

Operating Conditions: STD Speed, Commercial Temperature Range ($T_J = 70^\circ\text{C}$), Worst-Case $V_{CC} = 1.425$ V, for DC 1.5 V Core Voltage, Applicable to V2 and V5 Devices

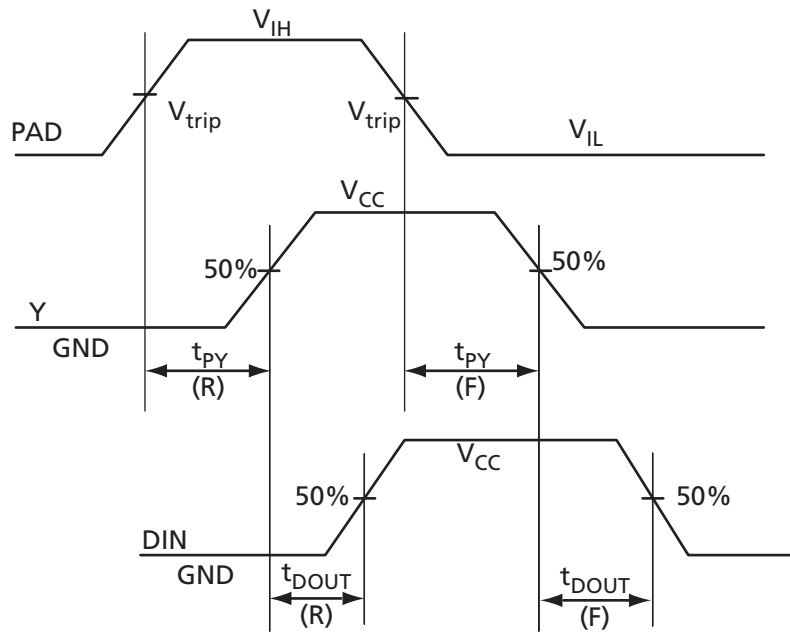
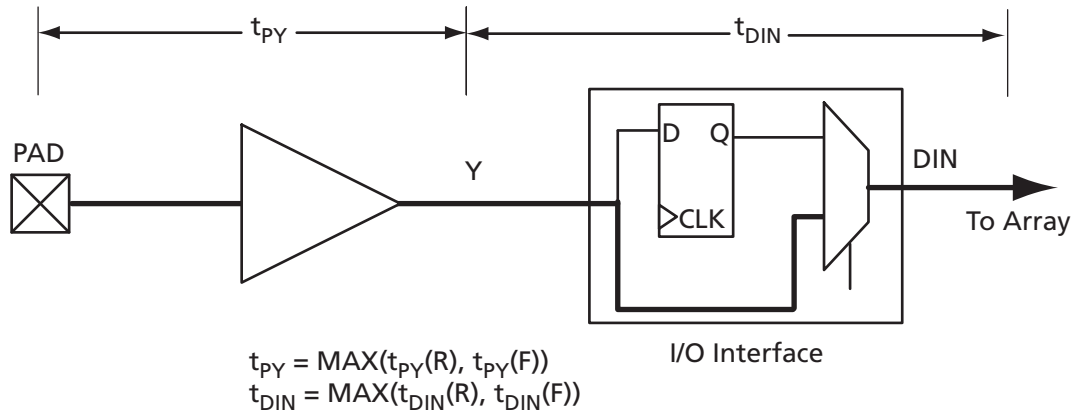

Figure 2-4 • Input Buffer Timing Model and Delays (example)

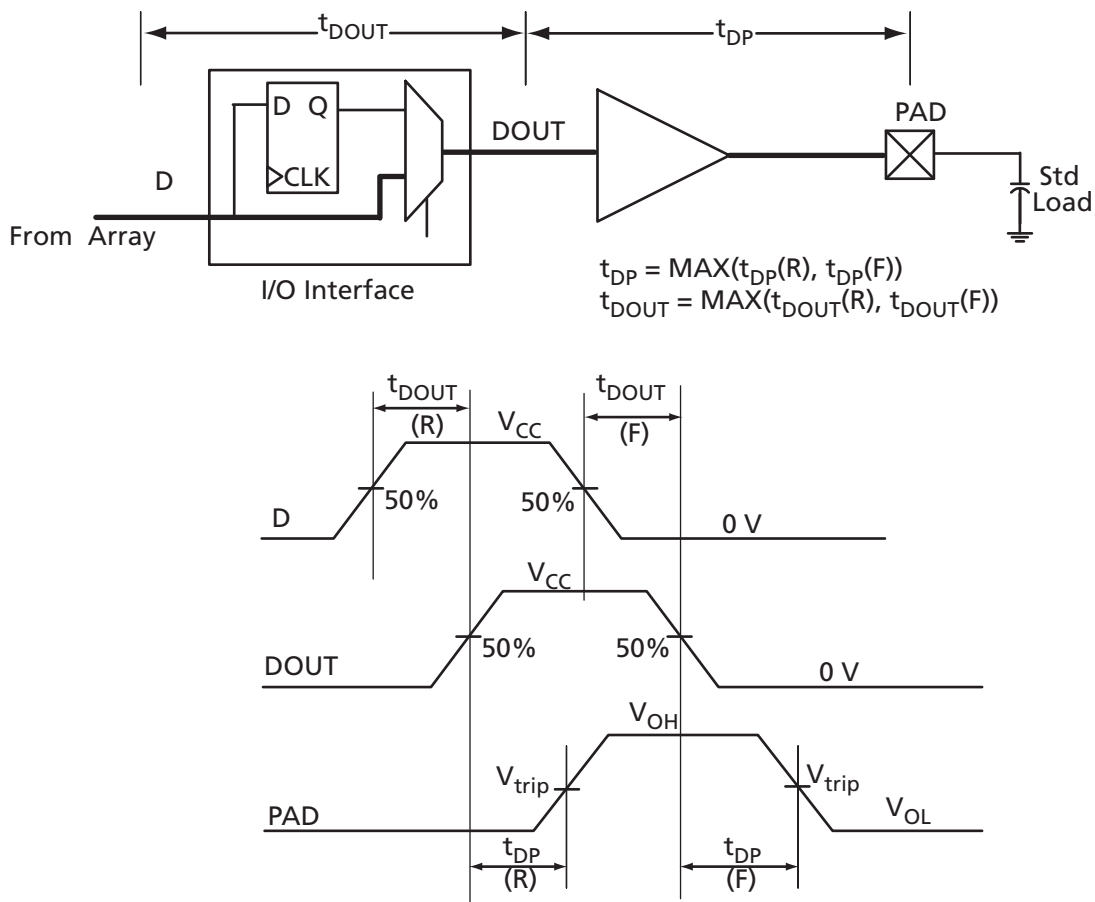

Figure 2-5 • Output Buffer Model and Delays (example)

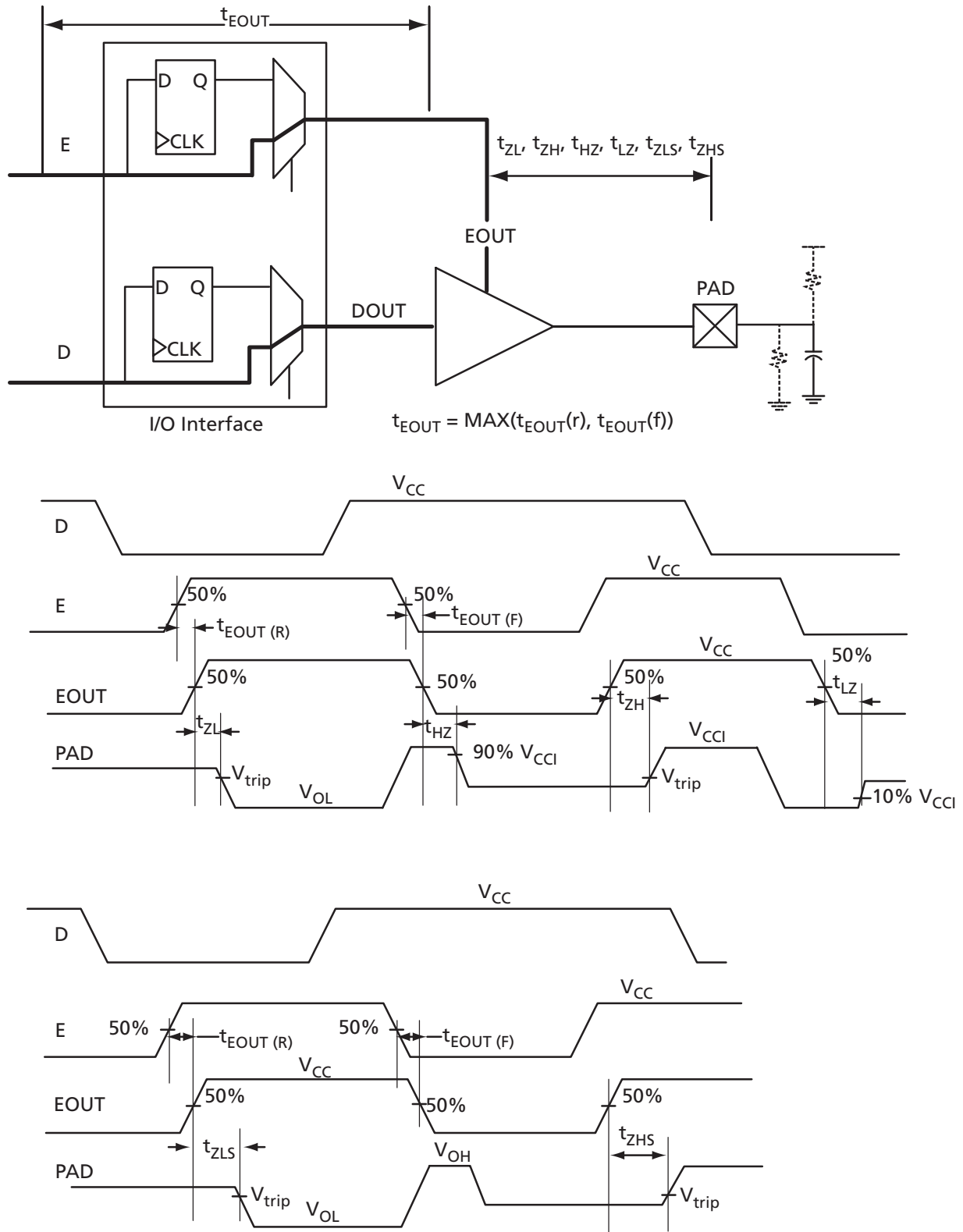

Figure 2-6 • Tristate Output Buffer Timing Model and Delays (example)

Overview of I/O Performance

Summary of I/O DC Input and Output Levels – Default I/O Software Settings

Table 2-21 • Summary of Maximum and Minimum DC Input and Output Levels
Applicable to Commercial and Industrial Conditions—Software Default Settings

I/O Standard	Drive Strength	Equivalent Software Default Drive Strength ²	Slew Rate	VIL		VIH		VOL	VOH	I _{OL} ¹	I _{OH} ¹
				Min. V	Max. V	Min. V	Max. V	Max. V	Min. V	mA	mA
3.3 V LVTTTL / 3.3 V LVCMOS	8 mA	8 mA	High	-0.3	0.8	2	3.6	0.4	2.4	8	8
3.3 V LVCMOS Wide Range ³	100 μ A	8 mA	High	-0.3	0.8	2	3.6	0.2	V _{CCI} - 0.2	100 μ A	100 μ A
2.5 V LVCMOS	8 mA	8 mA	High	-0.3	0.7	1.7	3.6	0.7	1.7	8	8
1.8 V LVCMOS	4 mA	4 mA	High	-0.3	0.35 * V _{CCI}	0.65 * V _{CCI}	3.6	0.45	V _{CCI} - 0.45	4	4
1.5 V LVCMOS	2 mA	2 mA	High	-0.3	0.35 * V _{CCI}	0.65 * V _{CCI}	3.6	0.25 * V _{CCI}	0.75 * V _{CCI}	2	2
1.2 V LVCMOS ⁴	1 mA	1 mA	High	-0.3	0.35 * V _{CCI}	0.65 * V _{CCI}	3.6	0.25 * V _{CCI}	0.75 * V _{CCI}	1	1
1.2 V LVCMOS Wide Range ^{4,5}	100 μ A	1 mA	High	-0.3	0.3 * V _{CCI}	0.7 * V _{CCI}	3.6	0.1	V _{CCI} - 0.1	100 μ A	100 μ A

Notes:

1. Currents are measured at 85°C junction temperature.
2. Note that 1.2 V LVCMOS and 3.3 V LVCMOS wide range is applicable to 100 μ A drive strength only. The configuration will not operate at the equivalent software default drive strength. These values are for normal ranges only.
3. All LVCMOS 3.3 V software macros support LVCMOS 3.3 V wide range, as specified in the JESD8-B specification.
4. Applicable to IGLOO nano V2 devices operating at V_{CCI} \geq V_{CC}.
5. All LVCMOS 1.2 V software macros support LVCMOS 1.2 V wide range, as specified in the JESD8-12 specification.

Table 2-22 • Summary of Maximum and Minimum DC Input Levels
Applicable to Commercial and Industrial Conditions

DC I/O Standards	Commercial ¹		Industrial ²	
	I _{IL} ³	I _{IH} ⁴	I _{IL} ³	I _{IH} ⁴
	μ A	μ A	μ A	μ A
3.3 V LVTTTL / 3.3 V LVCMOS	10	10	15	15
3.3 V LVCOMS Wide Range	10	10	15	15
2.5 V LVCMOS	10	10	15	15
1.8 V LVCMOS	10	10	15	15
1.5 V LVCMOS	10	10	15	15
1.2 V LVCMOS ⁵	10	10	15	15
1.2 V LVCMOS Wide Range ⁵	10	10	15	15

Notes:

1. Commercial range (-20°C < T_A < 70°C)
2. Industrial range (-40°C < T_A < 85°C)
3. I_{IH} is the input leakage current per I/O pin over recommended operating conditions, where V_{IH} < V_{IN} < V_{CCI}. Input current is larger when operating outside recommended ranges.
4. I_{IL} is the input leakage current per I/O pin over recommended operating conditions, where -0.3 V < V_{IN} < V_{IL}.
5. Applicable to IGLOO nano V2 devices operating at V_{CCI} \geq V_{CC}.

Summary of I/O Timing Characteristics – Default I/O Software Settings

Table 2-23 • Summary of AC Measuring Points

Standard	Measuring Trip Point (Vtrip)
3.3 V LVTTTL / 3.3 V LVCMOS	1.4 V
3.3 V LVCMOS Wide Range	1.4 V
2.5 V LVCMOS	1.2 V
1.8 V LVCMOS	0.90 V
1.5 V LVCMOS	0.75 V
1.2 V LVCMOS	0.60 V
1.2 V LVCMOS Wide Range	0.60 V

Table 2-24 • I/O AC Parameter Definitions

Parameter	Parameter Definition
t_{DP}	Data to Pad delay through the Output Buffer
t_{PY}	Pad to Data delay through the Input Buffer
t_{DOUT}	Data to Output Buffer delay through the I/O interface
t_{EOUT}	Enable to Output Buffer Tristate Control delay through the I/O interface
t_{DIN}	Input Buffer to Data delay through the I/O interface
t_{HZ}	Enable to Pad delay through the Output Buffer—HIGH to Z
t_{ZH}	Enable to Pad delay through the Output Buffer—Z to HIGH
t_{LZ}	Enable to Pad delay through the Output Buffer—LOW to Z
t_{ZL}	Enable to Pad delay through the Output Buffer—Z to LOW
t_{ZHS}	Enable to Pad delay through the Output Buffer with delayed enable—Z to HIGH
t_{ZLS}	Enable to Pad delay through the Output Buffer with delayed enable—Z to LOW

Applies to IGL00 nano at 1.5 V Core Operating Conditions

Table 2-25 • Summary of I/O Timing Characteristics—Software Default Settings
 STD Speed Grade, Commercial-Case Conditions: $T_J = 70^\circ\text{C}$, Worst-Case $V_{CC} = 1.425\text{ V}$,
 Worst-Case $V_{CCI} = 3.0\text{ V}$

I/O Standard	Drive Strength (mA)	Equivalent Software Default Drive Strength Option ¹	Slew Rate	Capacitive Load (pF)	t_{pOUT}	t_{DP}	t_{DIN}	t_{PY}	t_{PYS}	t_{EOUT}	t_{ZL}	t_{ZH}	t_{LZ}	t_{HZ}	Units
3.3 V LVTTTL / 3.3 V LVCMOS	8 mA	8 mA	High	5 pF	0.97	1.79	0.19	0.86	1.16	0.66	1.83	1.45	1.98	2.38	ns
3.3 V LVCMOS Wide Range ²	100 μA	8 mA	High	5 pF	0.97	2.56	0.19	1.20	1.66	0.66	2.57	2.02	2.82	3.31	ns
2.5 V LVCMOS	8 mA	8 mA	High	5 pF	0.97	1.81	0.19	1.10	1.24	0.66	1.85	1.63	1.97	2.26	ns
1.8 V LVCMOS	4 mA	4 mA	High	5 pF	0.97	2.08	0.19	1.03	1.44	0.66	2.12	1.95	1.99	2.19	ns
1.5 V LVCMOS	2 mA	2 mA	High	5 pF	0.97	2.39	0.19	1.19	1.52	0.66	2.44	2.24	2.02	2.15	ns

Notes:

1. Note that 3.3 V LVCMOS wide range is applicable to 100 μA drive strength only. The configuration will not operate at the equivalent default drive strength. These values are for normal ranges only.
2. All LVCMOS 3.3 V software macros support LVCMOS 3.3 V wide range, as specified in the JESD8-B specification.
3. For specific junction temperature and voltage supply levels, refer to [Table 2-6 on page 2-6](#) for derating values.

Applies to IGLOO nano at 1.2 V Core Operating Conditions

Table 2-26 • Summary of I/O Timing Characteristics—Software Default Settings
 STD Speed Grade, Commercial-Case Conditions: $T_J = 70^\circ\text{C}$, Worst-Case $V_{CC} = 1.14\text{ V}$,
 Worst-Case $V_{CCI} = 3.0\text{ V}$

I/O Standard	Drive Strength (mA)	Equiv. Software Default Drive Strength Option ¹	Slew Rate	Capacitive Load (pF)	t_{DOUT}	t_{DP}	t_{DIN}	t_{PY}	t_{PYS}	t_{EOUT}	t_{ZL}	t_{ZH}	t_{LZ}	t_{HZ}	Units
3.3 V LVTTTL / 3.3 V LVCMOS	8 mA	8 mA	High	5 pF	1.55	2.31	0.26	0.97	1.36	1.10	2.34	1.90	2.43	3.14	ns
3.3 V LVCMOS Wide Range ²	100 μA	8 mA	High	5 pF	1.55	3.25	0.26	1.31	1.91	1.10	3.25	2.61	3.38	4.27	ns
2.5 V LVCMOS	8 mA	8 mA	High	5 pF	1.55	2.30	0.26	1.21	1.39	1.10	2.33	2.04	2.41	2.99	ns
1.8 V LVCMOS	4 mA	4 mA	High	5 pF	1.55	2.49	0.26	1.13	1.59	1.10	2.53	2.34	2.42	2.81	ns
1.5 V LVCMOS	2 mA	2 mA	High	5 pF	1.55	2.78	0.26	1.27	1.77	1.10	2.82	2.62	2.44	2.74	ns
1.2 V LVCMOS	1 mA	1 mA	High	5 pF	1.55	3.50	0.26	1.56	2.27	1.10	3.37	3.10	2.55	2.66	ns
1.2 V LVCMOS Wide Range ³	100 μA	1 mA	High	5 pF	1.55	3.50	0.26	1.56	2.27	1.10	3.37	3.10	2.55	2.66	ns

Notes:

1. Note that 1.2 V LVCMOS and 3.3 V LVCMOS wide range are applicable to 100 μA drive strength only. The configuration will not operate at the equivalent default drive strength. These values are for normal ranges only.
2. All LVCMOS 3.3 V software macros support LVCMOS 3.3 V wide range, as specified in the JESD8-B specification.
3. All LVCMOS 1.2 V software macros support LVCMOS 1.2 V side range as specified in the JESD8-12 specification.
4. For specific junction temperature and voltage supply levels, refer to [Table 2-6 on page 2-6](#) for derating values.

Detailed I/O DC Characteristics

Table 2-27 • Input Capacitance

Symbol	Definition	Conditions	Min.	Max.	Units
C_{IN}	Input capacitance	$V_{IN} = 0, f = 1.0 \text{ MHz}$		8	pF
C_{INCLK}	Input capacitance on the clock pin	$V_{IN} = 0, f = 1.0 \text{ MHz}$		8	pF

Table 2-28 • I/O Output Buffer Maximum Resistances ¹

Standard	Drive Strength	$R_{PULL-DOWN}$ (Ω) ²	$R_{PULL-UP}$ (Ω) ³
3.3 V LVTTTL / 3.3V LVCMOS	2 mA	100	300
	4 mA	100	300
	6 mA	50	150
	8 mA	50	150
3.3 V LVCMOS Wide Range	100 μ A	Same as equivalent software default drive	
2.5 V LVCMOS	2 mA	100	200
	4 mA	100	200
	6 mA	50	100
	8 mA	50	100
1.8 V LVCMOS	2 mA	200	225
	4 mA	100	112
1.5 V LVCMOS	2 mA	200	224
1.2 V LVCMOS ⁴	1 mA	315	315
1.2 V LVCMOS Wide Range ⁴	100 μ A	315	315

Notes:

1. These maximum values are provided for informational reasons only. Minimum output buffer resistance values depend on V_{CCI} , drive strength selection, temperature, and process. For board design considerations and detailed output buffer resistances, use the corresponding IBIS models located on the Actel website: <http://www.actel.com/download/ibis/default.aspx>.
2. $R_{(PULL-DOWN-MAX)} = (V_{OLspec}) / I_{OLspec}$
3. $R_{(PULL-UP-MAX)} = (V_{CCImax} - V_{OHspec}) / I_{OHspec}$
4. Applicable to IGLOO nano V2 devices operating at $V_{CCI} \geq V_{CC}$.

Table 2-29 • I/O Weak Pull-Up/Pull-Down Resistances
Minimum and Maximum Weak Pull-Up/Pull-Down Resistance Values

VCCI	$R_{(WEAK\ PULL-UP)}^1 (\Omega)$		$R_{(WEAK\ PULL-DOWN)}^2 (\Omega)$	
	Min.	Max.	Min.	Max.
3.3 V	10 K	45 K	10 K	45 K
3.3 V (wide range I/Os)	10 K	45 K	10 K	45 K
2.5 V	11 K	55 K	12 K	74 K
1.8 V	18 K	70 K	17 K	110 K
1.5 V	19 K	90 K	19 K	140 K
1.2 V	25 K	110 K	25 K	150 K
1.2 V (wide range I/Os)	19 K	110 K	19 K	150 K

Notes:

- $R_{(WEAK\ PULL-UP-MAX)} = (VCCImax - VOHspec) / I_{(WEAK\ PULL-UP-MIN)}$
- $R_{(WEAK_PULLDOWN_MAX)} = (VOLspec) / I_{(WEAK_PULLDOWN_MIN)}$

Table 2-30 • I/O Short Currents I_{OSH}/I_{OSL}

	Drive Strength	I_{OSL} (mA)*	I_{OSH} (mA)*
3.3 V LVTTTL / 3.3 V LVCMOS	2 mA	25	27
	4 mA	25	27
	6 mA	51	54
	8 mA	51	54
3.3 V LVCMOS Wide Range	100 μ A	Same as equivalent software default drive	
2.5 V LVCMOS	2 mA	16	18
	4 mA	16	18
	6 mA	32	37
	8 mA	32	37
1.8 V LVCMOS	2 mA	9	11
	4 mA	17	22
1.5 V LVCMOS	2 mA	13	16
1.2 V LVCMOS	1 mA	10	13
1.2 V LVCMOS Wide Range	100 μ A	10	13

Note: * $T_J = 100^\circ\text{C}$

The length of time an I/O can withstand I_{OSH}/I_{OSL} events depends on the junction temperature. The reliability data below is based on a 3.3 V, 8 mA I/O setting, which is the worst case for this type of analysis.

For example, at 100°C, the short current condition would have to be sustained for more than six months to cause a reliability concern. The I/O design does not contain any short circuit protection, but such protection would only be needed in extremely prolonged stress conditions.

Table 2-31 • Duration of Short Circuit Event before Failure

Temperature	Time before Failure
-40°C	> 20 years
-20°C	> 20 years
0°C	> 20 years
25°C	> 20 years
70°C	5 years
85°C	2 years
100°C	6 months

**Table 2-32 • Schmitt Trigger Input Hysteresis
Hysteresis Voltage Value (Typ.) for Schmitt Mode Input Buffers**

Input Buffer Configuration	Hysteresis Value (typ.)
3.3 V LVTTTL / LVCMOS (Schmitt trigger mode)	240 mV
2.5 V LVCMOS (Schmitt trigger mode)	140 mV
1.8 V LVCMOS (Schmitt trigger mode)	80 mV
1.5 V LVCMOS (Schmitt trigger mode)	60 mV
1.2 V LVCMOS (Schmitt trigger mode)	40 mV

Table 2-33 • I/O Input Rise Time, Fall Time, and Related I/O Reliability

Input Buffer	Input Rise/Fall Time (min.)	Input Rise/Fall Time (max.)	Reliability
LVTTTL/LVCMOS (Schmitt trigger disabled)	No requirement	10 ns *	20 years (100°C)
LVTTTL/LVCMOS (Schmitt trigger enabled)	No requirement	No requirement, but input noise voltage cannot exceed Schmitt hysteresis.	20 years (100°C)

* The maximum input rise/fall time is related to the noise induced into the input buffer trace. If the noise is low, then the rise time and fall time of input buffers can be increased beyond the maximum value. The longer the rise/fall times, the more susceptible the input signal is to the board noise. Actel recommends signal integrity evaluation/characterization of the system to ensure that there is no excessive noise coupling into input signals.

Single-Ended I/O Characteristics

3.3 V LVTTTL / 3.3 V LVCMOS

Low-Voltage Transistor–Transistor Logic (LVTTTL) is a general purpose standard (EIA/JESD) for 3.3 V applications. It uses an LVTTTL input buffer and push-pull output buffer.

Table 2-34 • Minimum and Maximum DC Input and Output Levels

3.3 V LVTTTL / 3.3 V LVCMOS	VIL		VIH		VOL	VOH	IO _L	IO _H	I _{OSL}	I _{OSH}	I _{IL} ¹	I _{IH} ²
	Min. V	Max. V	Min. V	Max. V	Max. V	Min. V	mA	mA	Max. mA ³	Max. mA ³	μA ⁴	μA ⁴
2 mA	-0.3	0.8	2	3.6	0.4	2.4	2	2	25	27	10	10
4 mA	-0.3	0.8	2	3.6	0.4	2.4	4	4	25	27	10	10
6 mA	-0.3	0.8	2	3.6	0.4	2.4	6	6	51	54	10	10
8 mA	-0.3	0.8	2	3.6	0.4	2.4	8	8	51	54	10	10

Notes:

1. I_{IL} is the input leakage current per I/O pin over recommended operating conditions where $-0.3 < V_{IN} < V_{IL}$.
2. I_{IH} is the input leakage current per I/O pin over recommended operating conditions where $V_{IH} < V_{IN} < V_{CCI}$. Input current is larger when operating outside recommended ranges.
3. Currents are measured at high temperature (100°C junction temperature) and maximum voltage.
4. Currents are measured at 85°C junction temperature.
5. Software default selection highlighted in gray.

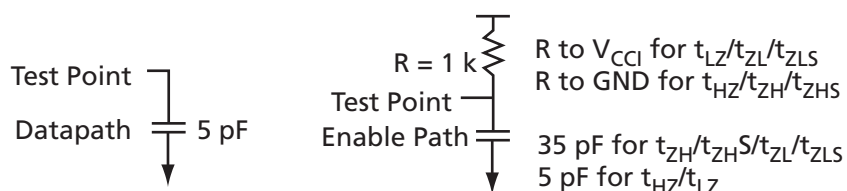

Figure 2-7 • AC Loading

Table 2-35 • 3.3 V LVTTTL/LVCMOS AC Waveforms, Measuring Points, and Capacitive Loads

Input LOW (V)	Input HIGH (V)	Measuring Point* (V)	C _{LOAD} (pF)
0	3.3	1.4	5

* Measuring point = V_{trip}. See Table 2-23 on page 2-20 for a complete table of trip points.

Timing Characteristics

Applies to 1.5 V DC Core Voltage

Table 2-36 • 3.3 V LVTTTL / 3.3 V LVCMOS Low Slew – Applies to 1.5 V DC Core Voltage

Commercial-Case Conditions: $T_J = 70^\circ\text{C}$, Worst-Case VCC = 1.425 V, Worst-Case VCCI = 3.0 V

Drive Strength	Speed Grade	t_{DOUT}	t_{DP}	t_{DIN}	t_{PY}	t_{PYS}	t_{EOUT}	t_{ZL}	t_{ZH}	t_{LZ}	t_{HZ}	Units
2 mA	STD	0.97	3.52	0.19	0.86	1.16	0.66	3.59	3.42	1.75	1.90	ns
4 mA	STD	0.97	3.52	0.19	0.86	1.16	0.66	3.59	3.42	1.75	1.90	ns
6 mA	STD	0.97	2.90	0.19	0.86	1.16	0.66	2.96	2.83	1.98	2.29	ns
8 mA	STD	0.97	2.90	0.19	0.86	1.16	0.66	2.96	2.83	1.98	2.29	ns

Note: For specific junction temperature and voltage supply levels, refer to [Table 2-6 on page 2-6](#) for derating values.

Table 2-37 • 3.3 V LVTTTL / 3.3 V LVCMOS High Slew – Applies to 1.5 V DC Core Voltage

Commercial-Case Conditions: $T_J = 70^\circ\text{C}$, Worst-Case VCC = 1.425 V, Worst-Case VCCI = 3.0 V

Drive Strength	Speed Grade	t_{DOUT}	t_{DP}	t_{DIN}	t_{PY}	t_{PYS}	t_{EOUT}	t_{ZL}	t_{ZH}	t_{LZ}	t_{HZ}	Units
2 mA	STD	0.97	2.16	0.19	0.86	1.16	0.66	2.20	1.80	1.75	1.99	ns
4 mA	STD	0.97	2.16	0.19	0.86	1.16	0.66	2.20	1.80	1.75	1.99	ns
6 mA	STD	0.97	1.79	0.19	0.86	1.16	0.66	1.83	1.45	1.98	2.38	ns
8 mA	STD	0.97	1.79	0.19	0.86	1.16	0.66	1.83	1.45	1.98	2.38	ns

Notes:

1. Software default selection highlighted in gray.
2. For specific junction temperature and voltage supply levels, refer to [Table 2-6 on page 2-6](#) for derating values.

Applies to 1.2 V DC Core Voltage
Table 2-38 • 3.3 V LVTTTL / 3.3 V LVCMOS Low Slew – Applies to 1.2 V DC Core Voltage

 Commercial-Case Conditions: $T_J = 70^\circ\text{C}$, Worst-Case VCC = 1.14 V, Worst-Case VCCI = 3.0 V

Drive Strength	Speed Grade	t_{DOUT}	t_{DP}	t_{DIN}	t_{PY}	t_{PYS}	t_{EOUT}	t_{zL}	t_{zH}	t_{LZ}	t_{HZ}	Units
2 mA	STD	1.55	4.09	0.26	0.97	1.36	1.10	4.16	3.91	2.19	2.64	ns
4 mA	STD	1.55	4.09	0.26	0.97	1.36	1.10	4.16	3.91	2.19	2.64	ns
6 mA	STD	1.55	3.45	0.26	0.97	1.36	1.10	3.51	3.32	2.43	3.03	ns
8 mA	STD	1.55	3.45	0.26	0.97	1.36	1.10	3.51	3.32	2.43	3.03	ns

Note: For specific junction temperature and voltage supply levels, refer to [Table 2-6 on page 2-6](#) for derating values.

Table 2-39 • 3.3 V LVTTTL / 3.3 V LVCMOS High Slew – Applies to 1.2 V DC Core Voltage

 Commercial-Case Conditions: $T_J = 70^\circ\text{C}$, Worst-Case VCC = 1.14 V, Worst-Case VCCI = 3.0 V

Drive Strength	Speed Grade	t_{DOUT}	t_{DP}	t_{DIN}	t_{PY}	t_{PYS}	t_{EOUT}	t_{zL}	t_{zH}	t_{LZ}	t_{HZ}	Units
2 mA	STD	1.55	2.68	0.26	0.97	1.36	1.10	2.72	2.26	2.19	2.74	ns
4 mA	STD	1.55	2.68	0.26	0.97	1.36	1.10	2.72	2.26	2.19	2.74	ns
6 mA	STD	1.55	2.31	0.26	0.97	1.36	1.10	2.34	1.90	2.43	3.14	ns
8 mA	STD	1.55	2.31	0.26	0.97	1.36	1.10	2.34	1.90	2.43	3.14	ns

Notes:

1. Software default selection highlighted in gray.
2. For specific junction temperature and voltage supply levels, refer to [Table 2-6 on page 2-6](#) for derating values.

3.3 V LVCMOS Wide Range

Table 2-40 • Minimum and Maximum DC Input and Output Levels for LVCMOS 3.3 V Wide Range

3.3 V LVCMOS Wide Range ¹	Equivalent Software Default Drive Strength Option ⁴	VIL		VIH		VOL	VOH	I _{OL}	I _{OH}	I _{IL} ²	I _{IH} ³
		Min. V	Max. V	Min. V	Max. V	Max. V	Min. V	μA	μA	μA ⁵	μA ⁵
100 μA	2 mA	-0.3	0.8	2	3.6	0.2	VCCI - 0.2	100	100	10	10
100 μA	4 mA	-0.3	0.8	2	3.6	0.2	VCCI - 0.2	100	100	10	10
100 μA	6 mA	-0.3	0.8	2	3.6	0.2	VCCI - 0.2	100	100	10	10
100 μA	8 mA	-0.3	0.8	2	3.6	0.2	VCCI - 0.2	100	100	10	10

Notes:

1. All LVCMOS 3.3 V software macros support LVCMOS 3.3 V Wide Range, as specified in the JEDEC JESD8-B specification.
2. I_{IL} is the input leakage current per I/O pin over recommended operating conditions where $-0.3 < V_{IN} < V_{IL}$.
3. I_{IH} is the input leakage current per I/O pin over recommended operating conditions where $V_{IH} < V_{IN} < V_{CCI}$. Input current is larger when operating outside recommended ranges.
4. Note that 3.3 V LVCMOS wide range is applicable to 100 μA drive strength only. The configuration will not operate at the equivalent software default drive strength. These values are for normal ranges only.
5. Currents are measured at 85°C junction temperature.
6. Software default selection is highlighted in gray.

Timing Characteristics

Applies to 1.5 V DC Core Voltage

Table 2-41 • 3.3 V LVCMOS Wide Range Low Slew – Applies to 1.5 V DC Core Voltage

Commercial-Case Conditions: $T_J = 70^\circ\text{C}$, Worst-Case VCC = 1.425 V, Worst-Case VCCI = 2.7 V

Drive Strength	Equivalent Software Default Drive Strength Option ¹	Speed Grade	t _{DOUT}	t _{DP}	t _{DIN}	t _{PY}	t _{PYS}	t _{EOUT}	t _{ZL}	t _{ZH}	t _{LZ}	t _{HZ}	Units
100 μA	2 mA	STD	0.97	5.23	0.19	1.20	1.66	0.66	5.24	5.00	2.47	2.56	ns
100 μA	4 mA	STD	0.97	5.23	0.19	1.20	1.66	0.66	5.24	5.00	2.47	2.56	ns
100 μA	6 mA	STD	0.97	4.27	0.19	1.20	1.66	0.66	4.28	4.12	2.83	3.16	ns
100 μA	8 mA	STD	0.97	4.27	0.19	1.20	1.66	0.66	4.28	4.12	2.83	3.16	ns

Notes:

- Note that 3.3 V LVCMOS wide range is applicable to 100 μA drive strength only. The configuration will not operate at the equivalent software default drive strength. These values are for normal ranges only.
- For specific junction temperature and voltage supply levels, refer to [Table 2-6 on page 2-6](#) for derating values.

Table 2-42 • 3.3 V LVCMOS Wide Range High Slew – Applies to 1.5 V DC Core Voltage

Commercial-Case Conditions: $T_J = 70^\circ\text{C}$, Worst-Case VCC = 1.425 V, Worst-Case VCCI = 2.7 V

Drive Strength	Equivalent Software Default Drive Strength Option ¹	Speed Grade	t _{DOUT}	t _{DP}	t _{DIN}	t _{PY}	t _{PYS}	t _{EOUT}	t _{ZL}	t _{ZH}	t _{LZ}	t _{HZ}	Units
100 μA	2 mA	STD	0.97	3.11	0.19	1.20	1.66	0.66	3.13	2.55	2.47	2.70	ns
100 μA	4 mA	STD	0.97	3.11	0.19	1.20	1.66	0.66	3.13	2.55	2.47	2.70	ns
100 μA	6 mA	STD	0.97	2.56	0.19	1.20	1.66	0.66	2.57	2.02	2.82	3.31	ns
100 μA	8 mA	STD	0.97	2.56	0.19	1.20	1.66	0.66	2.57	2.02	2.82	3.31	ns

Notes:

- Note that 3.3 V LVCMOS wide range is applicable to 100 μA drive strength only. The configuration will not operate at the equivalent software default drive strength. These values are for normal ranges only.
- For specific junction temperature and voltage supply levels, refer to [Table 2-6 on page 2-6](#) for derating values.
- Software default selection highlighted in gray.

Applies to 1.2 V DC Core Voltage

Table 2-43 • 3.3 V LVCMOS Wide Range Low Slew – Applies to 1.2 V DC Core Voltage
Commercial-Case Conditions: $T_J = 70^\circ\text{C}$, Worst-Case VCC = 1.14 V, Worst-Case VCCI = 2.7 V

Drive Strength	Equivalent Software Default Drive Strength Option ¹	Speed Grade	t _{DOUT}	t _{DP}	t _{DIN}	t _{PY}	t _{PYS}	t _{EOUT}	t _{ZL}	t _{ZH}	t _{LZ}	t _{HZ}	Units
100 μA	2 mA	STD	1.55	6.01	0.26	1.31	1.91	1.10	6.01	5.66	3.02	3.49	ns
100 μA	4 mA	STD	1.55	6.01	0.26	1.31	1.91	1.10	6.01	5.66	3.02	3.49	ns
100 μA	6 mA	STD	1.55	5.02	0.26	1.31	1.91	1.10	5.02	4.76	3.38	4.10	ns
100 μA	8 mA	STD	1.55	5.02	0.26	1.31	1.91	1.10	5.02	4.76	3.38	4.10	ns

Notes:

- Note that 3.3 V LVCMOS wide range is applicable to 100 μA drive strength only. The configuration will not operate at the equivalent software default drive strength. These values are for normal ranges only.
- For specific junction temperature and voltage supply levels, refer to [Table 2-6 on page 2-6](#) for derating values.

Table 2-44 • 3.3 V LVCMOS Wide Range High Slew – Applies to 1.2 V DC Core Voltage
Commercial-Case Conditions: $T_J = 70^\circ\text{C}$, Worst-Case VCC = 1.14 V, Worst-Case VCCI = 2.7 V

Drive Strength	Equivalent Software Default Drive Strength Option ¹	Speed Grade	t _{DOUT}	t _{DP}	t _{DIN}	t _{PY}	t _{PYS}	t _{EOUT}	t _{ZL}	t _{ZH}	t _{LZ}	t _{HZ}	Units
100 μA	2 mA	STD	1.55	3.82	0.26	1.31	1.91	1.10	3.82	3.15	3.01	3.65	ns
100 μA	4 mA	STD	1.55	3.82	0.26	1.31	1.91	1.10	3.82	3.15	3.01	3.65	ns
100 μA	6 mA	STD	1.55	3.25	0.26	1.31	1.91	1.10	3.25	2.61	3.38	4.27	ns
100 μA	8 mA	STD	1.55	3.25	0.26	1.31	1.91	1.10	3.25	2.61	3.38	4.27	ns

Notes:

- Note that 3.3 V LVCMOS wide range is applicable to 100 μA drive strength only. The configuration will not operate at the equivalent software default drive strength. These values are for normal ranges only.
- For specific junction temperature and voltage supply levels, refer to [Table 2-6 on page 2-6](#) for derating values.
- Software default selection highlighted in gray.

2.5 V LVCMOS

Low-Voltage CMOS for 2.5 V is an extension of the LVCMOS standard (JESD8-5) used for general purpose 2.5 V applications.

Table 2-45 • Minimum and Maximum DC Input and Output Levels

2.5 V LVCMOS	VIL		VIH		VOL	VOH	I _{OL}	I _{OH}	I _{OSL}	I _{OSH}	I _{IL} ¹	I _{IH} ²
	Min., V	Max., V	Min., V	Max., V	Max., V	Min., V	mA	mA	Max., mA ³	Max., mA ³	μA ⁴	μA ⁴
2 mA	-0.3	0.7	1.7	3.6	0.7	1.7	2	2	16	18	10	10
4 mA	-0.3	0.7	1.7	3.6	0.7	1.7	4	4	16	18	10	10
6 mA	-0.3	0.7	1.7	3.6	0.7	1.7	6	6	32	37	10	10
8 mA	-0.3	0.7	1.7	3.6	0.7	1.7	8	8	32	37	10	10

Notes:

1. I_{IL} is the input leakage current per I/O pin over recommended operating conditions where $-0.3 < V_{IN} < V_{IL}$.
2. I_{IH} is the input leakage current per I/O pin over recommended operating conditions where $V_{IH} < V_{IN} < V_{CCI}$. Input current is larger when operating outside recommended ranges.
3. Currents are measured at high temperature (100°C junction temperature) and maximum voltage.
4. Currents are measured at 85°C junction temperature.
5. Software default selection highlighted in gray.

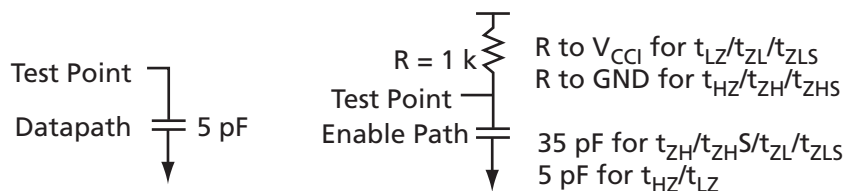

Figure 2-8 • AC Loading

Table 2-46 • 2.5 V LVCMOS AC Waveforms, Measuring Points, and Capacitive Loads

Input LOW (V)	Input HIGH (V)	Measuring Point* (V)	C _{LOAD} (pF)
0	2.5	1.2	5

* Measuring point = V_{trip} . See [Table 2-23 on page 2-20](#) for a complete table of trip points.

Timing Characteristics

Applies to 1.5 V DC Core Voltage

Table 2-47 • 2.5 V LVCMOS Low Slew – Applies to 1.5 V DC Core Voltage

Commercial-Case Conditions: $T_J = 70^\circ\text{C}$, Worst-Case VCC = 1.425 V, Worst-Case VCCI = 2.3 V

Drive Strength	Speed Grade	t_{DOUT}	t_{DP}	t_{DIN}	t_{PY}	t_{PYS}	t_{EOUT}	t_{ZL}	t_{ZH}	t_{LZ}	t_{HZ}	Units
2 mA	STD	0.97	4.13	0.19	1.10	1.24	0.66	4.01	4.13	1.73	1.74	ns
4 mA	STD	0.97	4.13	0.19	1.10	1.24	0.66	4.01	4.13	1.73	1.74	ns
8 mA	STD	0.97	3.39	0.19	1.10	1.24	0.66	3.31	3.39	1.98	2.19	ns
8 mA	STD	0.97	3.39	0.19	1.10	1.24	0.66	3.31	3.39	1.98	2.19	ns

Note: For specific junction temperature and voltage supply levels, refer to [Table 2-6 on page 2-6](#) for derating values.

Table 2-48 • 2.5 V LVCMOS High Slew – Applies to 1.5 V DC Core Voltage

Commercial-Case Conditions: $T_J = 70^\circ\text{C}$, Worst-Case VCC = 1.425 V, Worst-Case VCCI = 2.3 V

Drive Strength	Speed Grade	t_{DOUT}	t_{DP}	t_{DIN}	t_{PY}	t_{PYS}	t_{EOUT}	t_{ZL}	t_{ZH}	t_{LZ}	t_{HZ}	Units
2 mA	STD	0.97	2.19	0.19	1.10	1.24	0.66	2.23	2.11	1.72	1.80	ns
4 mA	STD	0.97	2.19	0.19	1.10	1.24	0.66	2.23	2.11	1.72	1.80	ns
6 mA	STD	0.97	1.81	0.19	1.10	1.24	0.66	1.85	1.63	1.97	2.26	ns
8 mA	STD	0.97	1.81	0.19	1.10	1.24	0.66	1.85	1.63	1.97	2.26	ns

Notes:

1. Software default selection highlighted in gray.
2. For specific junction temperature and voltage supply levels, refer to [Table 2-6 on page 2-6](#) for derating values.

Applies to 1.2 V DC Core Voltage
Table 2-49 • 2.5 LVCMOS Low Slew – Applies to 1.2 V DC Core Voltage
 Commercial-Case Conditions: $T_J = 70^\circ\text{C}$, Worst-Case VCC = 1.14 V, Worst-Case VCCI = 2.3 V

Drive Strength	Speed Grade	t_{DOUT}	t_{DP}	t_{DIN}	t_{PY}	t_{PYS}	t_{EOUT}	t_{zL}	t_{zH}	t_{LZ}	t_{HZ}	Units
2 mA	STD	1.55	4.61	0.26	1.21	1.39	1.10	4.55	4.61	2.15	2.43	ns
4 mA	STD	1.55	4.61	0.26	1.21	1.39	1.10	4.55	4.61	2.15	2.43	ns
6 mA	STD	1.55	3.86	0.26	1.21	1.39	1.10	3.82	3.86	2.41	2.89	ns
8 mA	STD	1.55	3.86	0.26	1.21	1.39	1.10	3.82	3.86	2.41	2.89	ns

Note: For specific junction temperature and voltage supply levels, refer to [Table 2-6 on page 2-6](#) for derating values.

Table 2-50 • 2.5 V LVCMOS High Slew – Applies to 1.2 V DC Core Voltage
 Commercial-Case Conditions: $T_J = 70^\circ\text{C}$, Worst-Case VCC = 1.14 V, Worst-Case VCCI = 2.3 V

Drive Strength	Speed Grade	t_{DOUT}	t_{DP}	t_{DIN}	t_{PY}	t_{PYS}	t_{EOUT}	t_{zL}	t_{zH}	t_{LZ}	t_{HZ}	Units
2 mA	STD	1.55	2.68	0.26	1.21	1.39	1.10	2.72	2.54	2.15	2.51	ns
4 mA	STD	1.55	2.68	0.26	1.21	1.39	1.10	2.72	2.54	2.15	2.51	ns
6 mA	STD	1.55	2.30	0.26	1.21	1.39	1.10	2.33	2.04	2.41	2.99	ns
8 mA	STD	1.55	2.30	0.26	1.21	1.39	1.10	2.33	2.04	2.41	2.99	ns

Notes:

1. Software default selection highlighted in gray.
2. For specific junction temperature and voltage supply levels, refer to [Table 2-6 on page 2-6](#) for derating values.

1.8 V LVCMOS

Low-voltage CMOS for 1.8 V is an extension of the LVCMOS standard (JESD8-5) used for general purpose 1.8 V applications. It uses a 1.8 V input buffer and a push-pull output buffer.

Table 2-51 • Minimum and Maximum DC Input and Output Levels

1.8 V LVCMOS	VIL		VIH		VOL	VOH	I _{OL}	I _{OH}	I _{OSL}	I _{OSH}	I _{IL} ¹	I _{IH} ²
	Min. V	Max. V	Min. V	Max. V	Max. V	Min. V	mA	mA	Max. mA ³	Max. mA ³	μA ⁴	μA ⁴
2 mA	-0.3	0.35 * V _{CCI}	0.65 * V _{CCI}	3.6	0.45	V _{CCI} - 0.45	2	2	9	11	10	10
4 mA	-0.3	0.35 * V _{CCI}	0.65 * V _{CCI}	3.6	0.45	V _{CCI} - 0.45	4	4	17	22	10	10

Notes:

1. I_{IL} is the input leakage current per I/O pin over recommended operating conditions where $-0.3 < V_{IN} < V_{IL}$.
2. I_{IH} is the input leakage current per I/O pin over recommended operating conditions where $V_{IH} < V_{IN} < V_{CCI}$. Input current is larger when operating outside recommended ranges.
3. Currents are measured at high temperature (100°C junction temperature) and maximum voltage.
4. Currents are measured at 85°C junction temperature.
5. Software default selection highlighted in gray.

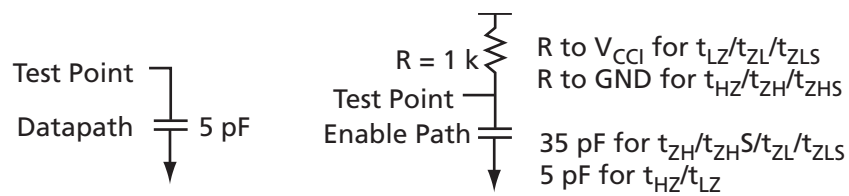

Figure 2-9 • AC Loading

Table 2-52 • 1.8 V LVCMOS AC Waveforms, Measuring Points, and Capacitive Loads

Input LOW (V)	Input HIGH (V)	Measuring Point* (V)	C _{LOAD} (pF)
0	1.8	0.9	5

* Measuring point = V_{trip}. See [Table 2-23 on page 2-20](#) for a complete table of trip points.

Timing Characteristics

Applies to 1.5 V DC Core Voltage

Table 2-53 • 1.8 V LVCMOS Low Slew – Applies to 1.5 V DC Core Voltage

 Commercial-Case Conditions: $T_J = 70^\circ\text{C}$, Worst-Case VCC = 1.425 V, Worst-Case VCCI = 1.7 V

Drive Strength	Speed Grade	t_{DOUT}	t_{DP}	t_{DIN}	t_{PY}	t_{PYS}	t_{EOUT}	t_{ZL}	t_{ZH}	t_{LZ}	t_{HZ}	Units
2 mA	STD	0.97	5.44	0.19	1.03	1.44	0.66	5.25	5.44	1.69	1.35	ns
4 mA	STD	0.97	4.44	0.19	1.03	1.44	0.66	4.37	4.44	1.99	2.11	ns

Note: For specific junction temperature and voltage supply levels, refer to [Table 2-6 on page 2-6](#) for derating values.

Table 2-54 • 1.8 V LVCMOS High Slew – Applies to 1.5 V DC Core Voltage

 Commercial-Case Conditions: $T_J = 70^\circ\text{C}$, Worst-Case VCC = 1.425 V, Worst-Case VCCI = 1.7 V

Drive Strength	Speed Grade	t_{DOUT}	t_{DP}	t_{DIN}	t_{PY}	t_{PYS}	t_{EOUT}	t_{ZL}	t_{ZH}	t_{LZ}	t_{HZ}	Units
2 mA	STD	0.97	2.64	0.19	1.03	1.44	0.66	2.59	2.64	1.69	1.40	ns
4 mA	STD	0.97	2.08	0.19	1.03	1.44	0.66	2.12	1.95	1.99	2.19	ns

Notes:

1. Software default selection highlighted in gray.
2. For specific junction temperature and voltage supply levels, refer to [Table 2-6 on page 2-6](#) for derating values.

Applies to 1.2 V DC Core Voltage

Table 2-55 • 1.8 V LVCMOS Low Slew – Applies to 1.2 V DC Core Voltage

 Commercial-Case Conditions: $T_J = 70^\circ\text{C}$, Worst-Case VCC = 1.14 V, Worst-Case VCCI = 1.7 V

Drive Strength	Speed Grade	t_{DOUT}	t_{DP}	t_{DIN}	t_{PY}	t_{PYS}	t_{EOUT}	t_{ZL}	t_{ZH}	t_{LZ}	t_{HZ}	Units
2 mA	STD	1.55	5.92	0.26	1.13	1.59	1.10	5.72	5.92	2.11	1.95	ns
4 mA	STD	1.55	4.91	0.26	1.13	1.59	1.10	4.82	4.91	2.42	2.73	ns

Note: For specific junction temperature and voltage supply levels, refer to [Table 2-6 on page 2-6](#) for derating values.

Table 2-56 • 1.8 V LVCMOS High Slew – Applies to 1.2 V DC Core Voltage

 Commercial-Case Conditions: $T_J = 70^\circ\text{C}$, Worst-Case VCC = 1.14 V, Worst-Case VCCI = 1.7 V

Drive Strength	Speed Grade	t_{DOUT}	t_{DP}	t_{DIN}	t_{PY}	t_{PYS}	t_{EOUT}	t_{ZL}	t_{ZH}	t_{LZ}	t_{HZ}	Units
2 mA	STD	1.55	3.05	0.26	1.13	1.59	1.10	3.01	3.05	2.10	2.00	ns
4 mA	STD	1.55	2.49	0.26	1.13	1.59	1.10	2.53	2.34	2.42	2.81	ns

Notes:

1. Software default selection highlighted in gray.
2. For specific junction temperature and voltage supply levels, refer to [Table 2-6 on page 2-6](#) for derating values.

1.5 V LVCMOS (JESD8-11)

Low-Voltage CMOS for 1.5 V is an extension of the LVCMOS standard (JESD8-5) used for general purpose 1.5 V applications. It uses a 1.5 V input buffer and a push-pull output buffer.

Table 2-57 • Minimum and Maximum DC Input and Output Levels

1.5 V LVCMOS	VIL		VIH		VOL	VOH	I _{OL}	I _{OH}	I _{OSL}	I _{OSH}	I _{IL} ¹	I _{IH} ²
	Min. V	Max. V	Min. V	Max. V	Max. V	Min. V	mA	mA	Max. mA ³	Max. mA ³	μA ⁴	μA ⁴
2 mA	-0.3	0.35 * V _{CCI}	0.65 * V _{CCI}	3.6	0.25 * V _{CCI}	0.75 * V _{CCI}	2	2	13	16	10	10

Notes:

1. I_{IL} is the input leakage current per I/O pin over recommended operating conditions where $-0.3 < V_{IN} < V_{IL}$.
2. I_{IH} is the input leakage current per I/O pin over recommended operating conditions where $V_{IH} < V_{IN} < V_{CCI}$. Input current is larger when operating outside recommended ranges.
3. Currents are measured at high temperature (100°C junction temperature) and maximum voltage.
4. Currents are measured at 85°C junction temperature.
5. Software default selection highlighted in gray.

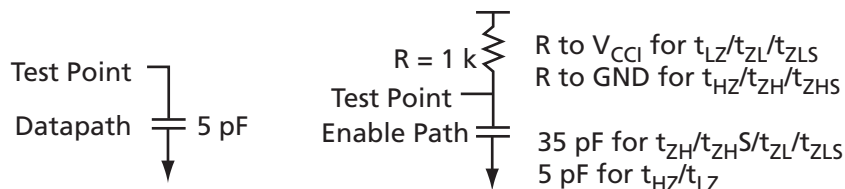

Figure 2-10 • AC Loading

Table 2-58 • 1.5 V LVCMOS AC Waveforms, Measuring Points, and Capacitive Loads

Input LOW (V)	Input HIGH (V)	Measuring Point* (V)	C _{LOAD} (pF)
0	1.5	0.75	5

* Measuring point = V_{trip} . See [Table 2-23 on page 2-20](#) for a complete table of trip points.

Timing Characteristics

Applies to 1.5 V DC Core Voltage

Table 2-59 • 1.5 V LVCMOS Low Slew – Applies to 1.5 V DC Core Voltage

Commercial-Case Conditions: $T_J = 70^\circ\text{C}$, Worst-Case VCC = 1.425 V, Worst-Case VCCI = 1.4 V

Drive Strength	Speed Grade	t_{DOUT}	t_{DP}	t_{DIN}	t_{PY}	t_{PYS}	t_{EOUT}	t_{ZL}	t_{ZH}	t_{LZ}	t_{HZ}	Units
2 mA	STD	0.97	5.39	0.19	1.19	1.62	0.66	5.48	5.39	2.02	2.06	ns

Note: For specific junction temperature and voltage supply levels, refer to [Table 2-6 on page 2-6](#) for derating values.

Table 2-60 • 1.5 V LVCMOS High Slew – Applies to 1.5 V DC Core Voltage

Commercial-Case Conditions: $T_J = 70^\circ\text{C}$, Worst-Case VCC = 1.425 V, Worst-Case VCCI = 1.4 V

Drive Strength	Speed Grade	t_{DOUT}	t_{DP}	t_{DIN}	t_{PY}	t_{PYS}	t_{EOUT}	t_{ZL}	t_{ZH}	t_{LZ}	t_{HZ}	Units
2 mA	STD	0.97	2.39	0.19	1.19	1.62	0.66	2.44	2.24	2.02	2.15	ns

Notes:

1. Software default selection highlighted in gray.
2. For specific junction temperature and voltage supply levels, refer to [Table 2-6 on page 2-6](#) for derating values.

Applies to 1.2 V DC Core Voltage

Table 2-61 • 1.5 V LVCMOS Low Slew – Applies to 1.2 V DC Core Voltage

Commercial-Case Conditions: $T_J = 70^\circ\text{C}$, Worst-Case VCC = 1.14 V, Worst-Case VCCI = 1.4 V

Drive Strength	Speed Grade	t_{DOUT}	t_{DP}	t_{DIN}	t_{PY}	t_{PYS}	t_{EOUT}	t_{ZL}	t_{ZH}	t_{LZ}	t_{HZ}	Units
2 mA	STD	1.55	5.87	0.26	1.27	1.77	1.10	5.92	5.87	2.45	2.65	ns

Note: For specific junction temperature and voltage supply levels, refer to [Table 2-6 on page 2-6](#) for derating values.

Table 2-62 • 1.5 V LVCMOS High Slew – Applies to 1.2 V DC Core Voltage

Commercial-Case Conditions: $T_J = 70^\circ\text{C}$, Worst-Case VCC = 1.14 V, Worst-Case VCCI = 1.4 V

Drive Strength	Speed Grade	t_{DOUT}	t_{DP}	t_{DIN}	t_{PY}	t_{PYS}	t_{EOUT}	t_{ZL}	t_{ZH}	t_{LZ}	t_{HZ}	Units
2 mA	STD	1.55	2.78	0.26	1.27	1.77	1.10	2.82	2.62	2.44	2.74	ns

Notes:

1. Software default selection highlighted in gray.
2. For specific junction temperature and voltage supply levels, refer to [Table 2-6 on page 2-6](#) for derating values.

1.2 V LVCMOS (JESD8-12A)

Low-Voltage CMOS for 1.2 V complies with the LVCMOS standard JESD8-12A for general purpose 1.2 V applications. It uses a 1.2 V input buffer and a push-pull output buffer.

Table 2-63 • Minimum and Maximum DC Input and Output Levels

1.2 V LVCMOS Drive Strength	VIL		VIH		VOL	VOH	I _{OL}	I _{OH}	I _{OSL}	I _{OSH}	I _{IL} ¹	I _{IH} ²
	Min. V	Max. V	Min. V	Max. V	Max. V	Min. V	mA	mA	Max. mA ³	Max. mA ³	μA ⁴	μA ⁴
1 mA	-0.3	0.35 * V _{CCI}	0.65 * V _{CCI}	3.6	0.25 * V _{CCI}	0.75 * V _{CCI}	1	1	10	13	10	10

Notes:

1. I_{IL} is the input leakage current per I/O pin over recommended operating conditions where $-0.3 < V_{IN} < V_{IL}$.
2. I_{IH} is the input leakage current per I/O pin over recommended operating conditions where $V_{IH} < V_{IN} < V_{CCI}$. Input current is larger when operating outside recommended ranges.
3. Currents are measured at high temperature (100°C junction temperature) and maximum voltage.
4. Currents are measured at 85°C junction temperature.
5. Software default selection highlighted in gray.

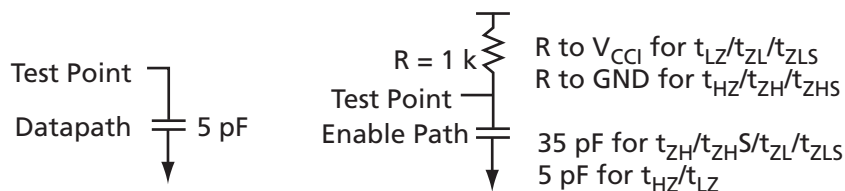

Figure 2-11 • AC Loading

Table 2-64 • 1.2 V LVCMOS AC Waveforms, Measuring Points, and Capacitive Loads

Input LOW (V)	Input HIGH (V)	Measuring Point* (V)	C _{LOAD} (pF)
0	1.2	0.6	5

* Measuring point = V_{trip}. See Table 2-23 on page 2-20 for a complete table of trip points.

Timing Characteristics

Applies to 1.2 V DC Core Voltage

Table 2-65 • 1.2 V LVCMOS Low Slew

Commercial-Case Conditions: T_J = 70°C, Worst-Case VCC = 1.14 V, Worst-Case VCCI = 1.14 V

Drive Strength	Speed Grade	t _{DOUT}	t _{DP}	t _{DIN}	t _{PY}	t _{PYS}	t _{EOUT}	t _{ZL}	t _{ZH}	t _{LZ}	t _{HZ}	Units
1 mA	STD	1.55	8.30	0.26	1.56	2.27	1.10	7.97	7.54	2.56	2.55	ns

Note: For specific junction temperature and voltage supply levels, refer to Table 2-6 on page 2-6 for derating values.

Table 2-66 • 1.2 V LVCMOS High Slew

Commercial-Case Conditions: T_J = 70°C, Worst-Case VCC = 1.14 V, Worst-Case VCCI = 1.14 V

Drive Strength	Speed Grade	t _{DOUT}	t _{DP}	t _{DIN}	t _{PY}	t _{PYS}	t _{EOUT}	t _{ZL}	t _{ZH}	t _{LZ}	t _{HZ}	Units
1 mA	STD	1.55	3.50	0.26	1.56	2.27	1.10	3.37	3.10	2.55	2.66	ns

Note: For specific junction temperature and voltage supply levels, refer to Table 2-6 on page 2-6 for derating values.

1.2 V LVCMOS Wide Range

Table 2-67 • Minimum and Maximum DC Input and Output Levels

1.2 V LVCMOS Wide Range	VIL		VIH		VOL	VOH	IO _L	IO _H	IOS _L	IOS _H	I _{IL} ¹	I _{IH} ²
	Min. V	Max. V	Min. V	Max. V	Max. V	Min. V	mA	mA	Max. mA ³	Max. mA ³	μA ⁴	μA ⁴
1 mA	-0.3	0.3 * VCCI	0.7 * VCCI	3.6	0.1	VCCI - 0.1	100	100	10	13	10	10

Notes:

1. I_{IL} is the input leakage current per I/O pin over recommended operating conditions where $-0.3 < V_{IN} < V_{IL}$.
2. I_{IH} is the input leakage current per I/O pin over recommended operating conditions where $V_{IH} < V_{IN} < V_{CCI}$. Input current is larger when operating outside recommended ranges.
3. Currents are measured at high temperature (100°C junction temperature) and maximum voltage.
4. Currents are measured at 85°C junction temperature.
5. Applicable to IGLoo nano V2 devices operating at $V_{CCI} \geq V_{CC}$.
6. Software default selection highlighted in gray.

Timing Characteristics

Applies to 1.2 V DC Core Voltage

Table 2-68 • 1.2 V LVCMOS Wide Range Low Slew – Applies to 1.2 V DC Core Voltage

Commercial-Case Conditions: $T_J = 70^\circ\text{C}$, Worst-Case VCC = 1.14 V, Worst-Case VCCI = 1.14 V

Drive Strength	Equivalent Software Default Drive Strength Option ¹	Speed Grade	t _{DOUT}	t _{DP}	t _{DIN}	t _{PY}	t _{PYS}	t _{EOUT}	t _{ZL}	t _{ZH}	t _{LZ}	t _{HZ}	Units
100 μA	1 mA	STD	1.55	8.30	0.26	1.56	2.27	1.10	7.97	7.54	2.56	2.55	ns

Notes:

1. Note that 1.2 V LVCMOS wide range is applicable to 100 μA drive strength only. The configuration will not operate at the equivalent software default drive strength. These values are for normal ranges only.
2. For specific junction temperature and voltage supply levels, refer to [Table 2-6 on page 2-6](#) for derating values.

Table 2-69 • 1.2 V LVCMOS Wide Range High Slew – Applies to 1.2 V DC Core Voltage

Commercial-Case Conditions: $T_J = 70^\circ\text{C}$, Worst-Case VCC = 1.14 V, Worst-Case VCCI = 1.14 V

Drive Strength	Equivalent Software Default Drive Strength Option ¹	Speed Grade	t _{DOUT}	t _{DP}	t _{DIN}	t _{PY}	t _{PYS}	t _{EOUT}	t _{ZL}	t _{ZH}	t _{LZ}	t _{HZ}	Units
100 μA	1 mA	STD	1.55	3.50	0.26	1.56	2.27	1.10	3.37	3.10	2.55	2.66	ns

Notes:

1. Note that 1.2 V LVCMOS wide range is applicable to 100 μA drive strength only. The configuration will not operate at the equivalent software default drive strength. These values are for normal ranges only.
2. For specific junction temperature and voltage supply levels, refer to [Table 2-6 on page 2-6](#) for derating values.
3. Software default selection highlighted in gray.

I/O Register Specifications

Fully Registered I/O Buffers with Asynchronous Preset

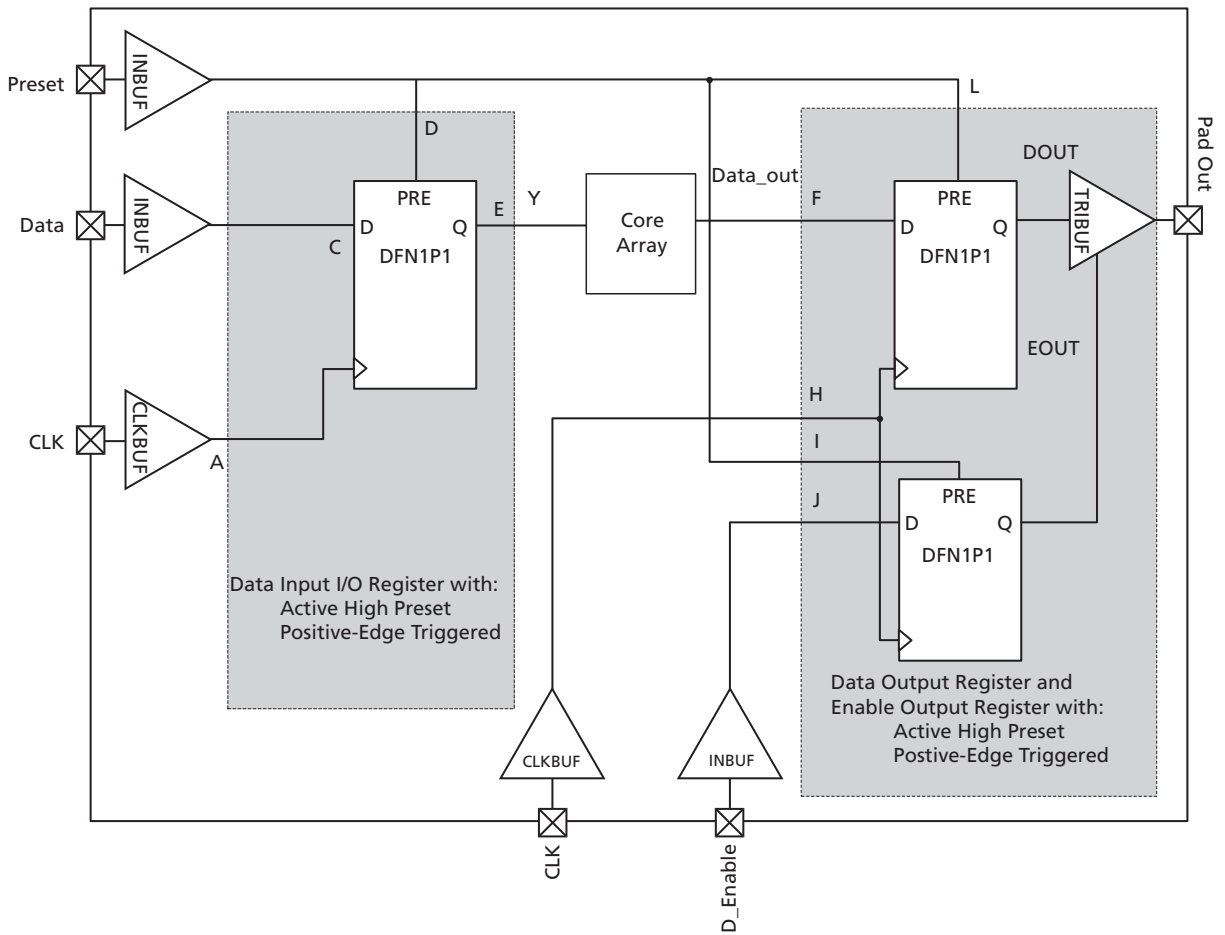

Figure 2-12 • Timing Model of Registered I/O Buffers with Asynchronous Preset

Table 2-70 • Parameter Definition and Measuring Nodes

Parameter Name	Parameter Definition	Measuring Nodes (from, to)*
t_{OCLKQ}	Clock-to-Q of the Output Data Register	H, DOUT
t_{OSUD}	Data Setup Time for the Output Data Register	F, H
t_{OHD}	Data Hold Time for the Output Data Register	F, H
t_{OPRE2Q}	Asynchronous Preset-to-Q of the Output Data Register	L, DOUT
$t_{OREMPRE}$	Asynchronous Preset Removal Time for the Output Data Register	L, H
$t_{ORECPRE}$	Asynchronous Preset Recovery Time for the Output Data Register	L, H
t_{OECLKQ}	Clock-to-Q of the Output Enable Register	H, EOUT
t_{OESUD}	Data Setup Time for the Output Enable Register	J, H
t_{OEHD}	Data Hold Time for the Output Enable Register	J, H
$t_{OEPRE2Q}$	Asynchronous Preset-to-Q of the Output Enable Register	I, EOUT
$t_{OEREMPRE}$	Asynchronous Preset Removal Time for the Output Enable Register	I, H
$t_{OERECPRE}$	Asynchronous Preset Recovery Time for the Output Enable Register	I, H
t_{ICLKQ}	Clock-to-Q of the Input Data Register	A, E
t_{ISUD}	Data Setup Time for the Input Data Register	C, A
t_{IHD}	Data Hold Time for the Input Data Register	C, A
t_{IPRE2Q}	Asynchronous Preset-to-Q of the Input Data Register	D, E
$t_{IREMPRE}$	Asynchronous Preset Removal Time for the Input Data Register	D, A
$t_{IRECPRE}$	Asynchronous Preset Recovery Time for the Input Data Register	D, A

* See [Figure 2-12 on page 2-41](#) for more information.

Fully Registered I/O Buffers with Asynchronous Clear

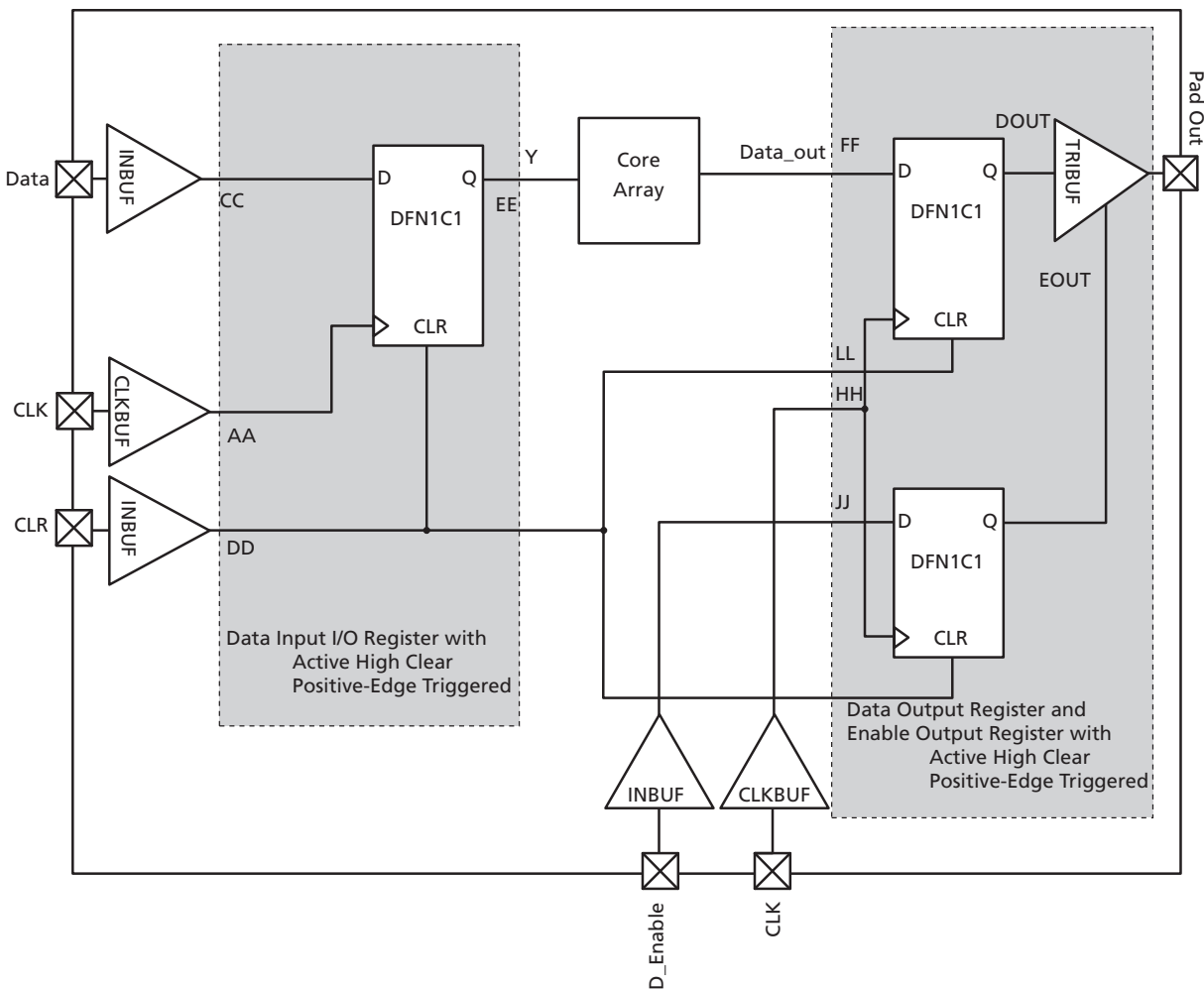

Figure 2-13 • Timing Model of the Registered I/O Buffers with Asynchronous Clear

Table 2-71 • Parameter Definition and Measuring Nodes

Parameter Name	Parameter Definition	Measuring Nodes (from, to)*
t_{OCLKQ}	Clock-to-Q of the Output Data Register	HH, DOUT
t_{OSUD}	Data Setup Time for the Output Data Register	FF, HH
t_{OHD}	Data Hold Time for the Output Data Register	FF, HH
t_{OCLR2Q}	Asynchronous Clear-to-Q of the Output Data Register	LL, DOUT
t_{OREMCLR}	Asynchronous Clear Removal Time for the Output Data Register	LL, HH
t_{ORECCLR}	Asynchronous Clear Recovery Time for the Output Data Register	LL, HH
t_{OECLKQ}	Clock-to-Q of the Output Enable Register	HH, EOUT
t_{OESUD}	Data Setup Time for the Output Enable Register	JJ, HH
t_{OEHD}	Data Hold Time for the Output Enable Register	JJ, HH
t_{OECLR2Q}	Asynchronous Clear-to-Q of the Output Enable Register	II, EOUT
t_{OEREMCLR}	Asynchronous Clear Removal Time for the Output Enable Register	II, HH
t_{OERECCLR}	Asynchronous Clear Recovery Time for the Output Enable Register	II, HH
t_{ICLKQ}	Clock-to-Q of the Input Data Register	AA, EE
t_{ISUD}	Data Setup Time for the Input Data Register	CC, AA
t_{IHD}	Data Hold Time for the Input Data Register	CC, AA
t_{ICLR2Q}	Asynchronous Clear-to-Q of the Input Data Register	DD, EE
t_{IREMCLR}	Asynchronous Clear Removal Time for the Input Data Register	DD, AA
t_{IRECCLR}	Asynchronous Clear Recovery Time for the Input Data Register	DD, AA

* See [Figure 2-13](#) on [page 2-43](#) for more information.

Input Register

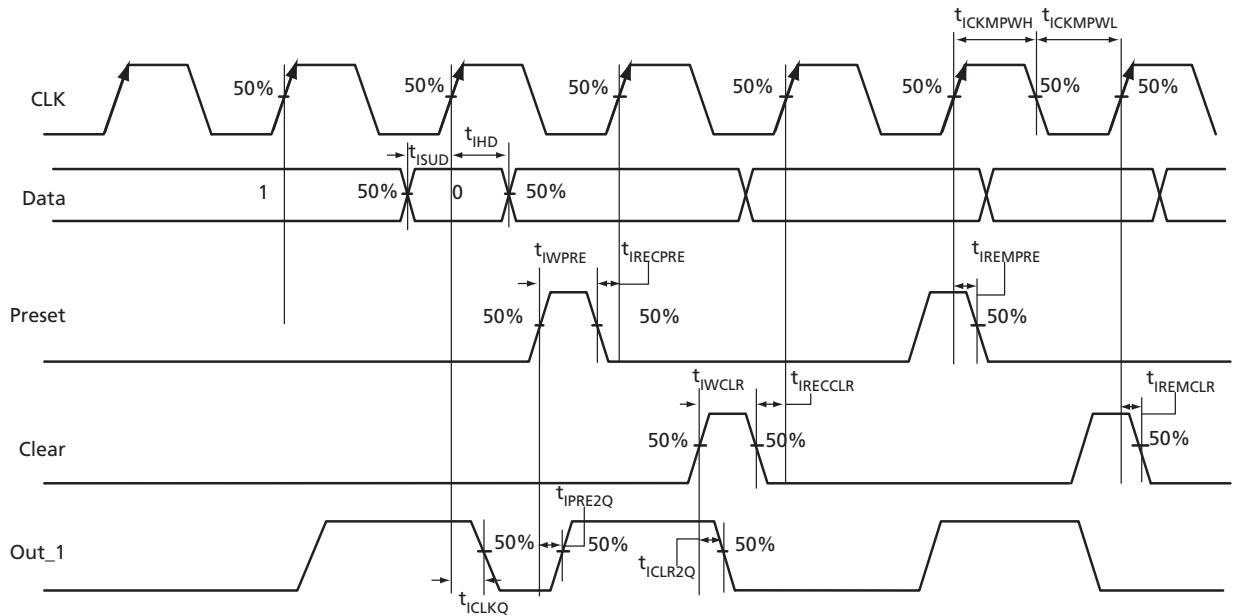

Figure 2-14 • Input Register Timing Diagram

Timing Characteristics

1.5 V DC Core Voltage

Table 2-72 • Input Data Register Propagation Delays

Commercial-Case Conditions: $T_J = 70^\circ\text{C}$, Worst-Case $V_{CC} = 1.425\text{ V}$

Parameter	Description	Std.	Units
t_{CLKQ}	Clock-to-Q of the Input Data Register	0.42	ns
t_{ISUD}	Data Setup Time for the Input Data Register	0.47	ns
t_{IHD}	Data Hold Time for the Input Data Register	0.00	ns
t_{CLR2Q}	Asynchronous Clear-to-Q of the Input Data Register	0.79	ns
t_{PRE2Q}	Asynchronous Preset-to-Q of the Input Data Register	0.79	ns
t_{REMCLR}	Asynchronous Clear Removal Time for the Input Data Register	0.00	ns
t_{RECCLR}	Asynchronous Clear Recovery Time for the Input Data Register	0.24	ns
t_{REMPRE}	Asynchronous Preset Removal Time for the Input Data Register	0.00	ns
t_{RECPRE}	Asynchronous Preset Recovery Time for the Input Data Register	0.24	ns
t_{WCLR}	Asynchronous Clear Minimum Pulse Width for the Input Data Register	0.19	ns
t_{WPRE}	Asynchronous Preset Minimum Pulse Width for the Input Data Register	0.19	ns
t_{CKMPWH}	Clock Minimum Pulse Width HIGH for the Input Data Register	0.31	ns
t_{CKMPWL}	Clock Minimum Pulse Width LOW for the Input Data Register	0.28	ns

Note: For specific junction temperature and voltage supply levels, refer to Table 2-6 on page 2-6 for derating values.

1.2 V DC Core Voltage

Table 2-73 • Input Data Register Propagation Delays
Commercial-Case Conditions: $T_J = 70^\circ\text{C}$, Worst-Case $V_{CC} = 1.14\text{ V}$

Parameter	Description	Std.	Units
t_{CLKQ}	Clock-to-Q of the Input Data Register	0.68	ns
t_{SUD}	Data Setup Time for the Input Data Register	0.97	ns
t_{HD}	Data Hold Time for the Input Data Register	0.00	ns
t_{CLR2Q}	Asynchronous Clear-to-Q of the Input Data Register	1.19	ns
t_{PRE2Q}	Asynchronous Preset-to-Q of the Input Data Register	1.19	ns
t_{REMCLR}	Asynchronous Clear Removal Time for the Input Data Register	0.00	ns
t_{RECCLR}	Asynchronous Clear Recovery Time for the Input Data Register	0.24	ns
t_{REMPRE}	Asynchronous Preset Removal Time for the Input Data Register	0.00	ns
t_{RECPRE}	Asynchronous Preset Recovery Time for the Input Data Register	0.24	ns
t_{WCLR}	Asynchronous Clear Minimum Pulse Width for the Input Data Register	0.19	ns
t_{WPRE}	Asynchronous Preset Minimum Pulse Width for the Input Data Register	0.19	ns
t_{CKMPWH}	Clock Minimum Pulse Width HIGH for the Input Data Register	0.31	ns
t_{CKMPWL}	Clock Minimum Pulse Width LOW for the Input Data Register	0.28	ns

Note: For specific junction temperature and voltage supply levels, refer to [Table 2-7 on page 2-7](#) for derating values.

Output Register

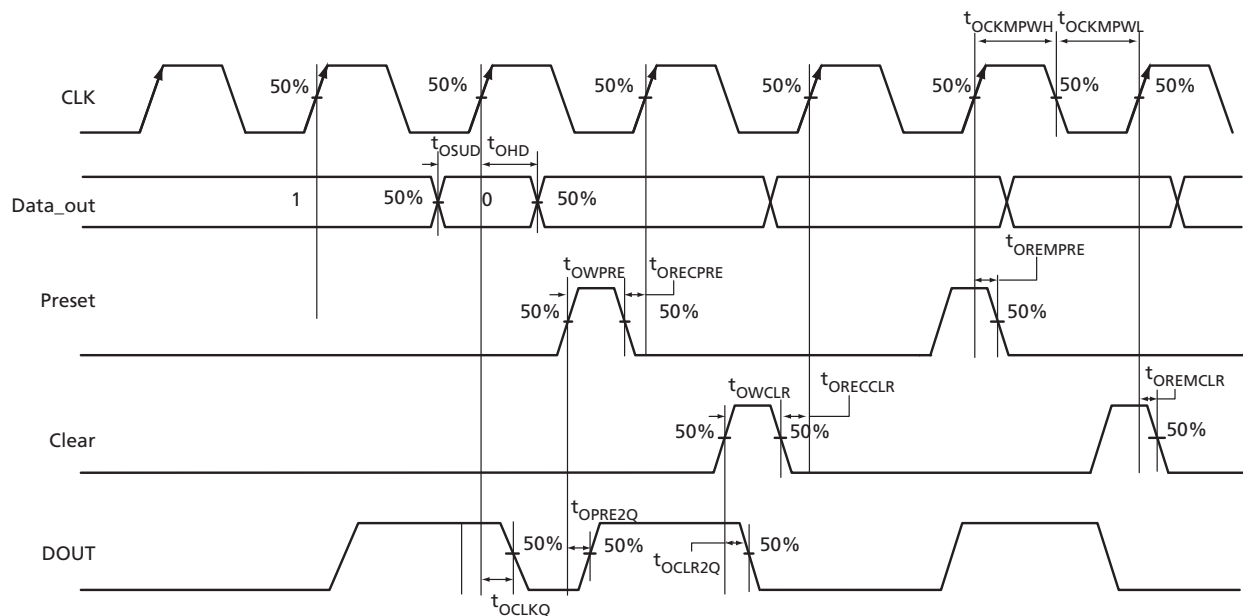

Figure 2-15 • Output Register Timing Diagram

Timing Characteristics

1.5 V DC Core Voltage

Table 2-74 • Output Data Register Propagation Delays

Commercial-Case Conditions: $T_J = 70^\circ\text{C}$, Worst-Case $V_{CC} = 1.425\text{ V}$

Parameter	Description	Std.	Units
t_{OCLKQ}	Clock-to-Q of the Output Data Register	1.00	ns
t_{OSUD}	Data Setup Time for the Output Data Register	0.51	ns
t_{OHD}	Data Hold Time for the Output Data Register	0.00	ns
t_{OCLR2Q}	Asynchronous Clear-to-Q of the Output Data Register	1.34	ns
t_{OPRE2Q}	Asynchronous Preset-to-Q of the Output Data Register	1.34	ns
t_{OEMCLR}	Asynchronous Clear Removal Time for the Output Data Register	0.00	ns
$t_{ORECCLR}$	Asynchronous Clear Recovery Time for the Output Data Register	0.24	ns
t_{OEMPRE}	Asynchronous Preset Removal Time for the Output Data Register	0.00	ns
$t_{ORECPRE}$	Asynchronous Preset Recovery Time for the Output Data Register	0.24	ns
t_{OWCLR}	Asynchronous Clear Minimum Pulse Width for the Output Data Register	0.19	ns
t_{OWPRE}	Asynchronous Preset Minimum Pulse Width for the Output Data Register	0.19	ns
$t_{OCKMPWH}$	Clock Minimum Pulse Width HIGH for the Output Data Register	0.31	ns
$t_{OCKMPWL}$	Clock Minimum Pulse Width LOW for the Output Data Register	0.28	ns

Note: For specific junction temperature and voltage supply levels, refer to Table 2-6 on page 2-6 for derating values.

1.2 V DC Core Voltage

Table 2-75 • Output Data Register Propagation Delays
Commercial-Case Conditions: $T_J = 70^\circ\text{C}$, Worst-Case $V_{CC} = 1.14\text{ V}$

Parameter	Description	Std.	Units
t_{OCLKQ}	Clock-to-Q of the Output Data Register	1.52	ns
t_{OSUD}	Data Setup Time for the Output Data Register	1.15	ns
t_{OHD}	Data Hold Time for the Output Data Register	0.00	ns
t_{OCLR2Q}	Asynchronous Clear-to-Q of the Output Data Register	1.96	ns
t_{OPRE2Q}	Asynchronous Preset-to-Q of the Output Data Register	1.96	ns
$t_{OREMCLR}$	Asynchronous Clear Removal Time for the Output Data Register	0.00	ns
$t_{ORECCLR}$	Asynchronous Clear Recovery Time for the Output Data Register	0.24	ns
$t_{OREMPRE}$	Asynchronous Preset Removal Time for the Output Data Register	0.00	ns
$t_{ORECPRE}$	Asynchronous Preset Recovery Time for the Output Data Register	0.24	ns
t_{OWCLR}	Asynchronous Clear Minimum Pulse Width for the Output Data Register	0.19	ns
t_{OWPRE}	Asynchronous Preset Minimum Pulse Width for the Output Data Register	0.19	ns
$t_{OCKMPWH}$	Clock Minimum Pulse Width HIGH for the Output Data Register	0.31	ns
$t_{OCKMPWL}$	Clock Minimum Pulse Width LOW for the Output Data Register	0.28	ns

Note: For specific junction temperature and voltage supply levels, refer to [Table 2-7 on page 2-7](#) for derating values.

Output Enable Register

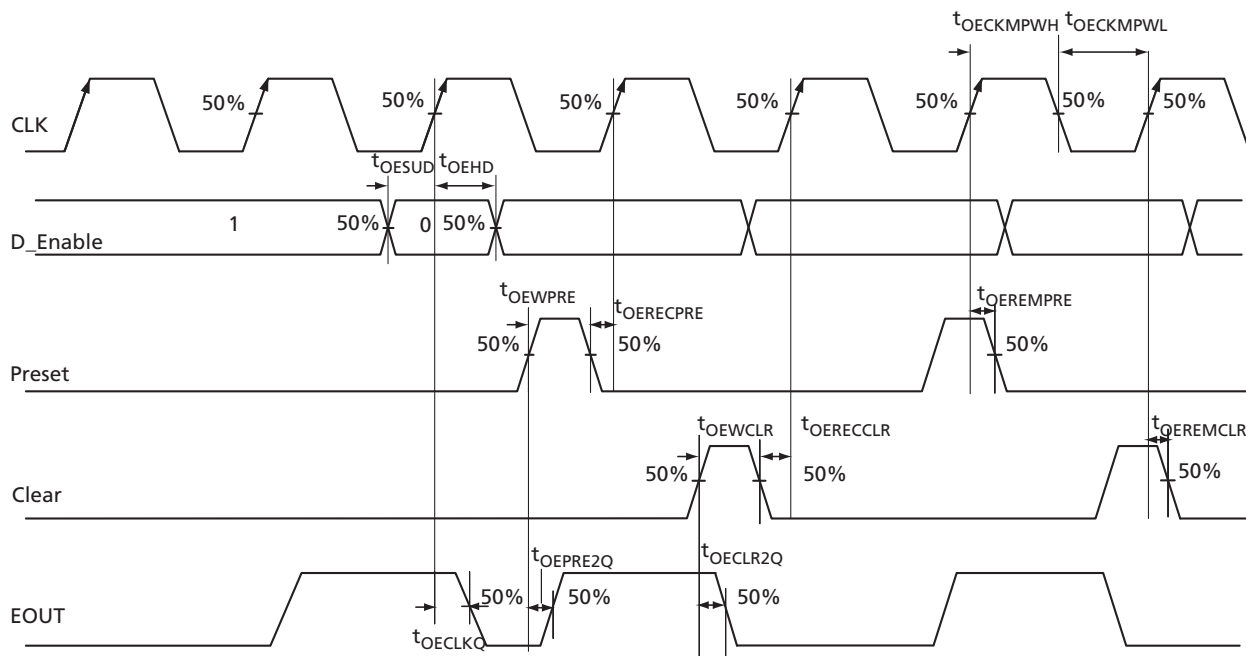

Figure 2-16 • Output Enable Register Timing Diagram

Timing Characteristics

1.5 V DC Core Voltage

Table 2-76 • Output Enable Register Propagation Delays

Commercial-Case Conditions: $T_J = 70^\circ\text{C}$, Worst-Case $V_{CC} = 1.425\text{ V}$

Parameter	Description	Std.	Units
t_{OECLKQ}	Clock-to-Q of the Output Enable Register	0.75	ns
t_{OESUD}	Data Setup Time for the Output Enable Register	0.51	ns
t_{OEHD}	Data Hold Time for the Output Enable Register	0.00	ns
$t_{OECLR2Q}$	Asynchronous Clear-to-Q of the Output Enable Register	1.13	ns
$t_{OEPRE2Q}$	Asynchronous Preset-to-Q of the Output Enable Register	1.13	ns
$t_{OEREMCLR}$	Asynchronous Clear Removal Time for the Output Enable Register	0.00	ns
$t_{OERECCLR}$	Asynchronous Clear Recovery Time for the Output Enable Register	0.24	ns
$t_{OEREMPRE}$	Asynchronous Preset Removal Time for the Output Enable Register	0.00	ns
$t_{OERECPRE}$	Asynchronous Preset Recovery Time for the Output Enable Register	0.24	ns
t_{OEWCLR}	Asynchronous Clear Minimum Pulse Width for the Output Enable Register	0.19	ns
t_{OEWPRE}	Asynchronous Preset Minimum Pulse Width for the Output Enable Register	0.19	ns
$t_{OECKMPWH}$	Clock Minimum Pulse Width HIGH for the Output Enable Register	0.31	ns
$t_{OECKMPWL}$	Clock Minimum Pulse Width LOW for the Output Enable Register	0.28	ns

Note: For specific junction temperature and voltage supply levels, refer to Table 2-6 on page 2-6 for derating values.

1.2 V DC Core Voltage

Table 2-77 • Output Enable Register Propagation Delays
Commercial-Case Conditions: $T_J = 70^\circ\text{C}$, Worst-Case $V_{CC} = 1.14\text{ V}$

Parameter	Description	Std.	Units
t_{OECLKQ}	Clock-to-Q of the Output Enable Register	1.10	ns
t_{OESUD}	Data Setup Time for the Output Enable Register	1.15	ns
t_{OEHD}	Data Hold Time for the Output Enable Register	0.00	ns
$t_{OECLR2Q}$	Asynchronous Clear-to-Q of the Output Enable Register	1.65	ns
$t_{OEPRE2Q}$	Asynchronous Preset-to-Q of the Output Enable Register	1.65	ns
$t_{OEREMCLR}$	Asynchronous Clear Removal Time for the Output Enable Register	0.00	ns
$t_{OERECCLR}$	Asynchronous Clear Recovery Time for the Output Enable Register	0.24	ns
$t_{OEREMPRE}$	Asynchronous Preset Removal Time for the Output Enable Register	0.00	ns
$t_{OERECPRE}$	Asynchronous Preset Recovery Time for the Output Enable Register	0.24	ns
$t_{OEWCCLR}$	Asynchronous Clear Minimum Pulse Width for the Output Enable Register	0.19	ns
t_{OEWPRE}	Asynchronous Preset Minimum Pulse Width for the Output Enable Register	0.19	ns
$t_{OECKMPWH}$	Clock Minimum Pulse Width HIGH for the Output Enable Register	0.31	ns
$t_{OECKMPWL}$	Clock Minimum Pulse Width LOW for the Output Enable Register	0.28	ns

Note: For specific junction temperature and voltage supply levels, refer to [Table 2-7 on page 2-7](#) for derating values.

DDR Module Specifications

Note: DDR is not supported for AGLN010, AGLN015, and AGLN020 devices.

Input DDR Module

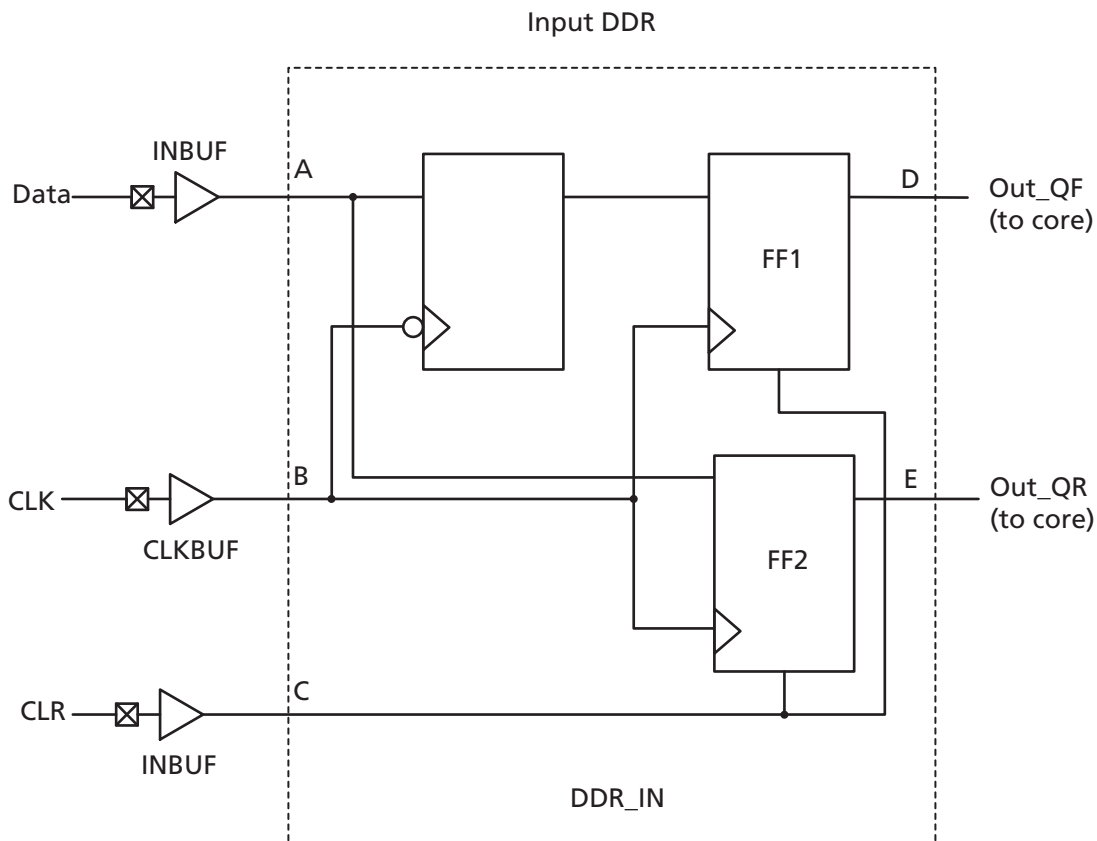
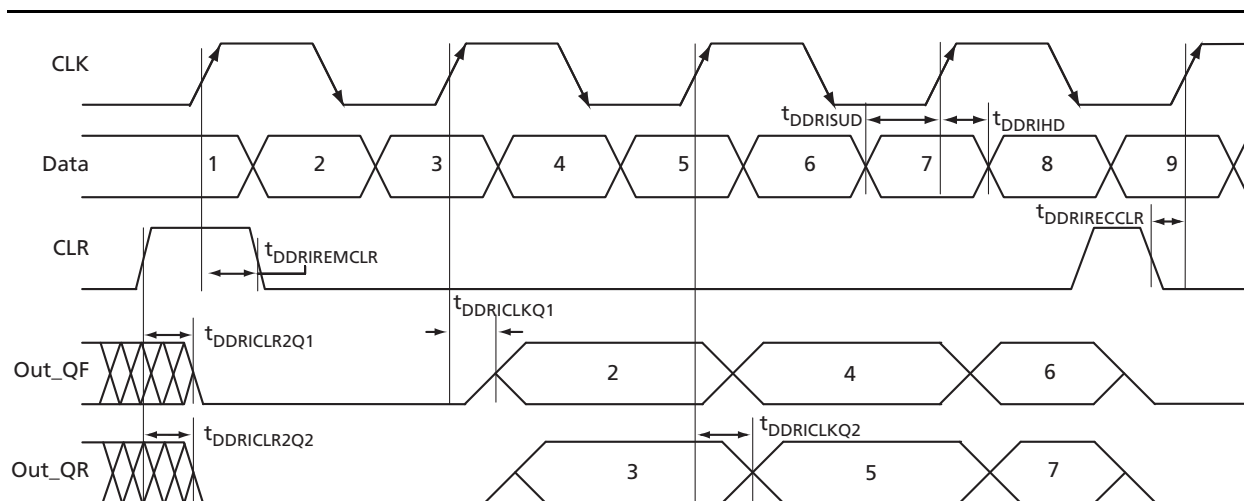

Figure 2-17 • Input DDR Timing Model

Table 2-78 • Parameter Definitions

Parameter Name	Parameter Definition	Measuring Nodes (from, to)
$t_{\text{DDRICKLQ1}}$	Clock-to-Out Out_QR	B, D
$t_{\text{DDRICKLQ2}}$	Clock-to-Out Out_QF	B, E
t_{DDRISUD}	Data Setup Time of DDR input	A, B
t_{DDRIHD}	Data Hold Time of DDR input	A, B
$t_{\text{DDRICLR2Q1}}$	Clear-to-Out Out_QR	C, D
$t_{\text{DDRICLR2Q2}}$	Clear-to-Out Out_QF	C, E
$t_{\text{DDRIREMCLR}}$	Clear Removal	C, B
$t_{\text{DDRIRECCLR}}$	Clear Recovery	C, B

Figure 2-18 • Input DDR Timing Diagram

Timing Characteristics

1.5 V DC Core Voltage

Table 2-79 • Input DDR Propagation Delays

 Commercial-Case Conditions: $T_J = 70^\circ\text{C}$, Worst-Case $V_{CC} = 1.25\text{ V}$

Parameter	Description	Std.	Units
t_{DDRICKQ1}	Clock-to-Out Out_QR for Input DDR	0.48	ns
t_{DDRICKQ2}	Clock-to-Out Out_QF for Input DDR	0.65	ns
t_{DDRISUD1}	Data Setup for Input DDR (negedge)	0.50	ns
t_{DDRISUD2}	Data Setup for Input DDR (posedge)	0.40	ns
t_{DDRHD1}	Data Hold for Input DDR (negedge)	0.00	ns
t_{DDRHD2}	Data Hold for Input DDR (posedge)	0.00	ns
$t_{\text{DDRICLR2Q1}}$	Asynchronous Clear-to-Out Out_QR for Input DDR	0.82	ns
$t_{\text{DDRICLR2Q2}}$	Asynchronous Clear-to-Out Out_QF for Input DDR	0.98	ns
t_{DDRRECLR}	Asynchronous Clear Removal Time for Input DDR	0.00	ns
$t_{\text{DDRRECCLR}}$	Asynchronous Clear Recovery Time for Input DDR	0.23	ns
t_{DDRWCLR}	Asynchronous Clear Minimum Pulse Width for Input DDR	0.19	ns
$t_{\text{DDRICKMPWH}}$	Clock Minimum Pulse Width HIGH for Input DDR	0.31	ns
$t_{\text{DDRICKMPWL}}$	Clock Minimum Pulse Width LOW for Input DDR	0.28	ns
F_{DDRIMAX}	Maximum Frequency for Input DDR	250.00	MHz

Note: For specific junction temperature and voltage supply levels, refer to Table 2-7 on page 2-7 for derating values.

1.2 V DC Core Voltage

Table 2-80 • Input DDR Propagation Delays

Commercial-Case Conditions: $T_J = 70^\circ\text{C}$, Worst-Case $V_{CC} = 1.14\text{ V}$

Parameter	Description	Std.	Units
t_{DDRICKQ1}	Clock-to-Out Out_QR for Input DDR	0.76	ns
t_{DDRICKQ2}	Clock-to-Out Out_QF for Input DDR	0.94	ns
t_{DDRISUD1}	Data Setup for Input DDR (negedge)	0.93	ns
t_{DDRISUD2}	Data Setup for Input DDR (posedge)	0.84	ns
t_{DDRILD1}	Data Hold for Input DDR (negedge)	0.00	ns
t_{DDRILD2}	Data Hold for Input DDR (posedge)	0.00	ns
$t_{\text{DDRICLR2Q1}}$	Asynchronous Clear-to-Out Out_QR for Input DDR	1.23	ns
$t_{\text{DDRICLR2Q2}}$	Asynchronous Clear-to-Out Out_QF for Input DDR	1.42	ns
$t_{\text{DDRIRECLR}}$	Asynchronous Clear Removal Time for Input DDR	0.00	ns
$t_{\text{DDRIRECCLR}}$	Asynchronous Clear Recovery Time for Input DDR	0.24	ns
t_{DDRWCCLR}	Asynchronous Clear Minimum Pulse Width for Input DDR	0.19	ns
$t_{\text{DDRICKMPWH}}$	Clock Minimum Pulse Width HIGH for Input DDR	0.31	ns
$t_{\text{DDRICKMPWL}}$	Clock Minimum Pulse Width LOW for Input DDR	0.28	ns
F_{DDRIMAX}	Maximum Frequency for Input DDR	160.00	MHz

Note: For specific junction temperature and voltage supply levels, refer to Table 2-7 on page 2-7 for derating values.

Output DDR Module

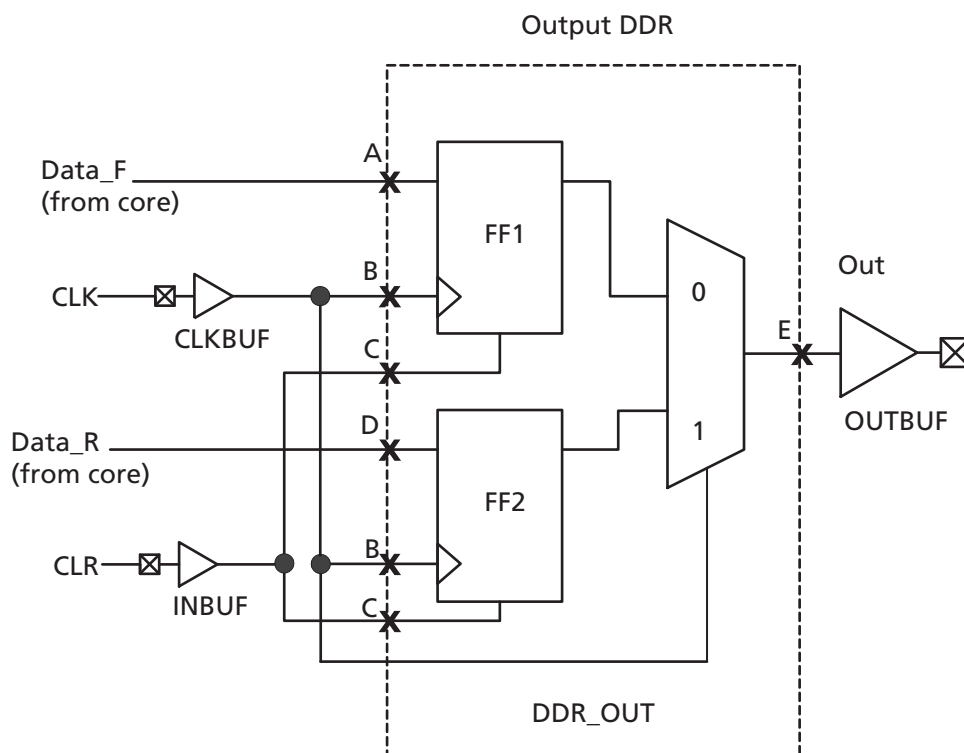
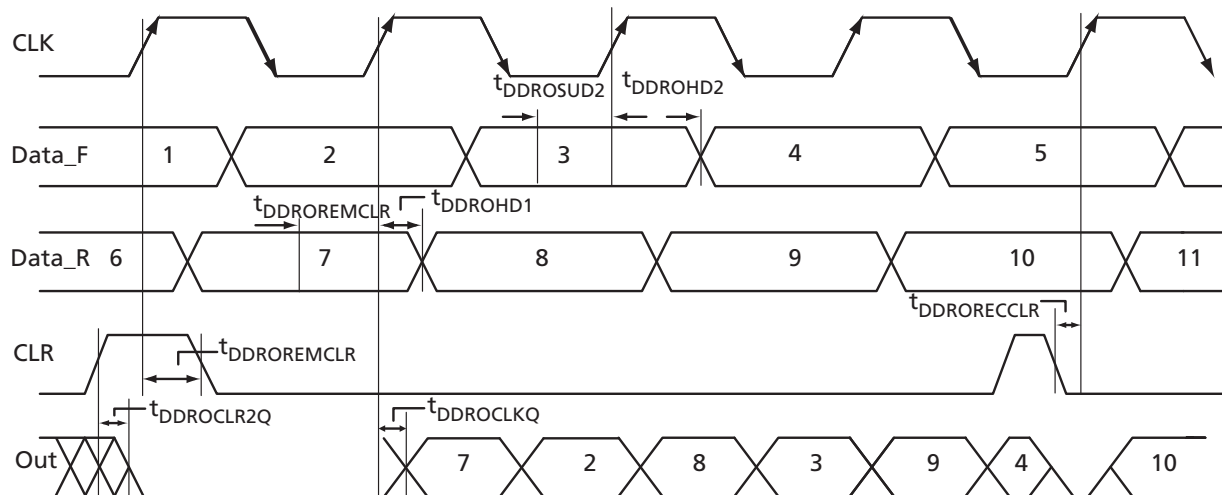

Figure 2-19 • Output DDR Timing Model

Table 2-81 • Parameter Definitions

Parameter Name	Parameter Definition	Measuring Nodes (from, to)
$t_{DDROCLKQ}$	Clock-to-Out	B, E
$t_{DDROCLR2Q}$	Asynchronous Clear-to-Out	C, E
$t_{DDROREMCLR}$	Clear Removal	C, B
$t_{DDRORECCLR}$	Clear Recovery	C, B
$t_{DDROSUD1}$	Data Setup Data_F	A, B
$t_{DDROSUD2}$	Data Setup Data_R	D, B
$t_{DDROHD1}$	Data Hold Data_F	A, B
$t_{DDROHD2}$	Data Hold Data_R	D, B

Figure 2-20 • Output DDR Timing Diagram

Timing Characteristics

1.5 V DC Core Voltage

Table 2-82 • Output DDR Propagation Delays
Table 2-83 • Commercial-Case Conditions: $T_J = 70^\circ\text{C}$, Worst-Case $V_{CC} = 1.425\text{ V}$

Parameter	Description	Std.	Units
t_{DDROCLKQ}	Clock-to-Out of DDR for Output DDR	1.07	ns
t_{DDROSUD1}	Data_F Data Setup for Output DDR	0.67	ns
t_{DDROSUD2}	Data_R Data Setup for Output DDR	0.67	ns
t_{DDROHD1}	Data_F Data Hold for Output DDR	0.00	ns
t_{DDROHD2}	Data_R Data Hold for Output DDR	0.00	ns
$t_{\text{DDROCLR2Q}}$	Asynchronous Clear-to-Out for Output DDR	1.38	ns
$t_{\text{DDROEMCLR}}$	Asynchronous Clear Removal Time for Output DDR	0.00	ns
t_{DDROECLR}	Asynchronous Clear Recovery Time for Output DDR	0.23	ns
$t_{\text{DDROWCLR1}}$	Asynchronous Clear Minimum Pulse Width for Output DDR	0.19	ns
$t_{\text{DDROCKMPWH}}$	Clock Minimum Pulse Width HIGH for the Output DDR	0.31	ns
$t_{\text{DDROCKMPWL}}$	Clock Minimum Pulse Width LOW for the Output DDR	0.28	ns
F_{DDOMAX}	Maximum Frequency for the Output DDR	250.00	MHz

Note: For specific junction temperature and voltage supply levels, refer to Table 2-6 on page 2-6 for derating values.

1.2 V DC Core Voltage

Table 2-84 • Output DDR Propagation Delays

 Commercial-Case Conditions: $T_J = 70^\circ\text{C}$, Worst-Case $V_{CC} = 1.14\text{ V}$

Parameter	Description	Std.	Units
$t_{DDROCLKQ}$	Clock-to-Out of DDR for Output DDR	1.60	ns
$t_{DDROSUD1}$	Data_F Data Setup for Output DDR	1.09	ns
$t_{DDROSUD2}$	Data_R Data Setup for Output DDR	1.16	ns
$t_{DDROHD1}$	Data_F Data Hold for Output DDR	0.00	ns
$t_{DDROHD2}$	Data_R Data Hold for Output DDR	0.00	ns
$t_{DDROCLR2Q}$	Asynchronous Clear-to-Out for Output DDR	1.99	ns
$t_{DDROREMCLR}$	Asynchronous Clear Removal Time for Output DDR	0.00	ns
$t_{DDRORECCLR}$	Asynchronous Clear Recovery Time for Output DDR	0.24	ns
$t_{DDROWCLR1}$	Asynchronous Clear Minimum Pulse Width for Output DDR	0.19	ns
$t_{DDROCKMPWH}$	Clock Minimum Pulse Width HIGH for the Output DDR	0.31	ns
$t_{DDROCKMPWL}$	Clock Minimum Pulse Width LOW for the Output DDR	0.28	ns
F_{DDOMAX}	Maximum Frequency for the Output DDR	160.00	MHz

Note: For specific junction temperature and voltage supply levels, refer to [Table 2-7 on page 2-7](#) for derating values.

VersaTile Characteristics

VersaTile Specifications as a Combinatorial Module

The IGLOO nano library offers all combinations of LUT-3 combinatorial functions. In this section, timing characteristics are presented for a sample of the library. For more details, refer to the *Fusion, IGLOO/e, and ProASIC3/ E Macro Library Guide*.

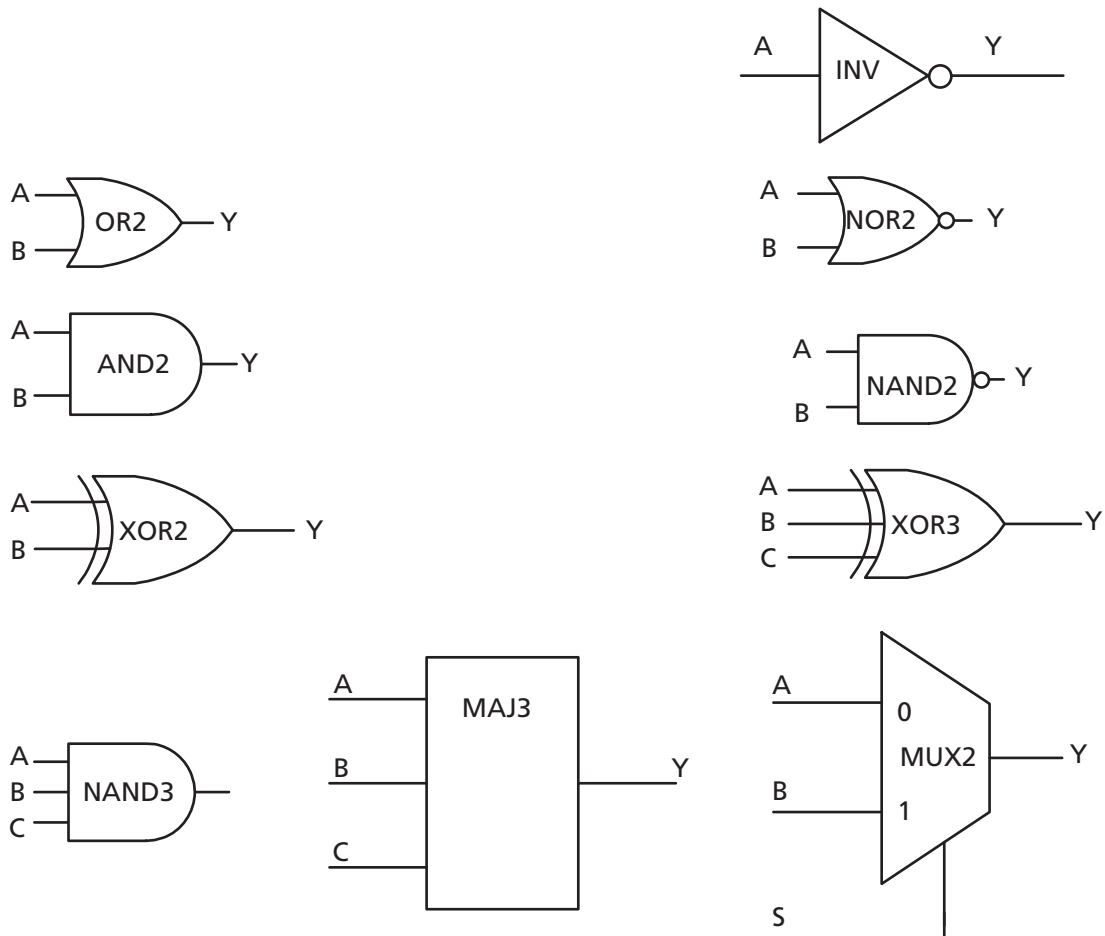

Figure 2-21 • Sample of Combinatorial Cells

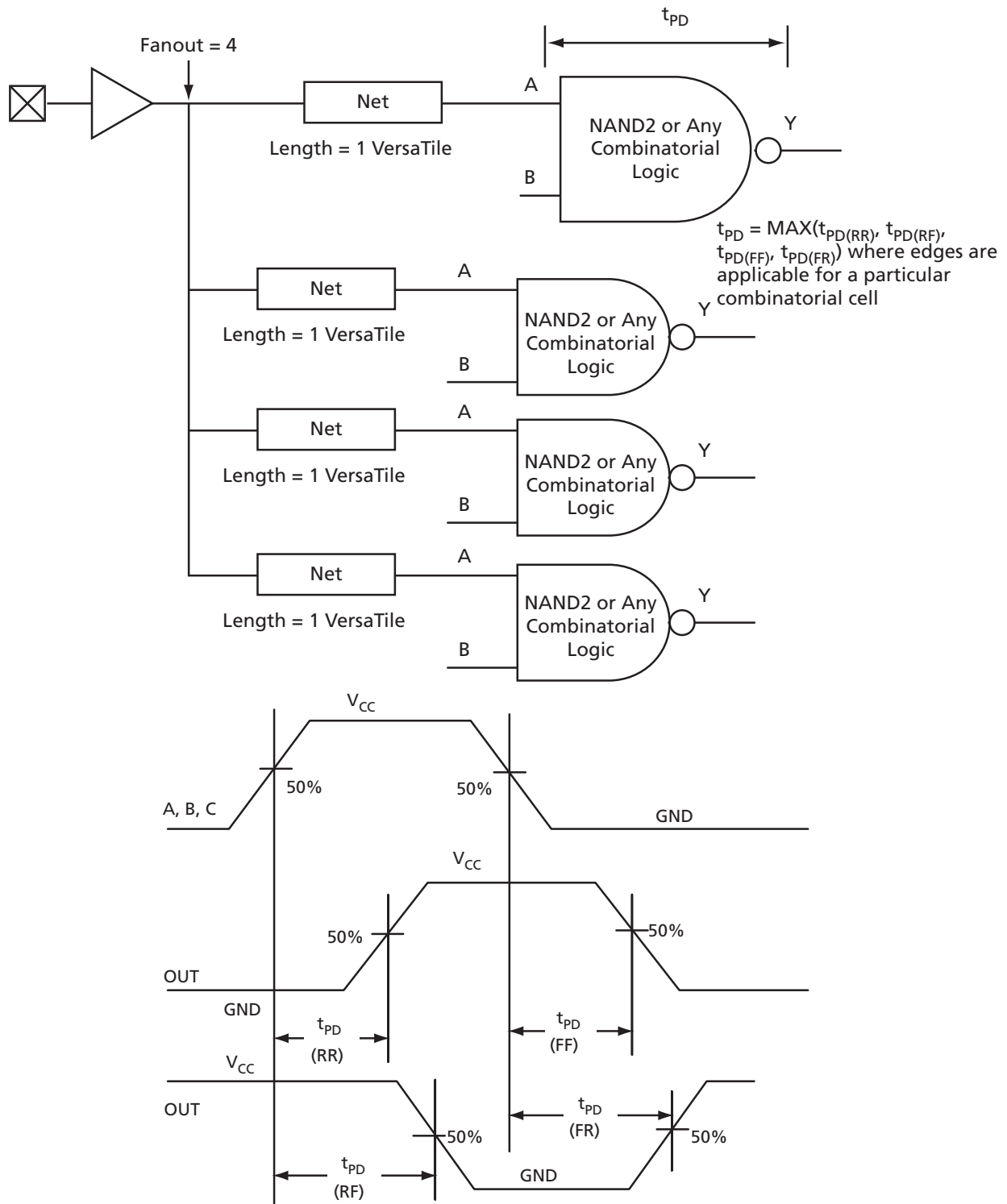

Figure 2-22 • Timing Model and Waveforms

Timing Characteristics

1.5 V DC Core Voltage

Table 2-85 • Combinatorial Cell Propagation Delays

Commercial-Case Conditions: $T_J = 70^\circ\text{C}$, Worst-Case $V_{CC} = 1.425\text{ V}$

Combinatorial Cell	Equation	Parameter	Std.	Units
INV	$Y = !A$	t_{PD}	0.76	ns
AND2	$Y = A \cdot B$	t_{PD}	0.87	ns
NAND2	$Y = !(A \cdot B)$	t_{PD}	0.91	ns
OR2	$Y = A + B$	t_{PD}	0.90	ns
NOR2	$Y = !(A + B)$	t_{PD}	0.94	ns
XOR2	$Y = A \oplus B$	t_{PD}	1.39	ns
MAJ3	$Y = \text{MAJ}(A, B, C)$	t_{PD}	1.44	ns
XOR3	$Y = A \oplus B \oplus C$	t_{PD}	1.60	ns
MUX2	$Y = A !S + B S$	t_{PD}	1.17	ns
AND3	$Y = A \cdot B \cdot C$	t_{PD}	1.18	ns

Note: For specific junction temperature and voltage supply levels, refer to [Table 2-6 on page 2-6](#) for derating values.

1.2 V DC Core Voltage

Table 2-86 • Combinatorial Cell Propagation Delays

Commercial-Case Conditions: $T_J = 70^\circ\text{C}$, Worst-Case $V_{CC} = 1.14\text{ V}$

Combinatorial Cell	Equation	Parameter	Std.	Units
INV	$Y = !A$	t_{PD}	1.33	ns
AND2	$Y = A \cdot B$	t_{PD}	1.48	ns
NAND2	$Y = !(A \cdot B)$	t_{PD}	1.58	ns
OR2	$Y = A + B$	t_{PD}	1.53	ns
NOR2	$Y = !(A + B)$	t_{PD}	1.63	ns
XOR2	$Y = A \oplus B$	t_{PD}	2.34	ns
MAJ3	$Y = \text{MAJ}(A, B, C)$	t_{PD}	2.59	ns
XOR3	$Y = A \oplus B \oplus C$	t_{PD}	2.74	ns
MUX2	$Y = A !S + B S$	t_{PD}	2.03	ns
AND3	$Y = A \cdot B \cdot C$	t_{PD}	2.11	ns

Note: For specific junction temperature and voltage supply levels, refer to [Table 2-7 on page 2-7](#) for derating values.

VersaTile Specifications as a Sequential Module

The IGLOO nano library offers a wide variety of sequential cells, including flip-flops and latches. Each has a data input and optional enable, clear, or preset. In this section, timing characteristics are presented for a representative sample from the library. For more details, refer to the *Fusion, IGLOO/e, and ProASIC3/E Macro Library Guide*.

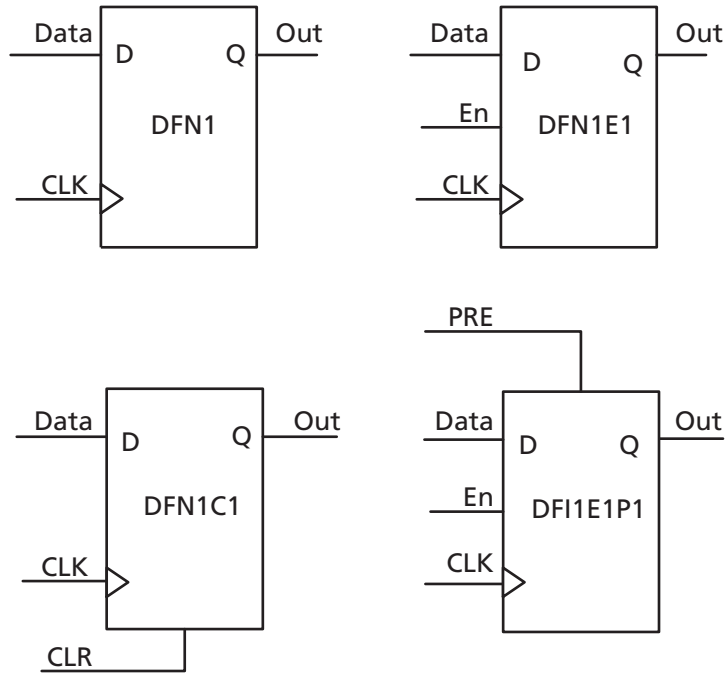
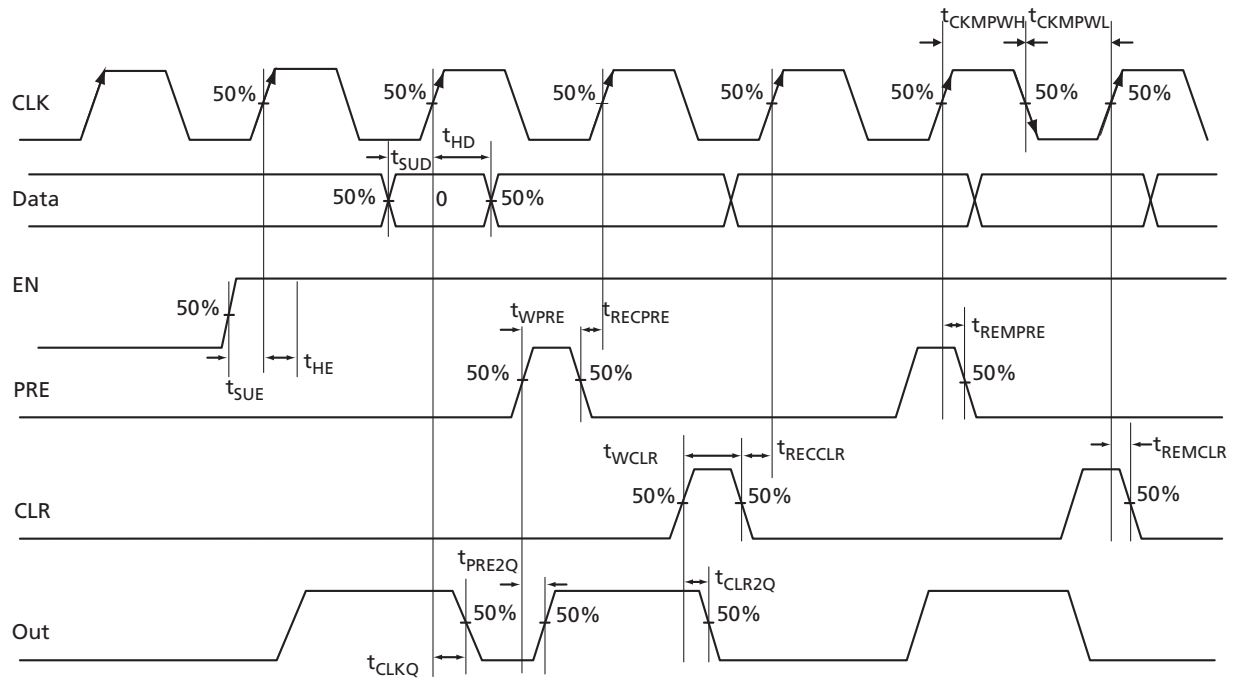

Figure 2-23 • Sample of Sequential Cells

Figure 2-24 • Timing Model and Waveforms

Timing Characteristics

1.5 V DC Core Voltage

Table 2-87 • Register Delays

 Commercial-Case Conditions: $T_J = 70^\circ\text{C}$, Worst-Case $V_{CC} = 1.425\text{ V}$

Parameter	Description	Std.	Units
t_{CLKQ}	Clock-to-Q of the Core Register	0.89	ns
t_{SUD}	Data Setup Time for the Core Register	0.81	ns
t_{HD}	Data Hold Time for the Core Register	0.00	ns
t_{SUE}	Enable Setup Time for the Core Register	0.73	ns
t_{HE}	Enable Hold Time for the Core Register	0.00	ns
t_{CLR2Q}	Asynchronous Clear-to-Q of the Core Register	0.60	ns
t_{PRE2Q}	Asynchronous Preset-to-Q of the Core Register	0.62	ns
t_{REMCLR}	Asynchronous Clear Removal Time for the Core Register	0.00	ns
t_{RECCLR}	Asynchronous Clear Recovery Time for the Core Register	0.24	ns
t_{REMPRE}	Asynchronous Preset Removal Time for the Core Register	0.00	ns
t_{RECPRE}	Asynchronous Preset Recovery Time for the Core Register	0.23	ns
t_{WCLR}	Asynchronous Clear Minimum Pulse Width for the Core Register	0.30	ns
t_{WPRE}	Asynchronous Preset Minimum Pulse Width for the Core Register	0.30	ns
t_{CKMPWH}	Clock Minimum Pulse Width HIGH for the Core Register	0.56	ns
t_{CKMPWL}	Clock Minimum Pulse Width LOW for the Core Register	0.56	ns

Note: For specific junction temperature and voltage supply levels, refer to [Table 2-6 on page 2-6](#) for derating values.

1.2 V DC Core Voltage

Table 2-88 • Register Delays

 Commercial-Case Conditions: $T_J = 70^\circ\text{C}$, Worst-Case $V_{CC} = 1.14\text{ V}$

Parameter	Description	Std.	Units
t_{CLKQ}	Clock-to-Q of the Core Register	1.61	ns
t_{SUD}	Data Setup Time for the Core Register	1.17	ns
t_{HD}	Data Hold Time for the Core Register	0.00	ns
t_{SUE}	Enable Setup Time for the Core Register	1.29	ns
t_{HE}	Enable Hold Time for the Core Register	0.00	ns
t_{CLR2Q}	Asynchronous Clear-to-Q of the Core Register	0.87	ns
t_{PRE2Q}	Asynchronous Preset-to-Q of the Core Register	0.89	ns
t_{REMCLR}	Asynchronous Clear Removal Time for the Core Register	0.00	ns
t_{RECCLR}	Asynchronous Clear Recovery Time for the Core Register	0.24	ns
t_{REMPRE}	Asynchronous Preset Removal Time for the Core Register	0.00	ns
t_{RECPRE}	Asynchronous Preset Recovery Time for the Core Register	0.24	ns
t_{WCLR}	Asynchronous Clear Minimum Pulse Width for the Core Register	0.46	ns
t_{WPRE}	Asynchronous Preset Minimum Pulse Width for the Core Register	0.46	ns
t_{CKMPWH}	Clock Minimum Pulse Width HIGH for the Core Register	0.95	ns
t_{CKMPWL}	Clock Minimum Pulse Width LOW for the Core Register	0.95	ns

Note: For specific junction temperature and voltage supply levels, refer to [Table 2-7 on page 2-7](#) for derating values.

Global Resource Characteristics

AGLN125 Clock Tree Topology

Clock delays are device-specific. Figure 2-25 is an example of a global tree used for clock routing. The global tree presented in Figure 2-25 is driven by a CCC located on the west side of the AGLN125 device. It is used to drive all D-flip-flops in the device.

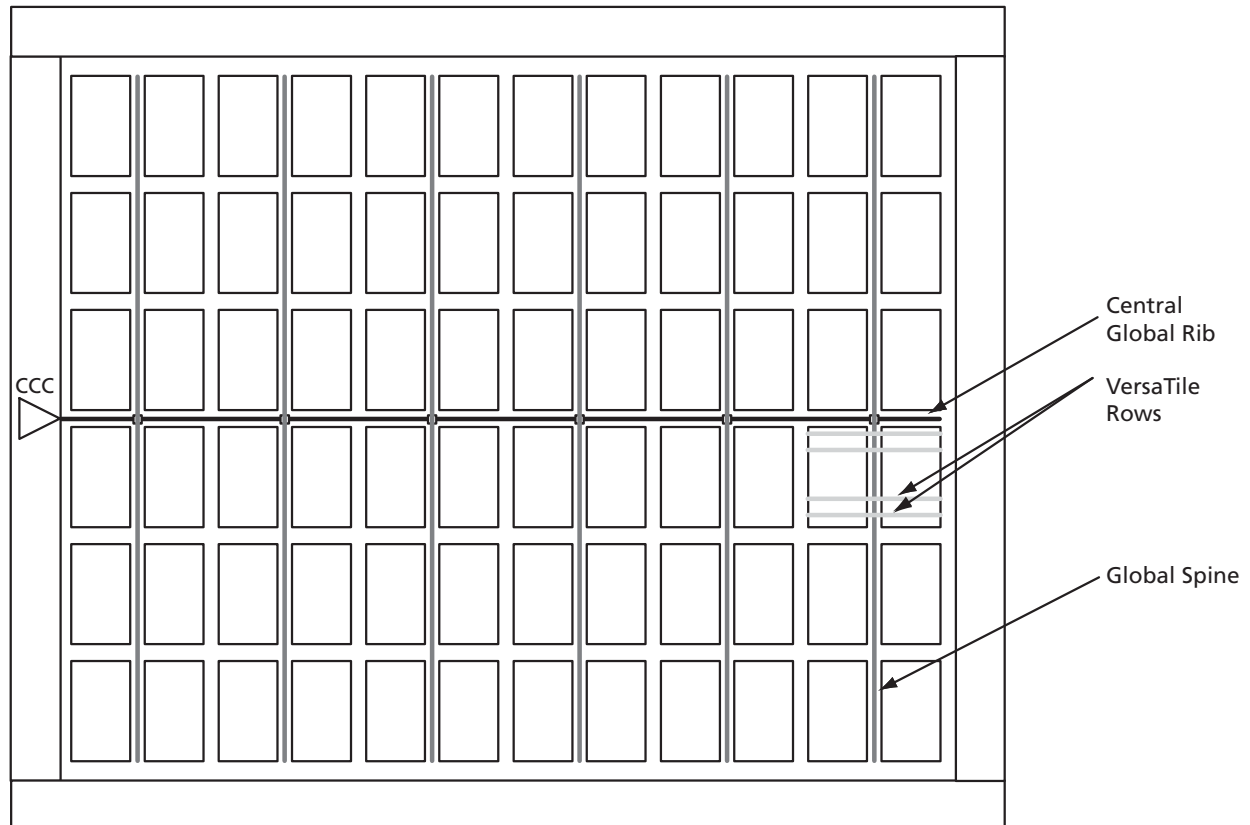

Figure 2-25 • Example of Global Tree Use in an AGLN125 Device for Clock Routing

Global Tree Timing Characteristics

Global clock delays include the central rib delay, the spine delay, and the row delay. Delays do not include I/O input buffer clock delays, as these are I/O standard-dependent, and the clock may be driven and conditioned internally by the CCC module. For more details on clock conditioning capabilities, refer to the "Clock Conditioning Circuits" section on page 2-70. Table 2-89 to Table 2-97 on page 2-68 present minimum and maximum global clock delays within each device. Minimum and maximum delays are measured with minimum and maximum loading.

Timing Characteristics

1.5 V DC Core Voltage

Table 2-89 • AGLN010 Global Resource
Commercial-Case Conditions: $T_J = 70^\circ\text{C}$, $V_{CC} = 1.425\text{ V}$

Parameter	Description	Std.		Units
		Min. ¹	Max. ²	
t_{RCKL}	Input Low Delay for Global Clock	1.13	1.42	ns
t_{RCKH}	Input High Delay for Global Clock	1.15	1.50	ns
$t_{RCKMPWH}$	Minimum Pulse Width HIGH for Global Clock			ns
$t_{RCKMPWL}$	Minimum Pulse Width LOW for Global Clock			ns
t_{RCKSW}	Maximum Skew for Global Clock		0.35	ns
F_{RMAX}	Maximum Frequency for Global Clock			MHz

Notes:

1. Value reflects minimum load. The delay is measured from the CCC output to the clock pin of a sequential element, located in a lightly loaded row (single element is connected to the global net).
2. Value reflects maximum load. The delay is measured on the clock pin of the farthest sequential element, located in a fully loaded row (all available flip-flops are connected to the global net in the row).
3. For specific junction temperature and voltage supply levels, refer to Table 2-6 on page 2-6 for derating values.

Table 2-90 • AGLN015 Global Resource
Commercial-Case Conditions: $T_J = 70^\circ\text{C}$, $V_{CC} = 1.425\text{ V}$

Parameter	Description	Std.		Units
		Min. ¹	Max. ²	
t_{RCKL}	Input Low Delay for Global Clock	1.21	1.55	ns
t_{RCKH}	Input High Delay for Global Clock	1.23	1.65	ns
$t_{RCKMPWH}$	Minimum Pulse Width HIGH for Global Clock			ns
$t_{RCKMPWL}$	Minimum Pulse Width LOW for Global Clock			ns
t_{RCKSW}	Maximum Skew for Global Clock		0.42	ns
F_{RMAX}	Maximum Frequency for Global Clock			MHz

Notes:

1. Value reflects minimum load. The delay is measured from the CCC output to the clock pin of a sequential element, located in a lightly loaded row (single element is connected to the global net).
2. Value reflects maximum load. The delay is measured on the clock pin of the farthest sequential element, located in a fully loaded row (all available flip-flops are connected to the global net in the row).
3. For specific junction temperature and voltage supply levels, refer to Table 2-6 on page 2-6 for derating values.

Table 2-91 • AGLN020 Global Resource
Commercial-Case Conditions: $T_J = 70^\circ\text{C}$, $V_{CC} = 1.425\text{ V}$

Parameter	Description	Std.		Units
		Min. ¹	Max. ²	
t_{RCKL}	Input Low Delay for Global Clock	1.21	1.55	ns
t_{RCKH}	Input High Delay for Global Clock	1.23	1.65	ns
$t_{RCKMPWH}$	Minimum Pulse Width High for Global Clock			ns
$t_{RCKMPWL}$	Minimum Pulse Width Low for Global Clock			ns
t_{RCKSW}	Maximum Skew for Global Clock		0.42	ns
F_{RMAX}	Maximum Frequency for Global Clock			MHz

Notes:

1. Value reflects minimum load. The delay is measured from the CCC output to the clock pin of a sequential element, located in a lightly loaded row (single element is connected to the global net).
2. Value reflects maximum load. The delay is measured on the clock pin of the farthest sequential element, located in a fully loaded row (all available flip-flops are connected to the global net in the row).
3. For specific junction temperature and voltage supply levels, refer to [Table 2-6 on page 2-6](#) for derating values.

Table 2-92 • AGLN060 Global Resource
Commercial-Case Conditions: $T_J = 70^\circ\text{C}$, $V_{CC} = 1.425\text{ V}$

Parameter	Description	Std.		Units
		Min. ¹	Max. ²	
t_{RCKL}	Input Low Delay for Global Clock	1.32	1.62	ns
t_{RCKH}	Input High Delay for Global Clock	1.34	1.71	ns
$t_{RCKMPWH}$	Minimum Pulse Width HIGH for Global Clock			ns
$t_{RCKMPWL}$	Minimum Pulse Width LOW for Global Clock			ns
t_{RCKSW}	Maximum Skew for Global Clock		0.38	ns
F_{RMAX}	Maximum Frequency for Global Clock			MHz

Notes:

1. Value reflects minimum load. The delay is measured from the CCC output to the clock pin of a sequential element, located in a lightly loaded row (single element is connected to the global net).
2. Value reflects maximum load. The delay is measured on the clock pin of the farthest sequential element, located in a fully loaded row (all available flip-flops are connected to the global net in the row).
3. For specific junction temperature and voltage supply levels, refer to [Table 2-6 on page 2-6](#) for derating values.

Table 2-93 • AGLN125 Global Resource
Commercial-Case Conditions: $T_J = 70^\circ\text{C}$, $V_{CC} = 1.425\text{ V}$

Parameter	Description	Std.		Units
		Min. ¹	Max. ²	
t_{RCKL}	Input Low Delay for Global Clock	1.36	1.71	ns
t_{RCKH}	Input High Delay for Global Clock	1.39	1.82	ns
$t_{RCKMPWH}$	Minimum Pulse Width High for Global Clock			ns
$t_{RCKMPWL}$	Minimum Pulse Width Low for Global Clock			ns
t_{RCKSW}	Maximum Skew for Global Clock		0.43	ns
F_{RMAX}	Maximum Frequency for Global Clock			MHz

Notes:

1. Value reflects minimum load. The delay is measured from the CCC output to the clock pin of a sequential element, located in a lightly loaded row (single element is connected to the global net).
2. Value reflects maximum load. The delay is measured on the clock pin of the farthest sequential element, located in a fully loaded row (all available flip-flops are connected to the global net in the row).
3. For specific junction temperature and voltage supply levels, refer to [Table 2-6 on page 2-6](#) for derating values.

Table 2-94 • AGLN250 Global Resource
Commercial-Case Conditions: $T_J = 70^\circ\text{C}$, $V_{CC} = 1.425\text{ V}$

Parameter	Description	Std.		Units
		Min. ¹	Max. ²	
t_{RCKL}	Input Low Delay for Global Clock	1.39	1.73	ns
t_{RCKH}	Input High Delay for Global Clock	1.41	1.84	ns
$t_{RCKMPWH}$	Minimum Pulse Width High for Global Clock			ns
$t_{RCKMPWL}$	Minimum Pulse Width Low for Global Clock			ns
t_{RCKSW}	Maximum Skew for Global Clock		0.43	ns
F_{RMAX}	Maximum Frequency for Global Clock			MHz

Notes:

1. Value reflects minimum load. The delay is measured from the CCC output to the clock pin of a sequential element, located in a lightly loaded row (single element is connected to the global net).
2. Value reflects maximum load. The delay is measured on the clock pin of the farthest sequential element, located in a fully loaded row (all available flip-flops are connected to the global net in the row).
3. For specific junction temperature and voltage supply levels, refer to [Table 2-6 on page 2-6](#) for derating values.

1.2 V DC Core Voltage

Table 2-95 • AGLN010 Global Resource
Commercial-Case Conditions: $T_J = 70^\circ\text{C}$, $V_{CC} = 1.14\text{ V}$

Parameter	Description	Std.		Units
		Min. ¹	Max. ²	
t_{RCKL}	Input Low Delay for Global Clock	1.71	2.09	ns
t_{RCKH}	Input High Delay for Global Clock	1.78	2.31	ns
$t_{RCKMPWH}$	Minimum Pulse Width High for Global Clock			ns
$t_{RCKMPWL}$	Minimum Pulse Width Low for Global Clock			ns
t_{RCKSW}	Maximum Skew for Global Clock		0.53	ns
F_{RMAX}	Maximum Frequency for Global Clock			MHz

Notes:

1. Value reflects minimum load. The delay is measured from the CCC output to the clock pin of a sequential element, located in a lightly loaded row (single element is connected to the global net).
2. Value reflects maximum load. The delay is measured on the clock pin of the farthest sequential element, located in a fully loaded row (all available flip-flops are connected to the global net in the row).
3. For specific junction temperature and voltage supply levels, refer to [Table 2-7 on page 2-7](#) for derating values.

Table 2-96 • AGLN015 Global Resource
Commercial-Case Conditions: $T_J = 70^\circ\text{C}$, $V_{CC} = 1.14\text{ V}$

Parameter	Description	Std.		Units
		Min. ¹	Max. ²	
t_{RCKL}	Input Low Delay for Global Clock	1.81	2.26	ns
t_{RCKH}	Input High Delay for Global Clock	1.90	2.51	ns
$t_{RCKMPWH}$	Minimum Pulse Width High for Global Clock			ns
$t_{RCKMPWL}$	Minimum Pulse Width Low for Global Clock			ns
t_{RCKSW}	Maximum Skew for Global Clock		0.61	ns
F_{RMAX}	Maximum Frequency for Global Clock			MHz

Notes:

1. Value reflects minimum load. The delay is measured from the CCC output to the clock pin of a sequential element, located in a lightly loaded row (single element is connected to the global net).
2. Value reflects maximum load. The delay is measured on the clock pin of the farthest sequential element, located in a fully loaded row (all available flip-flops are connected to the global net in the row).
3. For specific junction temperature and voltage supply levels, refer to [Table 2-7 on page 2-7](#) for derating values.

Table 2-97 • AGLN020 Global Resource
Commercial-Case Conditions: $T_J = 70^\circ\text{C}$, $V_{CC} = 1.14\text{ V}$

Parameter	Description	Std.		Units
		Min. ¹	Max. ²	
t_{RCKL}	Input Low Delay for Global Clock	1.81	2.26	ns
t_{RCKH}	Input High Delay for Global Clock	1.90	2.51	ns
$t_{RCKMPWH}$	Minimum Pulse Width High for Global Clock			ns
$t_{RCKMPWL}$	Minimum Pulse Width Low for Global Clock			ns
t_{RCKSW}	Maximum Skew for Global Clock		0.61	ns
F_{RMAX}	Maximum Frequency for Global Clock			MHz

Notes:

1. Value reflects minimum load. The delay is measured from the CCC output to the clock pin of a sequential element, located in a lightly loaded row (single element is connected to the global net).
2. Value reflects maximum load. The delay is measured on the clock pin of the farthest sequential element, located in a fully loaded row (all available flip-flops are connected to the global net in the row).
3. For specific junction temperature and voltage supply levels, refer to [Table 2-7 on page 2-7](#) for derating values.

Table 2-98 • AGLN060 Global Resource
Commercial-Case Conditions: $T_J = 70^\circ\text{C}$, $V_{CC} = 1.14\text{ V}$

Parameter	Description	Std.		Units
		Min. ¹	Max. ²	
t_{RCKL}	Input Low Delay for Global Clock	2.02	2.42	ns
t_{RCKH}	Input High Delay for Global Clock	2.09	2.65	ns
$t_{RCKMPWH}$	Minimum Pulse Width High for Global Clock			ns
$t_{RCKMPWL}$	Minimum Pulse Width Low for Global Clock			ns
t_{RCKSW}	Maximum Skew for Global Clock		0.56	ns
F_{RMAX}	Maximum Frequency for Global Clock			MHz

Notes:

1. Value reflects minimum load. The delay is measured from the CCC output to the clock pin of a sequential element, located in a lightly loaded row (single element is connected to the global net).
2. Value reflects maximum load. The delay is measured on the clock pin of the farthest sequential element, located in a fully loaded row (all available flip-flops are connected to the global net in the row).
3. For specific junction temperature and voltage supply levels, refer to [Table 2-7 on page 2-7](#) for derating values.

Table 2-99 • AGLN125 Global Resource
Commercial-Case Conditions: $T_J = 70^\circ\text{C}$, $V_{CC} = 1.14\text{ V}$

Parameter	Description	Std.		Units
		Min. ¹	Max. ²	
t_{RCKL}	Input Low Delay for Global Clock	2.08	2.54	ns
t_{RCKH}	Input High Delay for Global Clock	2.15	2.77	ns
$t_{RCKMPWH}$	Minimum Pulse Width HIGH for Global Clock			ns
$t_{RCKMPWL}$	Minimum Pulse Width LOW for Global Clock			ns
t_{RCKSW}	Maximum Skew for Global Clock		0.62	ns
F_{RMAX}	Maximum Frequency for Global Clock			MHz

Notes:

1. Value reflects minimum load. The delay is measured from the CCC output to the clock pin of a sequential element, located in a lightly loaded row (single element is connected to the global net).
2. Value reflects maximum load. The delay is measured on the clock pin of the farthest sequential element, located in a fully loaded row (all available flip-flops are connected to the global net in the row).
3. For specific junction temperature and voltage supply levels, refer to [Table 2-7 on page 2-7](#) for derating values.

Table 2-100 • AGLN250 Global Resource
Commercial-Case Conditions: $T_J = 70^\circ\text{C}$, $V_{CC} = 1.14\text{ V}$

Parameter	Description	Std.		Units
		Min. ¹	Max. ²	
t_{RCKL}	Input Low Delay for Global Clock	2.11	2.57	ns
t_{RCKH}	Input High Delay for Global Clock	2.19	2.81	ns
$t_{RCKMPWH}$	Minimum Pulse Width High for Global Clock			ns
$t_{RCKMPWL}$	Minimum Pulse Width Low for Global Clock			ns
t_{RCKSW}	Maximum Skew for Global Clock		0.62	ns
F_{RMAX}	Maximum Frequency for Global Clock			MHz

Notes:

1. Value reflects minimum load. The delay is measured from the CCC output to the clock pin of a sequential element, located in a lightly loaded row (single element is connected to the global net).
2. Value reflects maximum load. The delay is measured on the clock pin of the farthest sequential element, located in a fully loaded row (all available flip-flops are connected to the global net in the row).
3. For specific junction temperature and voltage supply levels, refer to [Table 2-7 on page 2-7](#) for derating values.

Table 2-102 • IGL00 nano CCC/PLL Specification
For IGL00 nano V2 Devices, 1.2 V DC Core Supply Voltage

Parameter	Min.	Typ.	Max.	Units	
Clock Conditioning Circuitry Input Frequency f_{IN_CCC}	1.5		160	MHz	
Clock Conditioning Circuitry Output Frequency f_{OUT_CCC}	0.75		160	MHz	
Delay Increments in Programmable Delay Blocks ^{1, 2}		580		ps	
Number of Programmable Values in Each Programmable Delay Block			32		
Serial Clock (SCLK) for Dynamic PLL ³			60		
Input Cycle-to-Cycle Jitter (peak magnitude)			0.25	ns	
Acquisition Time					
					LockControl = 0
Tracking Jitter ⁴					
					LockControl = 0
Output Duty Cycle	48.5		51.5	%	
Delay Range in Block: Programmable Delay 1 ^{1, 2}	2.3		20.86	ns	
Delay Range in Block: Programmable Delay 2 ^{1, 2}	0.025		20.86	ns	
Delay Range in Block: Fixed Delay ^{1, 2}		5.7		ns	
VCO Output Peak-to-Peak Period Jitter F_{CCC_OUT} ⁵	Max Peak-to-Peak Period Jitter ^{5,6,7}				
	SSO ≤ 2	SSO ≤ 4	SSO ≤ 8	SSO ≤ 16	
0.75 MHz to 50MHz	0.50	1.20	2.00	3.00	%
50 MHz to 100 MHz	2.50	5.00	7.00	15.00	%

Notes:

1. This delay is a function of voltage and temperature. See [Table 2-6 on page 2-6](#) and [Table 2-7 on page 2-7](#) for deratings.
2. $T_J = 25^\circ\text{C}$, $V_{CC} = 1.2\text{ V}$
3. Maximum value obtained for a STD speed grade device in Worst-Case Commercial conditions. For specific junction temperature and voltage supply levels, refer to [Table 2-6 on page 2-6](#) and [Table 2-7 on page 2-7](#) for derating values.
4. Tracking jitter is defined as the variation in clock edge position of PLL outputs with reference to the PLL input clock edge. Tracking jitter does not measure the variation in PLL output period, which is covered by the period jitter parameter.
5. VCO output jitter is calculated as a percentage of the VCO frequency. The jitter (in ps) can be calculated by multiplying the VCO period by the % jitter. The VCO jitter (in ps) applies to CCC_OUT, regardless of the output divider settings. For example, if the jitter on VCO is 300 ps, the jitter on CCC_OUT is also 300 ps, no matter what the settings are for the output divider.
6. Measurements done with LVTTTL 3.3 V 8 mA I/O drive strength and high slew rate. $V_{CC}/V_{CCPLL} = 1.14\text{ V}$, $V_{CCI} = 3.3\text{ V}$, VQ/PQ/TQ type of packages, 20 pF load.
7. SSOs are outputs that are synchronous to a single clock domain and have their clock-to-out times within $\pm 200\text{ ps}$ of each other. Switching I/Os are placed outside of the PLL bank. Refer to [ProASIC3/E SSO and Pin Placement Guidelines](#).
8. The AGLN010, AGLN015, and AGLN020 devices do not support PLLs.

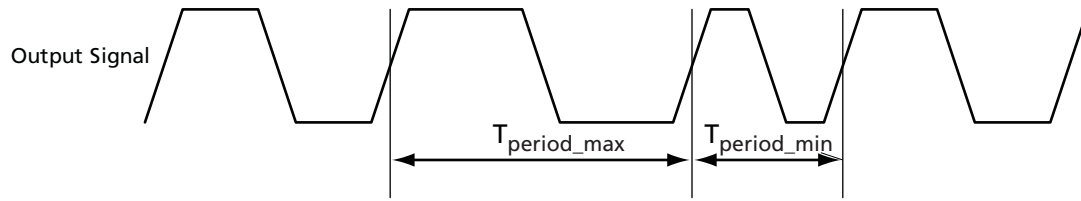

Note: Peak-to-peak jitter measurements are defined by $T_{\text{peak-to-peak}} = T_{\text{period_max}} - T_{\text{period_min}}$.

Figure 2-26 • Peak-to-Peak Jitter Definition

Embedded SRAM and FIFO Characteristics

SRAM

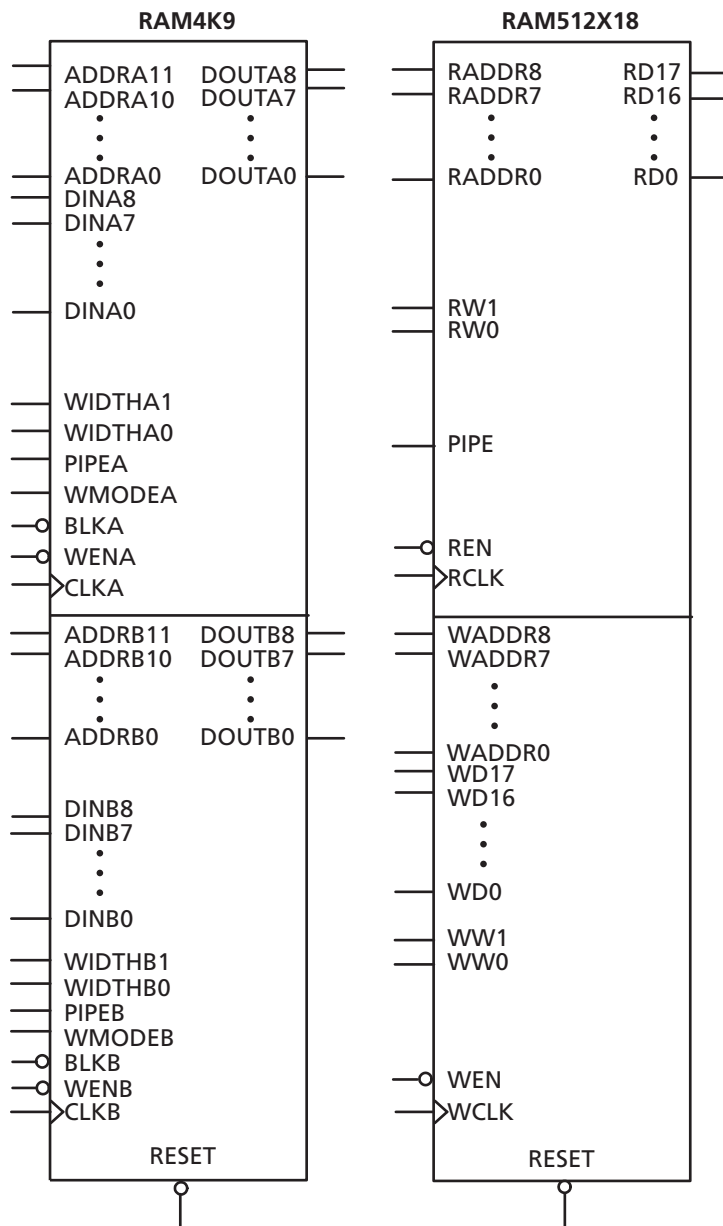

Figure 2-27 • RAM Models

Timing Waveforms

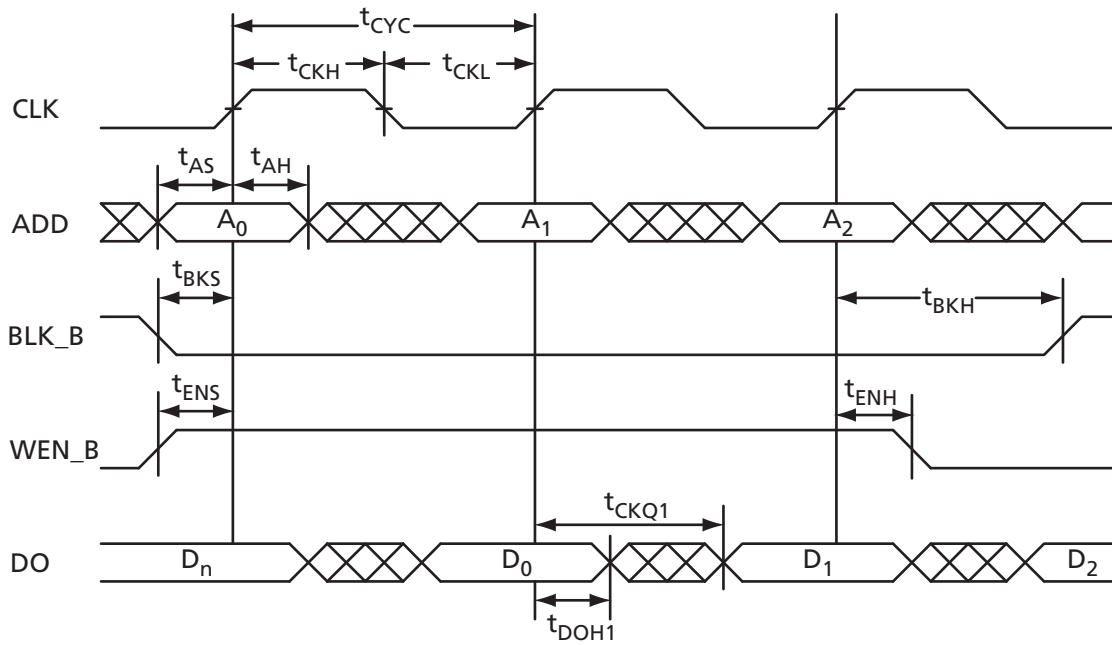

Figure 2-28 • RAM Read for Pass-Through Output

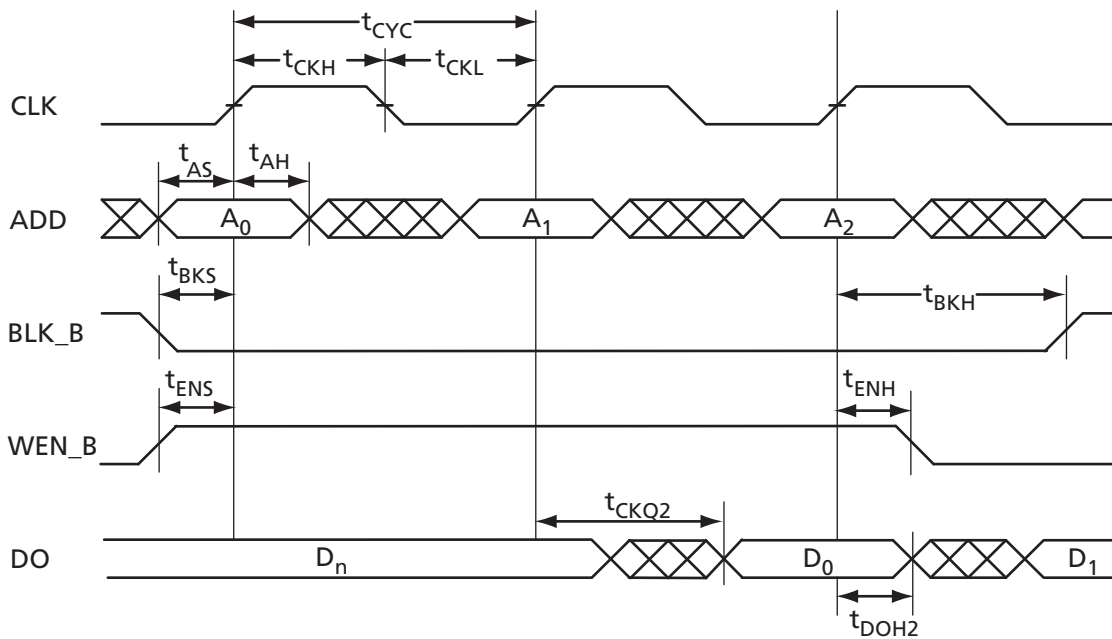

Figure 2-29 • RAM Read for Pipelined Output

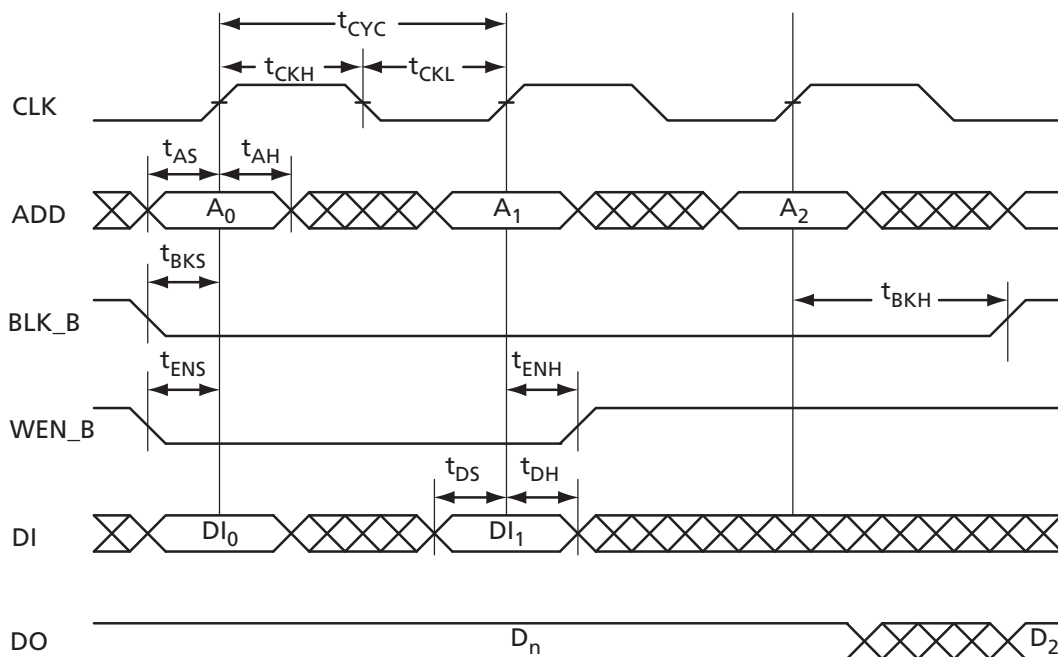

Figure 2-30 • RAM Write, Output Retained (WMODE = 0)

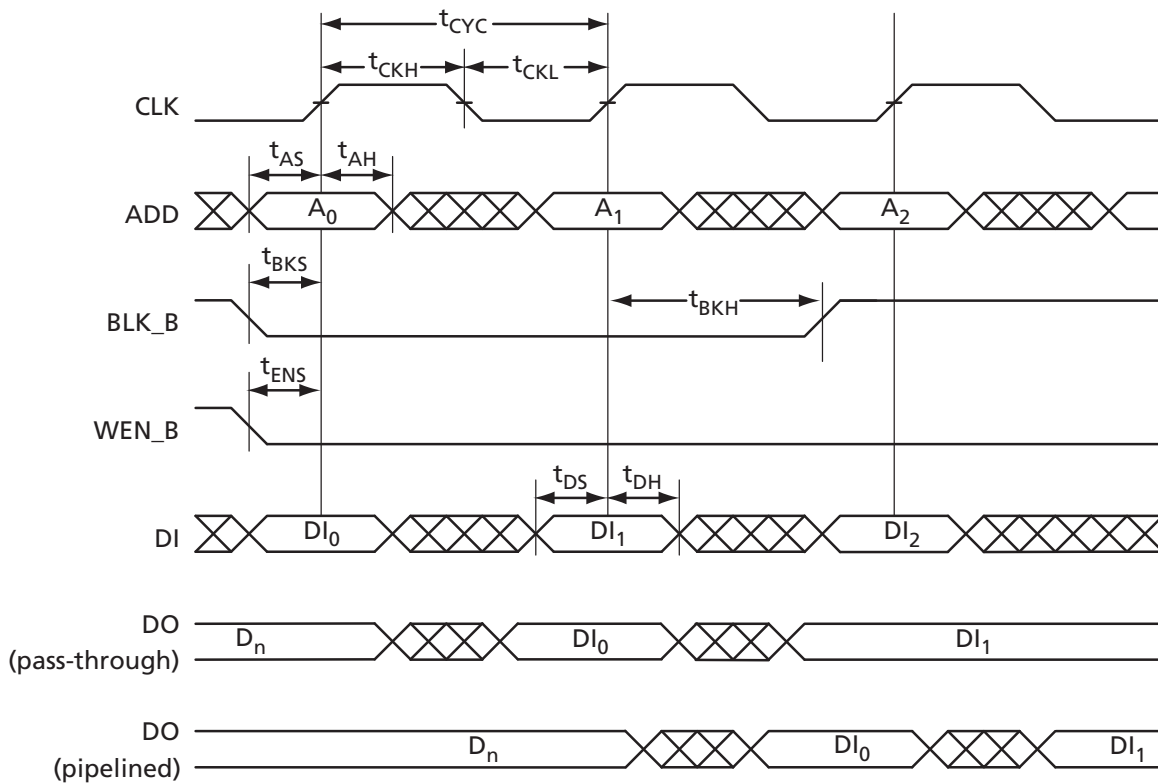
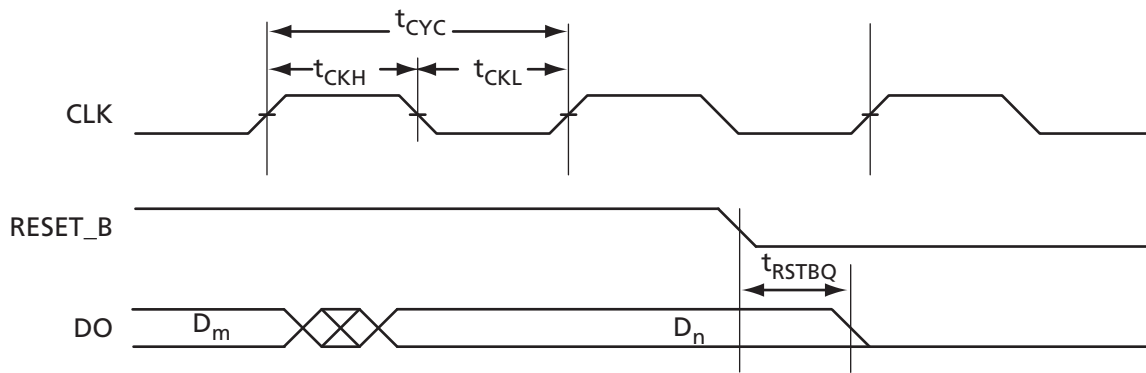

Figure 2-31 • RAM Write, Output as Write Data (WMODE = 1)

**Figure 2-32 • RAM Reset**

Timing Characteristics

1.5 V DC Core Voltage

Table 2-103 • RAM4K9
Commercial-Case Conditions: $T_J = 70^\circ\text{C}$, Worst-Case $V_{CC} = 1.425\text{ V}$

Parameter	Description	Std.	Units
t_{AS}	Address setup time	0.69	ns
t_{AH}	Address hold time	0.13	ns
t_{ENS}	REN_B, WEN_B setup time	0.68	ns
t_{ENH}	REN_B, WEN_B hold time	0.13	ns
t_{BKS}	BLK_B setup time	1.37	ns
t_{BKH}	BLK_B hold time	0.13	ns
t_{DS}	Input data (DI) setup time	0.59	ns
t_{DH}	Input data (DI) hold time	0.30	ns
t_{CKQ1}	Clock HIGH to new data valid on DO (output retained, WMODE = 0)	2.94	ns
	Clock HIGH to new data valid on DO (flow-through, WMODE = 1)	2.55	ns
t_{CKQ2}	Clock HIGH to new data valid on DO (pipelined)	1.51	ns
t_{C2CWWL}	Address collision clk-to-clk delay for reliable write after write on same address; applicable to closing edge	0.23	ns
t_{C2CRWH}	Address collision clk-to-clk delay for reliable read access after write on same address; applicable to opening edge	0.35	ns
t_{C2CWRH}	Address collision clk-to-clk delay for reliable write access after read on same address; applicable to opening edge	0.41	ns
t_{RSTBQ}	RESET_B LOW to data out LOW on DO (flow-through)	1.72	ns
	RESET_B LOW to data out LOW on DO (pipelined)	1.72	ns
$t_{REMRSTB}$	RESET_B removal	0.51	ns
$t_{RECRSTB}$	RESET_B recovery	2.68	ns
$t_{MPWRSTB}$	RESET_B minimum pulse width	0.68	ns
t_{CYC}	Clock cycle time	6.24	ns
F_{MAX}	Maximum frequency	160	MHz

Note: For specific junction temperature and voltage supply levels, refer to [Table 2-6 on page 2-6](#) for derating values.

Table 2-104 • RAM512X18
Commercial-Case Conditions: $T_J = 70^\circ\text{C}$, Worst-Case $V_{CC} = 1.425\text{ V}$

Parameter	Description	Std.	Units
t_{AS}	Address setup time	0.69	ns
t_{AH}	Address hold time	0.13	ns
t_{ENS}	REN_B, WEN_B setup time	0.61	ns
t_{ENH}	REN_B, WEN_B hold time	0.07	ns
t_{DS}	Input data (DI) setup time	0.59	ns
t_{DH}	Input data (DI) hold time	0.30	ns
t_{CKQ1}	Clock HIGH to new data valid on DO (output retained, WMODE = 0)	3.51	ns
t_{CKQ2}	Clock HIGH to new data valid on DO (pipelined)	1.43	ns
t_{C2CRWH}	Address collision clk-to-clk delay for reliable read access after write on same address; applicable to opening edge	0.35	ns
t_{C2CWRH}	Address collision clk-to-clk delay for reliable write access after read on same address; applicable to opening edge	0.42	ns
t_{RSTBQ}	RESET_B LOW to data out LOW on DO (flow-through)	1.72	ns
	RESET_B LOW to data out LOW on DO (pipelined)	1.72	ns
$t_{REMRSTB}$	RESET_B removal	0.51	0.51
$t_{RECRSTB}$	RESET_B recovery	2.68	ns
$t_{MPWRSTB}$	RESET_B minimum pulse width	0.68	ns
t_{CYC}	Clock cycle time	6.24	ns
F_{MAX}	Maximum frequency	160	MHz

Note: For specific junction temperature and voltage supply levels, refer to [Table 2-6 on page 2-6](#) for derating values.

1.2 V DC Core Voltage

Table 2-105 • RAM4K9

Commercial-Case Conditions: $T_J = 70^\circ\text{C}$, Worst-Case $V_{CC} = 1.14\text{ V}$

Parameter	Description	Std.	Units
t_{AS}	Address setup time	1.28	ns
t_{AH}	Address hold time	0.25	ns
t_{ENS}	REN_B, WEN_B setup time	1.25	ns
t_{ENH}	REN_B, WEN_B hold time	0.25	ns
t_{BKS}	BLK_B setup time	2.54	ns
t_{BKH}	BLK_B hold time	0.25	ns
t_{DS}	Input data (DI) setup time	1.10	ns
t_{DH}	Input data (DI) hold time	0.55	ns
t_{CKQ1}	Clock HIGH to new data valid on DO (output retained, WMODE = 0)	5.51	ns
	Clock HIGH to new data valid on DO (flow-through, WMODE = 1)	4.77	ns
t_{CKQ2}	Clock HIGH to new data valid on DO (pipelined)	2.82	ns
t_{C2CWWL}	Address collision clk-to-clk delay for reliable write after write on same address; applicable to closing edge	0.30	ns
t_{C2CRWH}	Address collision clk-to-clk delay for reliable read access after write on same address; applicable to opening edge	0.89	ns
t_{C2CWRH}	Address collision clk-to-clk delay for reliable write access after read on same address; applicable to opening edge	1.01	ns
t_{RSTBQ}	RESET_B LOW to data out LOW on DO (flow-through)	3.21	ns
	RESET_B LOW to data out LOW on DO (pipelined)	3.21	ns
$t_{REMRSTB}$	RESET_B removal	0.93	ns
$t_{RECRSTB}$	RESET_B recovery	4.94	ns
$t_{MPWRSTB}$	RESET_B minimum pulse width	1.18	ns
t_{CYC}	Clock cycle time	10.90	ns
F_{MAX}	Maximum frequency	92	MHz

Note: For specific junction temperature and voltage supply levels, refer to [Table 2-7 on page 2-7](#) for derating values.

Table 2-106 • RAM512X18
Commercial-Case Conditions: $T_J = 70^\circ\text{C}$, Worst-Case $V_{CC} = 1.14\text{ V}$

Parameter	Description	Std.	Units
t_{AS}	Address setup time	1.28	ns
t_{AH}	Address hold time	0.25	ns
t_{ENS}	REN_B, WEN_B setup time	1.13	ns
t_{ENH}	REN_B, WEN_B hold time	0.13	ns
t_{DS}	Input data (DI) setup time	1.10	ns
t_{DH}	Input data (DI) hold time	0.55	ns
t_{CKQ1}	Clock HIGH to new data valid on DO (output retained, WMODE = 0)	6.56	ns
t_{CKQ2}	Clock HIGH to new data valid on DO (pipelined)	2.67	ns
t_{C2CRWH}	Address collision clk-to-clk delay for reliable read access after write on same address; applicable to opening edge	0.87	ns
t_{C2CWRH}	Address collision clk-to-clk delay for reliable write access after read on same address; applicable to opening edge	1.04	ns
t_{RSTBQ}	RESET_B LOW to data out LOW on DO (flow through)	3.21	ns
	RESET_B LOW to data out LOW on DO (pipelined)	3.21	ns
$t_{REMRSTB}$	RESET_B removal	0.93	ns
$t_{RECRSTB}$	RESET_B recovery	4.94	ns
$t_{MPWRSTB}$	RESET_B minimum pulse width	1.18	ns
t_{CYC}	Clock cycle time	10.90	ns
F_{MAX}	Maximum frequency	92	MHz

Note: For specific junction temperature and voltage supply levels, refer to [Table 2-7 on page 2-7](#) for derating values.

FIFO

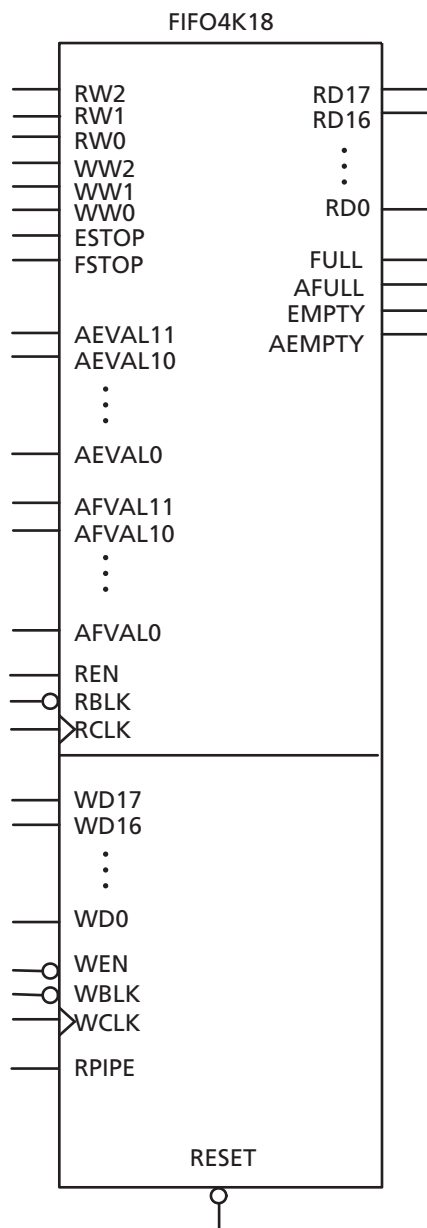

Figure 2-33 • FIFO Model

Timing Waveforms

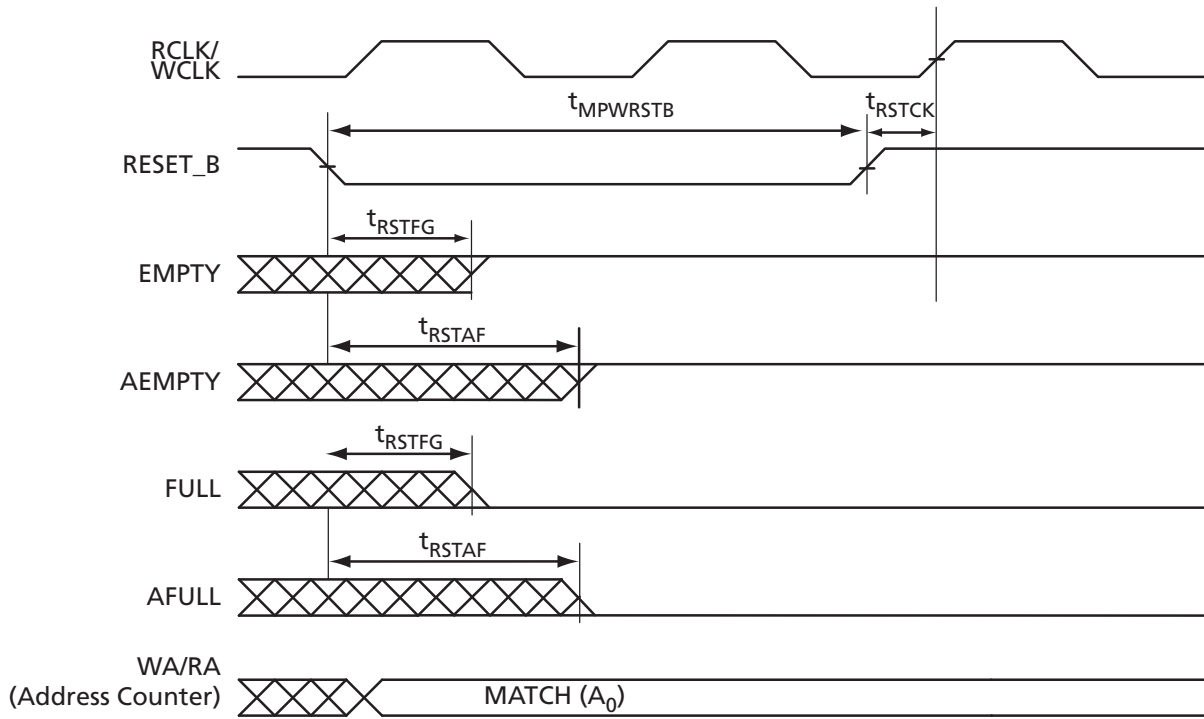

Figure 2-34 • FIFO Reset

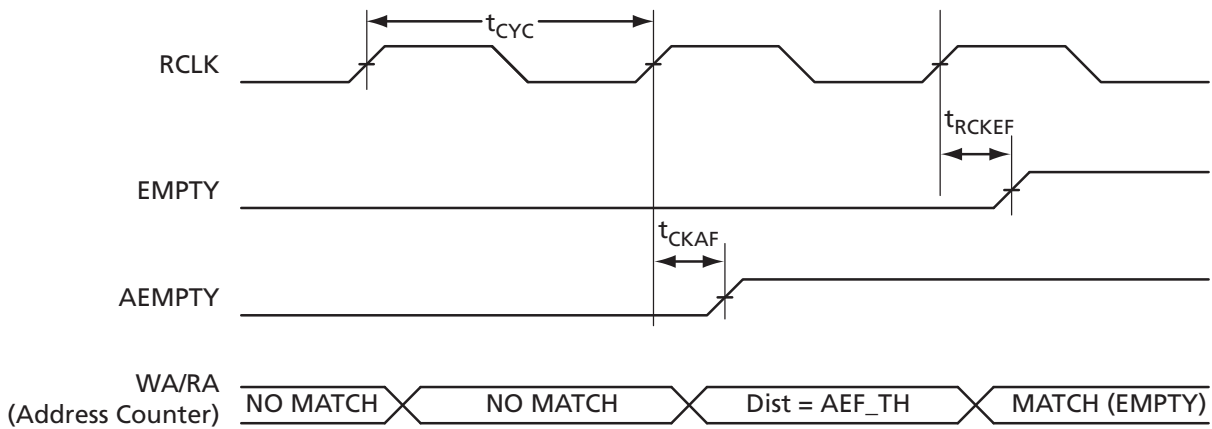
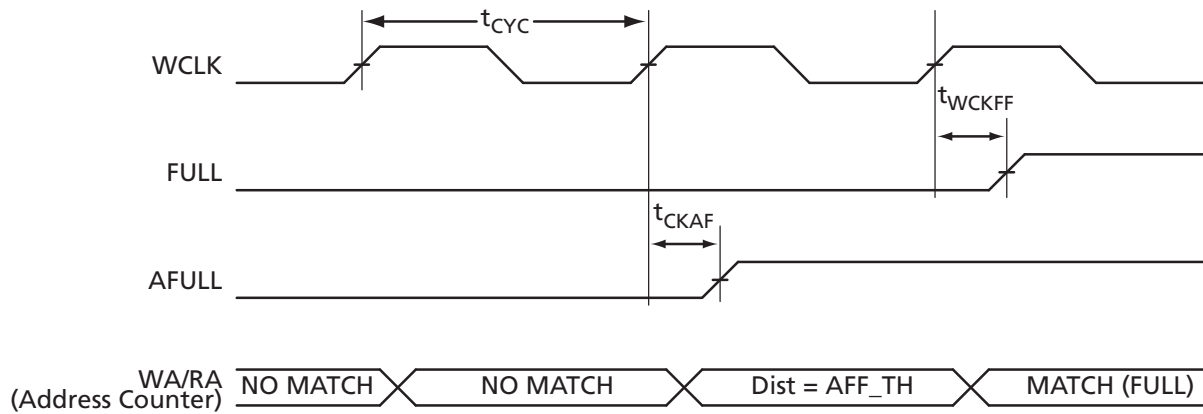
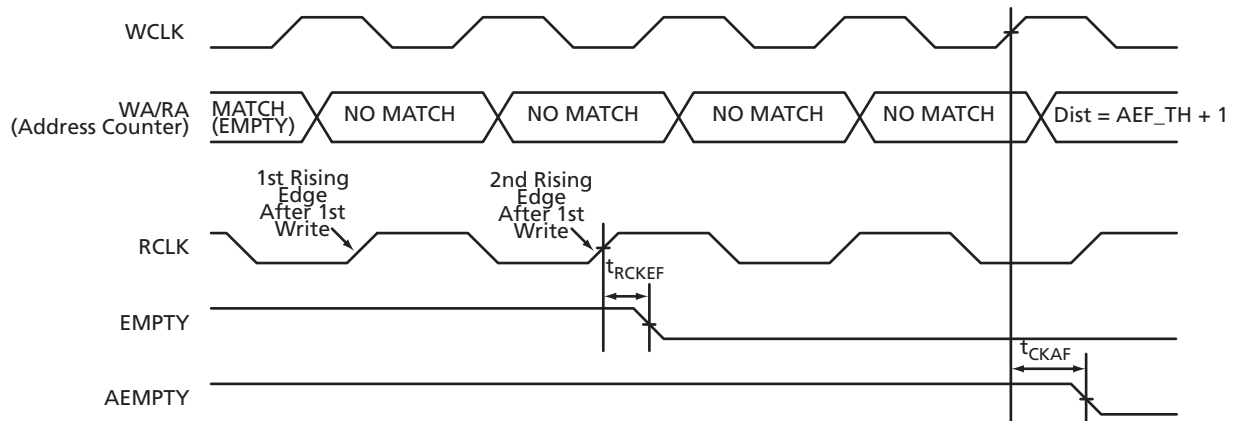
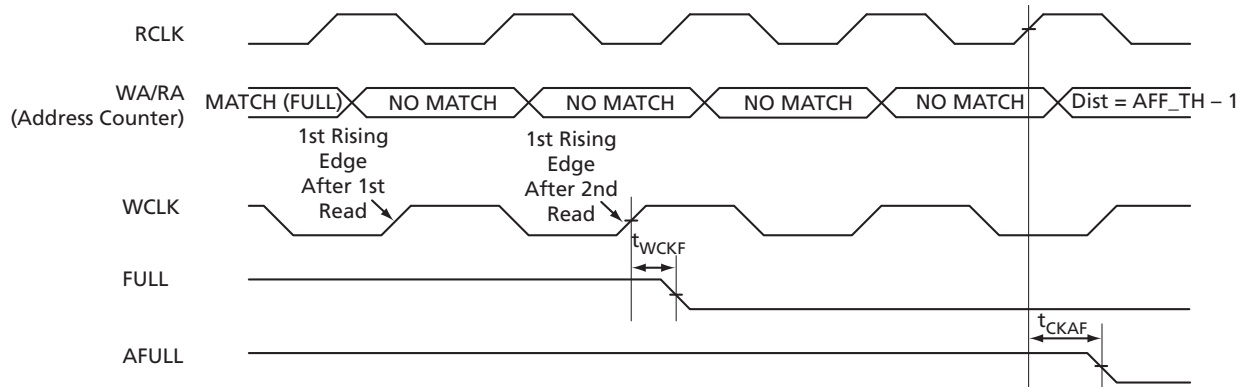

Figure 2-35 • FIFO EMPTY Flag and AEMPTY Flag Assertion

Figure 2-36 • FIFO FULL Flag and AFULL Flag Assertion

Figure 2-37 • FIFO EMPTY Flag and AEMPTY Flag Deassertion

Figure 2-38 • FIFO FULL Flag and AFULL Flag Deassertion

Timing Characteristics

1.5 V DC Core Voltage

Table 2-107 • FIFO
Worst Commercial-Case Conditions: $T_J = 70^\circ\text{C}$, $V_{CC} = 1.425\text{ V}$

Parameter	Description	Std.	Units
t_{ENS}	REN_B, WEN_B Setup Time	1.66	ns
t_{ENH}	REN_B, WEN_B Hold Time	0.13	ns
t_{BKS}	BLK_B Setup Time	0.30	ns
t_{BKH}	BLK_B Hold Time	0.00	ns
t_{DS}	Input Data (DI) Setup Time	0.63	ns
t_{DH}	Input Data (DI) Hold Time	0.20	ns
t_{CKQ1}	Clock HIGH to New Data Valid on DO (flow-through)	2.77	ns
t_{CKQ2}	Clock HIGH to New Data Valid on DO (pipelined)	1.50	ns
t_{RCKEF}	RCLK HIGH to Empty Flag Valid	2.94	ns
t_{WCKFF}	WCLK HIGH to Full Flag Valid	2.79	ns
t_{CKAF}	Clock HIGH to Almost Empty/Full Flag Valid	10.71	ns
t_{RSTFG}	RESET_B LOW to Empty/Full Flag Valid	2.90	ns
t_{RSTAF}	RESET_B LOW to Almost Empty/Full Flag Valid	10.60	ns
t_{RSTBQ}	RESET_B LOW to Data Out LOW on DO (flow-through)	1.68	ns
	RESET_B LOW to Data Out LOW on DO (pipelined)	1.68	ns
$t_{REMRSTB}$	RESET_B Removal	0.51	ns
$t_{RECRSTB}$	RESET_B Recovery	2.68	ns
$t_{MPWRSTB}$	RESET_B Minimum Pulse Width	0.68	ns
t_{CYC}	Clock Cycle Time	6.24	ns
F_{MAX}	Maximum Frequency for FIFO	160	MHz

Note: For specific junction temperature and voltage supply levels, refer to [Table 2-6 on page 2-6](#) for derating values.

1.2 V DC Core Voltage

Table 2-108 • FIFO

Worst Commercial-Case Conditions: $T_J = 70^\circ\text{C}$, $V_{CC} = 1.14\text{ V}$

Parameter	Description	Std.	Units
t_{ENS}	REN_B, WEN_B Setup Time	3.44	ns
t_{ENH}	REN_B, WEN_B Hold Time	0.26	ns
t_{BKS}	BLK_B Setup Time	0.30	ns
t_{BKH}	BLK_B Hold Time	0.00	ns
t_{DS}	Input Data (DI) Setup Time	1.30	ns
t_{DH}	Input Data (DI) Hold Time	0.41	ns
t_{CKQ1}	Clock HIGH to New Data Valid on DO (flow-through)	5.67	ns
t_{CKQ2}	Clock HIGH to New Data Valid on DO (pipelined)	3.02	ns
t_{RCKEF}	RCLK HIGH to Empty Flag Valid	6.02	ns
t_{WCKFF}	WCLK HIGH to Full Flag Valid	5.71	ns
t_{CKAF}	Clock HIGH to Almost Empty/Full Flag Valid	22.17	ns
t_{RSTFG}	RESET_B LOW to Empty/Full Flag Valid	5.93	ns
t_{RSTAF}	RESET_B LOW to Almost Empty/Full Flag Valid	21.94	ns
t_{RSTBQ}	RESET_B LOW to Data Out LOW on DO (flow-through)	3.41	ns
	RESET_B LOW to Data Out LOW on DO (pipelined)	4.09	3.41
$t_{REMRSTB}$	RESET_B Removal	1.02	ns
$t_{RECRSTB}$	RESET_B Recovery	5.48	ns
$t_{MPWRSTB}$	RESET_B Minimum Pulse Width	1.18	ns
t_{CYC}	Clock Cycle Time	10.90	ns
F_{MAX}	Maximum Frequency for FIFO	92	MHz

Note: For specific junction temperature and voltage supply levels, refer to [Table 2-7 on page 2-7](#) for derating values.

Embedded FlashROM Characteristics

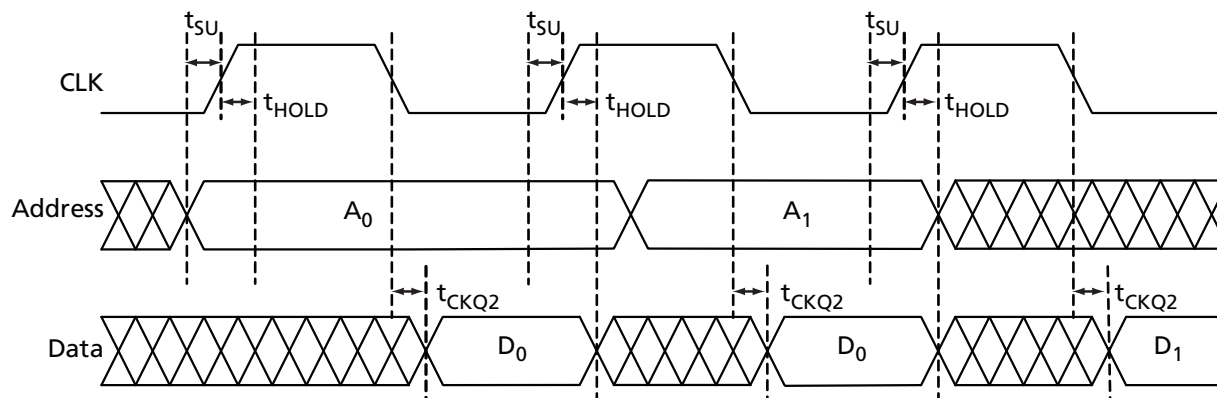

Figure 2-39 • Timing Diagram

Timing Characteristics

1.5 V DC Core Voltage

Table 2-109 • Embedded FlashROM Access Time

Worst Commercial-Case Conditions: $T_J = 70^\circ\text{C}$, $V_{CC} = 1.425\text{ V}$

Parameter	Description	Std.	Units
t_{SU}	Address Setup Time	0.57	ns
t_{HOLD}	Address Hold Time	0.00	ns
t_{CKQ2}	Clock to Out	20.90	ns
F_{MAX}	Maximum Clock Frequency	15	MHz

1.2 V DC Core Voltage

Table 2-110 • Embedded FlashROM Access Time

Worst Commercial-Case Conditions: $T_J = 70^\circ\text{C}$, $V_{CC} = 1.14\text{ V}$

Parameter	Description	Std.	Units
t_{SU}	Address Setup Time	0.59	ns
t_{HOLD}	Address Hold Time	0.00	ns
t_{CKQ2}	Clock to Out	35.74	ns
F_{MAX}	Maximum Clock Frequency	10	MHz

JTAG 1532 Characteristics

JTAG timing delays do not include JTAG I/Os. To obtain complete JTAG timing, add I/O buffer delays to the corresponding standard selected; refer to the I/O timing characteristics in the "User I/O Characteristics" section on page 2-15 for more details.

Timing Characteristics

1.5 V DC Core Voltage

Table 2-111 • JTAG 1532

Commercial-Case Conditions: $T_J = 70^\circ\text{C}$, Worst-Case VCC = 1.425 V

Parameter	Description	Std.	Units
t_{DISU}	Test Data Input Setup Time	1.00	ns
t_{DIHD}	Test Data Input Hold Time	2.00	ns
t_{TMSU}	Test Mode Select Setup Time	1.00	ns
t_{TMDHD}	Test Mode Select Hold Time	2.00	ns
t_{TCK2Q}	Clock to Q (data out)	8.00	ns
t_{RSTB2Q}	Reset to Q (data out)	25.00	ns
F_{TCKMAX}	TCK Maximum Frequency	15	MHz
t_{TRSTREM}	ResetB Removal Time	0.58	ns
t_{TRSTREC}	ResetB Recovery Time	0.00	ns
t_{TRSTMPW}	ResetB Minimum Pulse	TBD	ns

Note: For specific junction temperature and voltage supply levels, refer to Table 2-6 on page 2-6 for derating values.

1.2 V DC Core Voltage

Table 2-112 • JTAG 1532

Commercial-Case Conditions: $T_J = 70^\circ\text{C}$, Worst-Case VCC = 1.14 V

Parameter	Description	Std.	Units
t_{DISU}	Test Data Input Setup Time	1.50	ns
t_{DIHD}	Test Data Input Hold Time	3.00	ns
t_{TMSU}	Test Mode Select Setup Time	1.50	ns
t_{TMDHD}	Test Mode Select Hold Time	3.00	ns
t_{TCK2Q}	Clock to Q (data out)	11.00	ns
t_{RSTB2Q}	Reset to Q (data out)	30.00	ns
F_{TCKMAX}	TCK Maximum Frequency	9.00	MHz
t_{TRSTREM}	ResetB Removal Time	1.18	ns
t_{TRSTREC}	ResetB Recovery Time	0.00	ns
t_{TRSTMPW}	ResetB Minimum Pulse	TBD	ns

Note: For specific junction temperature and voltage supply levels, refer to Table 2-6 on page 2-6 for derating values.

Actel Safety Critical, Life Support, and High-Reliability Applications Policy

The Actel products described in this advance status datasheet may not have completed Actel's qualification process. Actel may amend or enhance products during the product introduction and qualification process, resulting in changes in device functionality or performance. It is the responsibility of each customer to ensure the fitness of any Actel product (but especially a new product) for a particular purpose, including appropriateness for safety-critical, life-support, and other high-reliability applications. Consult Actel's Terms and Conditions for specific liability exclusions relating to life-support applications. A reliability report covering all of Actel's products is available on the Actel website at http://www.actel.com/documents/ORT_Report.pdf. Actel also offers a variety of enhanced qualification and lot acceptance screening procedures. Contact your local Actel sales office for additional reliability information.

3 – Package Pin Assignments

36-Pin UC

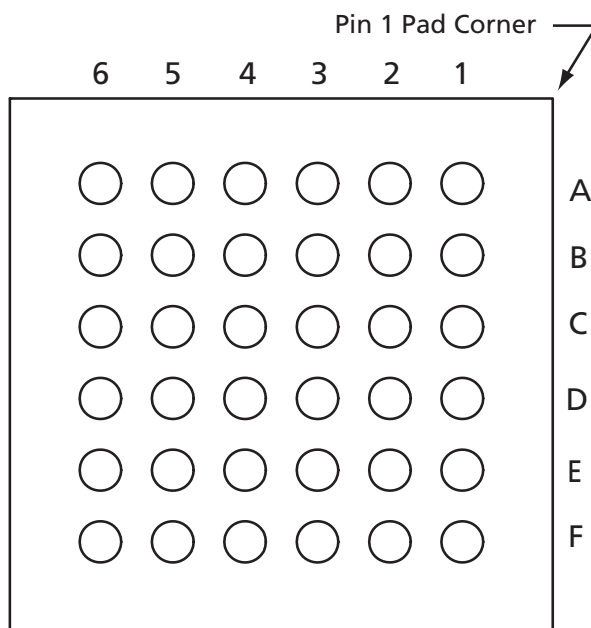

Note: This is the bottom view of the package.

Note

For Package Manufacturing and Environmental information, visit the Resource Center at <http://www.actel.com/products/solutions/package/docs.aspx>.

36-Pin UC	
Pin Number	AGLN010 Function
A1	IO21RSB1
A2	IO18RSB1
A3	IO13RSB1
A4	GDC0/IO00RSB0
A5	IO06RSB0
A6	GDA0/IO04RSB0
B1	GEC0/IO37RSB1
B2	IO20RSB1
B3	IO15RSB1
B4	IO09RSB0
B5	IO08RSB0
B6	IO07RSB0
C1	IO22RSB1
C2	GEA0/IO34RSB1
C3	GND
C4	GND
C5	VCCIB0
C6	IO02RSB0
D1	IO33RSB1
D2	VCCIB1
D3	VCC
D4	VCC
D5	IO10RSB0
D6	IO11RSB0
E1	IO32RSB1
E2	FF/IO31RSB1
E3	TCK
E4	VPUMP
E5	TRST
E6	VJTAG
F1	IO29RSB1
F2	IO25RSB1
F3	IO23RSB1
F4	TDI

36-Pin UC	
Pin Number	AGLN010 Function
F5	TMS
F6	TDO

81-Pin UC

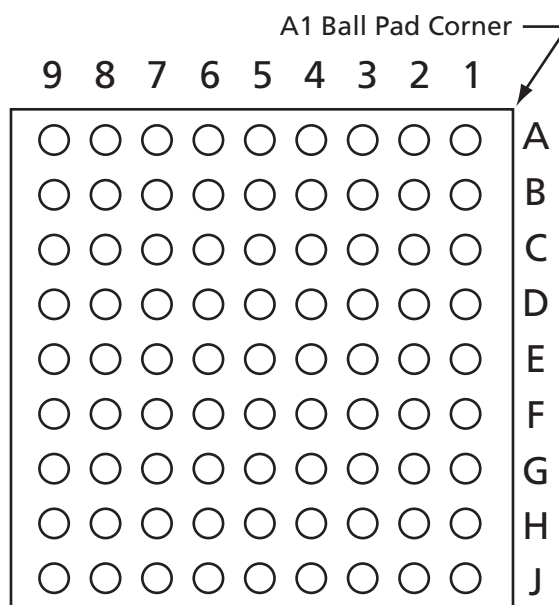

Note: This is the bottom view of the package.

Note

For Package Manufacturing and Environmental information, visit the Resource Center at <http://www.actel.com/products/solutions/package/docs.aspx>.

81-Pin UC		81-Pin UC		81-Pin UC	
Pin Number	AGLN020 Function	Pin Number	AGLN020 Function	Pin Number	AGLN020 Function
A1	IO64RSB2	E1	GEC0/IO48RSB2	J1	IO38RSB1
A2	IO54RSB2	E2	GEA0/IO47RSB2	J2	IO37RSB1
A3	IO57RSB2	E3	NC	J3	IO33RSB1
A4	IO36RSB1	E4	VCCIB1	J4	IO30RSB1
A5	IO32RSB1	E5	VCC	J5	IO27RSB1
A6	IO24RSB1	E6	VCCIB0	J6	IO23RSB1
A7	IO20RSB1	E7	NC	J7	TCK
A8	IO04RSB0	E8	GDA0/IO15RSB0	J8	TMS
A9	IO08RSB0	E9	GDC0/IO14RSB0	J9	VPUMP
B1	IO59RSB2	F1	IO46RSB2		
B2	IO55RSB2	F2	IO45RSB2		
B3	IO62RSB2	F3	NC		
B4	IO34RSB1	F4	GND		
B5	IO28RSB1	F5	VCCIB1		
B6	IO22RSB1	F6	NC		
B7	IO18RSB1	F7	NC		
B8	IO00RSB0	F8	IO16RSB0		
B9	IO03RSB0	F9	IO17RSB0		
C1	IO51RSB2	G1	IO43RSB2		
C2	IO50RSB2	G2	IO42RSB2		
C3	NC	G3	IO41RSB2		
C4	NC	G4	IO31RSB1		
C5	NC	G5	NC		
C6	NC	G6	IO21RSB1		
C7	NC	G7	NC		
C8	IO10RSB0	G8	VJTAG		
C9	IO07RSB0	G9	TRST		
D1	IO49RSB2	H1	IO40RSB2		
D2	IO44RSB2	H2	FF/IO39RSB1		
D3	NC	H3	IO35RSB1		
D4	VCC	H4	IO29RSB1		
D5	VCCIB2	H5	IO26RSB1		
D6	GND	H6	IO25RSB1		
D7	NC	H7	IO19RSB1		
D8	IO13RSB0	H8	TDI		
D9	IO12RSB0	H9	TDO		

81-Pin UC		81-Pin UC		81-Pin UC	
Pin Number	AGLN030Z Function	Pin Number	AGLN030Z Function	Pin Number	AGLN030Z Function
A1	IO00RSB0	D9	IO30RSB0	H8	TDI
A2	IO02RSB0	E1	GEB0/IO71RSB1	H9	TDO
A3	IO06RSB0	E2	GEA0/IO72RSB1	J1	IO63RSB1
A4	IO11RSB0	E3	GEC0/IO73RSB1	J2	IO61RSB1
A5	IO16RSB0	E4	VCCIB1	J3	IO59RSB1
A6	IO19RSB0	E5	VCC	J4	IO56RSB1
A7	IO22RSB0	E6	VCCIB0	J5	IO52RSB1
A8	IO24RSB0	E7	GDC0/IO32RSB0	J6	IO44RSB1
A9	IO26RSB0	E8	GDA0/IO33RSB0	J7	TCK
B1	IO81RSB1	E9	GDB0/IO34RSB0	J8	TMS
B2	IO04RSB0	F1	IO68RSB1	J9	VPUMP
B3	IO10RSB0	F2	IO67RSB1		
B4	IO13RSB0	F3	IO64RSB1		
B5	IO15RSB0	F4	GND		
B6	IO20RSB0	F5	VCCIB1		
B7	IO21RSB0	F6	IO47RSB1		
B8	IO28RSB0	F7	IO36RSB0		
B9	IO25RSB0	F8	IO38RSB0		
C1	IO79RSB1	F9	IO40RSB0		
C2	IO80RSB1	G1	IO65RSB1		
C3	IO08RSB0	G2	IO66RSB1		
C4	IO12RSB0	G3	IO57RSB1		
C5	IO17RSB0	G4	IO53RSB1		
C6	IO14RSB0	G5	IO49RSB1		
C7	IO18RSB0	G6	IO45RSB1		
C8	IO29RSB0	G7	IO46RSB1		
C9	IO27RSB0	G8	VJTAG		
D1	IO74RSB1	G9	TRST		
D2	IO76RSB1	H1	IO62RSB1		
D3	IO77RSB1	H2	FF/IO60RSB1		
D4	VCC	H3	IO58RSB1		
D5	VCCIB0	H4	IO54RSB1		
D6	GND	H5	IO48RSB1		
D7	IO23RSB0	H6	IO43RSB1		
D8	IO31RSB0	H7	IO42RSB1		

81-Pin CS

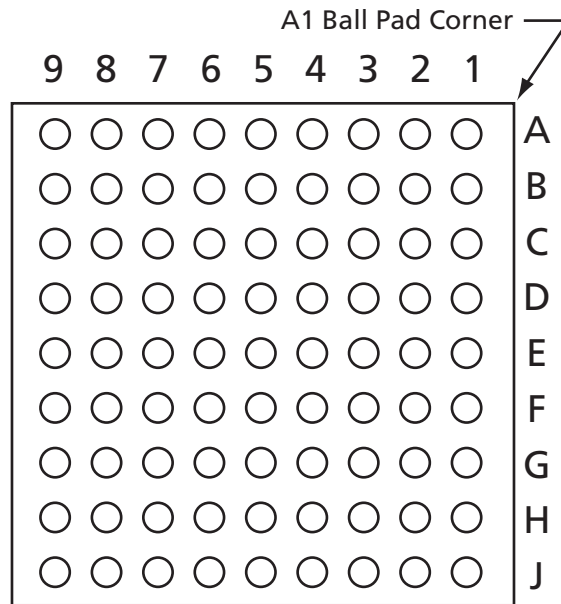

Note: This is the bottom view of the package.

Note

For Package Manufacturing and Environmental information, visit the Resource Center at <http://www.actel.com/products/solutions/package/docs.aspx>.

81-Pin CS		81-Pin CS		81-Pin CS	
Pin Number	AGLN020 Function	Pin Number	AGLN020 Function	Pin Number	AGLN020 Function
A1	IO64RSB2	E1	GEC0/IO48RSB2	J1	IO38RSB1
A2	IO54RSB2	E2	GEA0/IO47RSB2	J2	IO37RSB1
A3	IO57RSB2	E3	NC	J3	IO33RSB1
A4	IO36RSB1	E4	VCCIB1	J4	IO30RSB1
A5	IO32RSB1	E5	VCC	J5	IO27RSB1
A6	IO24RSB1	E6	VCCIB0	J6	IO23RSB1
A7	IO20RSB1	E7	NC	J7	TCK
A8	IO04RSB0	E8	GDA0/IO15RSB0	J8	TMS
A9	IO08RSB0	E9	GDC0/IO14RSB0	J9	VPUMP
B1	IO59RSB2	F1	IO46RSB2		
B2	IO55RSB2	F2	IO45RSB2		
B3	IO62RSB2	F3	NC		
B4	IO34RSB1	F4	GND		
B5	IO28RSB1	F5	VCCIB1		
B6	IO22RSB1	F6	NC		
B7	IO18RSB1	F7	NC		
B8	IO00RSB0	F8	IO16RSB0		
B9	IO03RSB0	F9	IO17RSB0		
C1	IO51RSB2	G1	IO43RSB2		
C2	IO50RSB2	G2	IO42RSB2		
C3	NC	G3	IO41RSB2		
C4	NC	G4	IO31RSB1		
C5	NC	G5	NC		
C6	NC	G6	IO21RSB1		
C7	NC	G7	NC		
C8	IO10RSB0	G8	VJTAG		
C9	IO07RSB0	G9	TRST		
D1	IO49RSB2	H1	IO40RSB2		
D2	IO44RSB2	H2	FF/IO39RSB1		
D3	NC	H3	IO35RSB1		
D4	VCC	H4	IO29RSB1		
D5	VCCIB2	H5	IO26RSB1		
D6	GND	H6	IO25RSB1		
D7	NC	H7	IO19RSB1		
D8	IO13RSB0	H8	TDI		
D9	IO12RSB0	H9	TDO		

81-Pin CS	
Pin Number	AGLN030Z Function
A1	IO00RSB0
A2	IO02RSB0
A3	IO06RSB0
A4	IO11RSB0
A5	IO16RSB0
A6	IO19RSB0
A7	IO22RSB0
A8	IO24RSB0
A9	IO26RSB0
B1	IO81RSB1
B2	IO04RSB0
B3	IO10RSB0
B4	IO13RSB0
B5	IO15RSB0
B6	IO20RSB0
B7	IO21RSB0
B8	IO28RSB0
B9	IO25RSB0
C1	IO79RSB1
C2	IO80RSB1
C3	IO08RSB0
C4	IO12RSB0
C5	IO17RSB0
C6	IO14RSB0
C7	IO18RSB0
C8	IO29RSB0
C9	IO27RSB0
D1	IO74RSB1
D2	IO76RSB1
D3	IO77RSB1
D4	VCC
D5	VCCIB0
D6	GND
D7	IO23RSB0
D8	IO31RSB0

81-Pin CS	
Pin Number	AGLN030Z Function
D9	IO30RSB0
E1	GEB0/IO71RSB1
E2	GEA0/IO72RSB1
E3	GEC0/IO73RSB1
E4	VCCIB1
E5	VCC
E6	VCCIB0
E7	GDC0/IO32RSB0
E8	GDA0/IO33RSB0
E9	GDB0/IO34RSB0
F1	IO68RSB1
F2	IO67RSB1
F3	IO64RSB1
F4	GND
F5	VCCIB1
F6	IO47RSB1
F7	IO36RSB0
F8	IO38RSB0
F9	IO40RSB0
G1	IO65RSB1
G2	IO66RSB1
G3	IO57RSB1
G4	IO53RSB1
G5	IO49RSB1
G6	IO44RSB1
G7	IO46RSB1
G8	VJTAG
G9	TRST
H1	IO62RSB1
H2	FF/IO60RSB1
H3	IO58RSB1
H4	IO54RSB1
H5	IO48RSB1
H6	IO43RSB1
H7	IO42RSB1

81-Pin CS	
Pin Number	AGLN030Z Function
H8	TDI
H9	TDO
J1	IO63RSB1
J2	IO61RSB1
J3	IO59RSB1
J4	IO56RSB1
J5	IO52RSB1
J6	IO45RSB1
J7	TCK
J8	TMS
J9	VPUMP

81-Pin CS		81-Pin CS		81-Pin CS	
Pin Number	AGLN060 Function	Pin Number	AGLN060 Function	Pin Number	AGLN060 Function
A1	GAA0/IO02RSB0	D8	GCC1/IO35RSB0	H6	IO56RSB1
A2	GAA1/IO03RSB0	D9	GCC0/IO36RSB0	H7 ²	GDA2/IO51RSB1
A3	GAC0/IO06RSB0	E1	GFB0/IO83RSB1	H8	TDI
A4	IO09RSB0	E2	GFB1/IO84RSB1	H9	TDO
A5	IO13RSB0	E3	GFA1/IO81RSB1	J1	GEA2/IO68RSB1
A6	IO18RSB0	E4	VCCIB1	J2	GEC2/IO66RSB1
A7	GBB0/IO21RSB0	E5	VCC	J3	IO64RSB1
A8	GBA1/IO24RSB0	E6	VCCIB0	J4	IO61RSB1
A9	GBA2/IO25RSB0	E7	GCA1/IO39RSB0	J5	IO58RSB1
B1	GAA2/IO95RSB1	E8	GCA0/IO40RSB0	J6	IO55RSB1
B2	GAB0/IO04RSB0	E9	GCB2/IO42RSB0	J7	TCK
B3	GAC1/IO07RSB0	F1 ¹	VCCPLF	J8	TMS
B4	IO08RSB0	F2 ¹	VCOMPLF	J9	VPUMP
B5	IO15RSB0	F3	GND		
B6	GBC0/IO19RSB0	F4	GND		
B7	GBB1/IO22RSB0	F5	VCCIB1		
B8	IO26RSB0	F6	GND		
B9	GBB2/IO27RSB0	F7	GDA1/IO49RSB0		
C1	GAB2/IO93RSB1	F8	GDC1/IO45RSB0		
C2	IO94RSB1	F9	GDC0/IO46RSB0		
C3	GND	G1	GEA0/IO69RSB1		
C4	IO10RSB0	G2	GEC1/IO74RSB1		
C5	IO17RSB0	G3	GEB1/IO72RSB1		
C6	GND	G4	IO63RSB1		
C7	GBA0/IO23RSB0	G5	IO60RSB1		
C8	GBC2/IO29RSB0	G6	IO54RSB1		
C9	IO31RSB0	G7	GDB2/IO52RSB1		
D1	GAC2/IO91RSB1	G8	VJTAG		
D2	IO92RSB1	G9	TRST		
D3	GFA2/IO80RSB1	H1	GEA1/IO70RSB1		
D4	VCC	H2	FF/GEB2/IO67RSB1		
D5	VCCIB0	H3	IO65RSB1		
D6	GND	H4	IO62RSB1		
D7	GCC2/IO43RSB0	H5	IO59RSB1		

Notes:

1. Pin numbers F1 and F2 must be connected to ground because a PLL is not supported for AGLN060-CS81.
2. The bus hold attribute (hold previous I/O state in Flash*Freeze mode) is not supported for pin H7 in AGLN060-CS81.

81-Pin CS		81-Pin CS		81-Pin CS	
Pin Number	AGLN060Z Function	Pin Number	AGLN060Z Function	Pin Number	AGLN060Z Function
A1	GAA0/IO02RSB0	D8	GCC1/IO35RSB0	H6	IO56RSB1
A2	GAA1/IO03RSB0	D9	GCC0/IO36RSB0	H7 ²	GDA2/IO51RSB1
A3	GAC0/IO06RSB0	E1	GFB0/IO83RSB1	H8	TDI
A4	IO09RSB0	E2	GFB1/IO84RSB1	H9	TDO
A5	IO13RSB0	E3	GFA1/IO81RSB1	J1	GEA2/IO68RSB1
A6	IO18RSB0	E4	VCCIB1	J2	GEC2/IO66RSB1
A7	GBB0/IO21RSB0	E5	VCC	J3	IO64RSB1
A8	GBA1/IO24RSB0	E6	VCCIB0	J4	IO61RSB1
A9	GBA2/IO25RSB0	E7	GCA1/IO39RSB0	J5	IO58RSB1
B1	GAA2/IO95RSB1	E8	GCA0/IO40RSB0	J6	IO55RSB1
B2	GAB0/IO04RSB0	E9	GCB2/IO42RSB0	J7	TCK
B3	GAC1/IO07RSB0	F1 ¹	VCCPLF	J8	TMS
B4	IO08RSB0	F2 ¹	VCOMPLF	J9	VPUMP
B5	IO15RSB0	F3	GND		
B6	GBC0/IO19RSB0	F4	GND		
B7	GBB1/IO22RSB0	F5	VCCIB1		
B8	IO26RSB0	F6	GND		
B9	GBB2/IO27RSB0	F7	GDA1/IO49RSB0		
C1	GAB2/IO93RSB1	F8	GDC1/IO45RSB0		
C2	IO94RSB1	F9	GDC0/IO46RSB0		
C3	GND	G1	GEA0/IO69RSB1		
C4	IO10RSB0	G2	GEC1/IO74RSB1		
C5	IO17RSB0	G3	GEB1/IO72RSB1		
C6	GND	G4	IO63RSB1		
C7	GBA0/IO23RSB0	G5	IO60RSB1		
C8	GBC2/IO29RSB0	G6	IO54RSB1		
C9	IO31RSB0	G7	GDB2/IO52RSB1		
D1	GAC2/IO91RSB1	G8	VJTAG		
D2	IO92RSB1	G9	TRST		
D3	GFA2/IO80RSB1	H1	GEA1/IO70RSB1		
D4	VCC	H2	FF/GEB2/IO67RSB1		
D5	VCCIB0	H3	IO65RSB1		
D6	GND	H4	IO62RSB1		
D7	GCC2/IO43RSB0	H5	IO59RSB1		

Notes:

1. Pin numbers F1 and F2 must be connected to ground because a PLL is not supported for AGLN060Z-CS81.
2. The bus hold attribute (hold previous I/O state in Flash*Freeze mode) is not supported for pin H7 in AGLN060Z-CS81.

81-Pin CS		81-Pin CS		81-Pin CS	
Pin Number	AGLN125 Function	Pin Number	AGLN125 Function	Pin Number	AGLN125 Function
A1	GAA0/IO00RSB0	E1	GFB0/IO120RSB1	J1	GEA2/IO103RSB1
A2	GAA1/IO01RSB0	E2	GFB1/IO121RSB1	J2	GEC2/IO101RSB1
A3	GAC0/IO04RSB0	E3	GFA1/IO118RSB1	J3	IO97RSB1
A4	IO13RSB0	E4	VCCIB1	J4	IO93RSB1
A5	IO22RSB0	E5	VCC	J5	IO90RSB1
A6	IO32RSB0	E6	VCCIB0	J6	IO78RSB1
A7	GBB0/IO37RSB0	E7	GCA0/IO56RSB0	J7	TCK
A8	GBA1/IO40RSB0	E8	GCA1/IO55RSB0	J8	TMS
A9	GBA2/IO41RSB0	E9	GCB2/IO58RSB0	J9	VPUMP
B1	GAA2/IO132RSB1	F1*	VCCPLF		
B2	GAB0/IO02RSB0	F2*	VCOMPLF		
B3	GAC1/IO05RSB0	F3	GND		
B4	IO11RSB0	F4	GND		
B5	IO25RSB0	F5	VCCIB1		
B6	GBC0/IO35RSB0	F6	GND		
B7	GBB1/IO38RSB0	F7	GDA1/IO65RSB0		
B8	IO42RSB0	F8	GDC1/IO61RSB0		
B9	GBB2/IO43RSB0	F9	GDC0/IO62RSB0		
C1	GAB2/IO130RSB1	G1	GEA0/IO104RSB1		
C2	IO131RSB1	G2	GEC0/IO108RSB1		
C3	GND	G3	GEB1/IO107RSB1		
C4	IO15RSB0	G4	IO96RSB1		
C5	IO28RSB0	G5	IO92RSB1		
C6	GND	G6	IO72RSB1		
C7	GBA0/IO39RSB0	G7	GDB2/IO68RSB1		
C8	GBC2/IO45RSB0	G8	VJTAG		
C9	IO47RSB0	G9	TRST		
D1	GAC2/IO128RSB1	H1	GEA1/IO105RSB1		
D2	IO129RSB1	H2	FF/GEB2/IO102RSB1		
D3	GFA2/IO117RSB1	H3	IO99RSB1		
D4	VCC	H4	IO94RSB1		
D5	VCCIB0	H5	IO91RSB1		
D6	GND	H6	IO81RSB1		
D7	GCC2/IO59RSB0	H7	GDA2/IO67RSB1		
D8	GCC1/IO51RSB0	H8	TDI		
D9	GCC0/IO52RSB0	H9	TDO		

Note: * Pin numbers F1 and F2 must be connected to ground because a PLL is not supported for AGLN125-CS81.

81-Pin CS		81-Pin CS		81-Pin CS	
Pin Number	AGLN125Z Function	Pin Number	AGLN125Z Function	Pin Number	AGLN125Z Function
A1	GAA0/IO00RSB0	E1	GFB0/IO120RSB1	J1	GEA2/IO103RSB1
A2	GAA1/IO01RSB0	E2	GFB1/IO121RSB1	J2	GEC2/IO101RSB1
A3	GAC0/IO04RSB0	E3	GFA1/IO118RSB1	J3	IO97RSB1
A4	IO13RSB0	E4	VCCIB1	J4	IO93RSB1
A5	IO22RSB0	E5	VCC	J5	IO90RSB1
A6	IO32RSB0	E6	VCCIB0	J6	IO78RSB1
A7	GBB0/IO37RSB0	E7	GCA0/IO56RSB0	J7	TCK
A8	GBA1/IO40RSB0	E8	GCA1/IO55RSB0	J8	TMS
A9	GBA2/IO41RSB0	E9	GCB2/IO58RSB0	J9	VPUMP
B1	GAA2/IO132RSB1	F1*	VCCPLF		
B2	GAB0/IO02RSB0	F2*	VCOMPLF		
B3	GAC1/IO05RSB0	F3	GND		
B4	IO11RSB0	F4	GND		
B5	IO25RSB0	F5	VCCIB1		
B6	GBC0/IO35RSB0	F6	GND		
B7	GBB1/IO38RSB0	F7	GDA1/IO65RSB0		
B8	IO42RSB0	F8	GDC1/IO61RSB0		
B9	GBB2/IO43RSB0	F9	GDC0/IO62RSB0		
C1	GAB2/IO130RSB1	G1	GEA0/IO104RSB1		
C2	IO131RSB1	G2	GEC0/IO108RSB1		
C3	GND	G3	GEB1/IO107RSB1		
C4	IO15RSB0	G4	IO96RSB1		
C5	IO28RSB0	G5	IO92RSB1		
C6	GND	G6	IO72RSB1		
C7	GBA0/IO39RSB0	G7	GDB2/IO68RSB1		
C8	GBC2/IO45RSB0	G8	VJTAG		
C9	IO47RSB0	G9	TRST		
D1	GAC2/IO128RSB1	H1	GEA1/IO105RSB1		
D2	IO129RSB1	H2	FF/GEB2/IO102RSB1		
D3	GFA2/IO117RSB1	H3	IO99RSB1		
D4	VCC	H4	IO94RSB1		
D5	VCCIB0	H5	IO91RSB1		
D6	GND	H6	IO81RSB1		
D7	GCC2/IO59RSB0	H7	GDA2/IO67RSB1		
D8	GCC1/IO51RSB0	H8	TDI		
D9	GCC0/IO52RSB0	H9	TDO		

Note: * Pin numbers F1 and F2 must be connected to ground because a PLL is not supported for AGLN125Z-CS81.

81-Pin CS		81-Pin CS		81-Pin CS	
Pin Number	AGLN250 Function	Pin Number	AGLN250 Function	Pin Number	AGLN250 Function
A1	GAA0/IO00RSB0	E1	GFB0/IO109NDB3	J1	GEA2/IO97RSB2
A2	GAA1/IO01RSB0	E2	GFB1/IO109PDB3	J2	GEC2/IO95RSB2
A3	GAC0/IO04RSB0	E3	GFA1/IO108PSB3	J3	IO92RSB2
A4	IO13RSB0	E4	VCCIB3	J4	IO88RSB2
A5	IO21RSB0	E5	VCC	J5	IO84RSB2
A6	IO27RSB0	E6	VCCIB1	J6	IO74RSB2
A7	GBB0/IO37RSB0	E7	GCA0/IO50NDB1	J7	TCK
A8	GBA1/IO40RSB0	E8	GCA1/IO50PDB1	J8	TMS
A9	GBA2/IO41PPB1	E9	GCB2/IO52PPB1	J9	VPUMP
B1	GAA2/IO118UPB3	F1*	VCCPLF		
B2	GAB0/IO02RSB0	F2*	VCOMPLF		
B3	GAC1/IO05RSB0	F3	GND		
B4	IO11RSB0	F4	GND		
B5	IO23RSB0	F5	VCCIB2		
B6	GBC0/IO35RSB0	F6	GND		
B7	GBB1/IO38RSB0	F7	GDA1/IO60USB1		
B8	IO41NPB1	F8	GDC1/IO58UDB1		
B9	GBB2/IO42PSB1	F9	GDC0/IO58VDB1		
C1	GAB2/IO117UPB3	G1	GEA0/IO98NDB3		
C2	IO118VPB3	G2	GEC1/IO100PDB3		
C3	GND	G3	GEC0/IO100NDB3		
C4	IO15RSB0	G4	IO91RSB2		
C5	IO25RSB0	G5	IO86RSB2		
C6	GND	G6	IO71RSB2		
C7	GBA0/IO39RSB0	G7	GDB2/IO62RSB2		
C8	GBC2/IO43B1	G8	VJTAG		
C9	IO43NDB1	G9	TRST		
D1	GAC2/IO116USB3	H1	GEA1/IO98PDB3		
D2	IO117VPB3	H2	FF/GEB2/IO96RSB2		
D3	GFA2/IO107PSB3	H3	IO93RSB2		
D4	VCC	H4	IO90RSB2		
D5	VCCIB0	H5	IO85RSB2		
D6	GND	H6	IO77RSB2		
D7	IO52NPB1	H7	GDA2/IO61RSB2		
D8	GCC1/IO48PDB1	H8	TDI		
D9	GCC0/IO48NDB1	H9	TDO		

Note: * Pin numbers F1 and F2 must be connected to ground because a PLL is not supported for AGLN250-CS81.

81-Pin CS		81-Pin CS		81-Pin CS	
Pin Number	AGLN250Z Function	Pin Number	AGLN250Z Function	Pin Number	AGLN250Z Function
A1	GAA0/IO00RSB0	E1	GFB0/IO59RSB3	J1	GEA2/IO50RSB2
A2	GAA1/IO01RSB0	E2	GFB1/IO60RSB3	J2	GEC2/IO48RSB2
A3	GAC0/IO04RSB0	E3	GFA1/IO58RSB3	J3	IO46RSB2
A4	IO07RSB0	E4	VCCIB3	J4	IO43RSB2
A5	IO09RSB0	E5	VCC	J5	IO40RSB2
A6	IO12RSB0	E6	VCCIB1	J6	IO38RSB2
A7	GBB0/IO16RSB0	E7	GCA0/IO28RSB1	J7	TCK
A8	GBA1/IO19RSB0	E8	GCA1/IO27RSB1	J8	TMS
A9	GBA2/IO20RSB1	E9	GCB2/IO29RSB1	J9	VPUMP
B1	GAA2/IO67RSB3	F1*	VCCPLF		
B2	GAB0/IO02RSB0	F2*	VCOMPLF		
B3	GAC1/IO05RSB0	F3	GND		
B4	IO06RSB0	F4	GND		
B5	IO10RSB0	F5	VCCIB2		
B6	GBC0/IO14RSB0	F6	GND		
B7	GBB1/IO17RSB0	F7	GDA1/IO33RSB1		
B8	IO21RSB1	F8	GDC1/IO31RSB1		
B9	GBB2/IO22RSB1	F9	GDC0/IO32RSB1		
C1	GAB2/IO65RSB3	G1	GEA0/IO51RSB3		
C2	IO66RSB3	G2	GEC1/IO54RSB3		
C3	GND	G3	GEC0/IO53RSB3		
C4	IO08RSB0	G4	IO45RSB2		
C5	IO11RSB0	G5	IO42RSB2		
C6	GND	G6	IO37RSB2		
C7	GBA0/IO18RSB0	G7	GDB2/IO35RSB2		
C8	GBC2/IO23RSB1	G8	VJTAG		
C9	IO24RSB1	G9	TRST		
D1	GAC2/IO63RSB3	H1	GEA1/IO52RSB3		
D2	IO64RSB3	H2	FF/GEB2/IO49RSB2		
D3	GFA2/IO56RSB3	H3	IO47RSB2		
D4	VCC	H4	IO44RSB2		
D5	VCCIB0	H5	IO41RSB2		
D6	GND	H6	IO39RSB2		
D7	IO30RSB1	H7	GDA2/IO34RSB2		
D8	GCC1/IO25RSB1	H8	TDI		
D9	GCC0/IO26RSB1	H9	TDO		

Note: * Pin numbers F1 and F2 must be connected to ground because a PLL is not supported for AGLN250Z-CS81.

48-Pin QFN

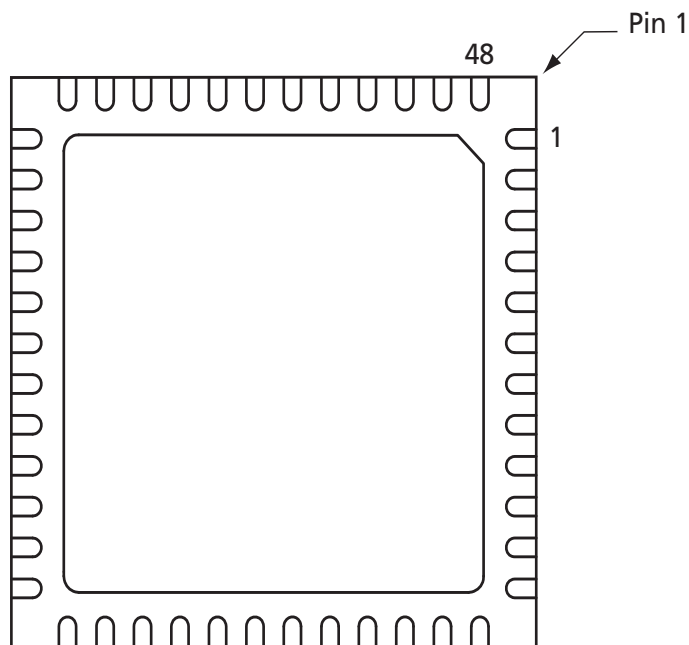

Notes:

1. This is the bottom view of the package.
2. The die attach paddle of the package is tied to ground (GND).

Note

For Package Manufacturing and Environmental information, visit the Resource Center at <http://www.actel.com/products/solutions/package/docs.aspx>.

48-Pin QFN	
Pin Number	AGLN010 Function
1	GEC0/IO37RSB1
2	IO36RSB1
3	GEA0/IO34RSB1
4	IO22RSB1
5	GND
6	VCCIB1
7	IO24RSB1
8	IO33RSB1
9	IO26RSB1
10	IO32RSB1
11	IO27RSB1
12	IO29RSB1
13	IO30RSB1
14	FF/IO31RSB1
15	IO28RSB1
16	IO25RSB1
17	IO23RSB1
18	VCC
19	VCCIB1
20	IO17RSB1
21	IO14RSB1
22	TCK
23	TDI
24	TMS
25	VPUMP
26	TDO
27	TRST
28	VJTAG
29	IO11RSB0
30	IO10RSB0
31	IO09RSB0
32	IO08RSB0
33	VCCIB0
34	GND
35	VCC

48-Pin QFN	
Pin Number	AGLN010 Function
36	IO07RSB0
37	IO06RSB0
38	GDA0/IO05RSB0
39	IO03RSB0
40	GDC0/IO01RSB0
41	IO12RSB1
42	IO13RSB1
43	IO15RSB1
44	IO16RSB1
45	IO18RSB1
46	IO19RSB1
47	IO20RSB1
48	IO21RSB1

48-Pin QFN	
Pin Number	AGLN030Z Function
1	IO82RSB1
2	GEC0/IO73RSB1
3	GEA0/IO72RSB1
4	GEB0/IO71RSB1
5	GND
6	VCCIB1
7	IO68RSB1
8	IO67RSB1
9	IO66RSB1
10	IO65RSB1
11	IO64RSB1
12	IO62RSB1
13	IO61RSB1
14	FF/IO60RSB1
15	IO57RSB1
16	IO55RSB1
17	IO53RSB1
18	VCC
19	VCCIB1
20	IO46RSB1
21	IO42RSB1
22	TCK
23	TDI
24	TMS
25	VPUMP
26	TDO
27	TRST
28	VJTAG
29	IO38RSB0
30	GDB0/IO34RSB0
31	GDA0/IO33RSB0
32	GDC0/IO32RSB0
33	VCCIB0
34	GND
35	VCC
36	IO25RSB0

48-Pin QFN	
Pin Number	AGLN030Z Function
37	IO24RSB0
38	IO22RSB0
39	IO20RSB0
40	IO18RSB0
41	IO16RSB0
42	IO14RSB0
43	IO10RSB0
44	IO08RSB0
45	IO06RSB0
46	IO04RSB0
47	IO02RSB0
48	IO00RSB0

68-Pin QFN

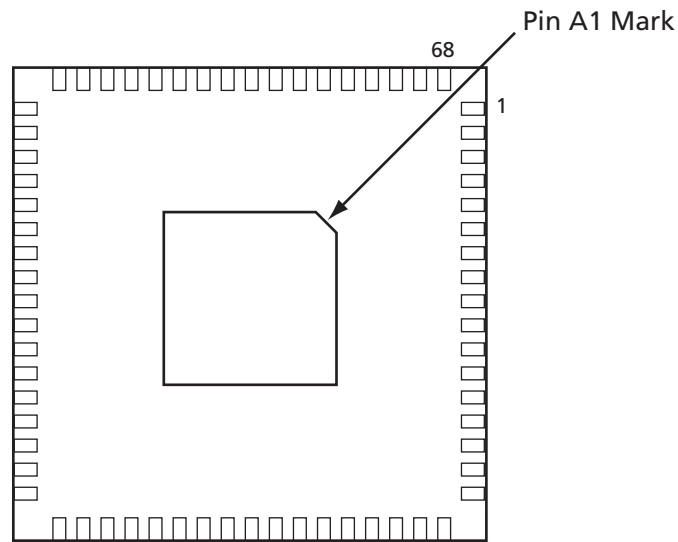
**Notes:**

1. This is the bottom view of the package.
2. The die attach paddle of the package is tied to ground (GND).

Note

For Package Manufacturing and Environmental information, visit the Resource Center at <http://www.actel.com/products/solutions/package/docs.aspx>.

68-Pin QFN		68-Pin QFN	
Pin Number	AGLN015 Function	Pin Number	AGLN015 Function
1	IO60RSB2	36	TDO
2	IO54RSB2	37	TRST
3	IO52RSB2	38	VJTAG
4	IO50RSB2	39	IO17RSB0
5	IO49RSB2	40	IO16RSB0
6	GEC0/IO48RSB2	41	GDA0/IO15RSB0
7	GEA0/IO47RSB2	42	GDC0/IO14RSB0
8	VCC	43	IO13RSB0
9	GND	44	VCCIB0
10	VCCIB2	45	GND
11	IO46RSB2	46	VCC
12	IO45RSB2	47	IO12RSB0
13	IO44RSB2	48	IO11RSB0
14	IO43RSB2	49	IO09RSB0
15	IO42RSB2	50	IO05RSB0
16	IO41RSB2	51	IO00RSB0
17	IO40RSB2	52	IO07RSB0
18	FF/IO39RSB1	53	IO03RSB0
19	IO37RSB1	54	IO18RSB1
20	IO35RSB1	55	IO20RSB1
21	IO33RSB1	56	IO22RSB1
22	IO31RSB1	57	IO24RSB1
23	IO30RSB1	58	IO28RSB1
24	VCC	59	NC
25	GND	60	GND
26	VCCIB1	61	NC
27	IO27RSB1	62	IO32RSB1
28	IO25RSB1	63	IO34RSB1
29	IO23RSB1	64	IO36RSB1
30	IO21RSB1	65	IO61RSB2
31	IO19RSB1	66	IO58RSB2
32	TCK	67	IO56RSB2
33	TDI	68	IO63RSB2
34	TMS		
35	VPUMP		

68-Pin QFN		68-Pin QFN	
Pin Number	AGLN020 Function	Pin Number	AGLN020 Function
1	IO60RSB2	36	TDO
2	IO54RSB2	37	TRST
3	IO52RSB2	38	VJTAG
4	IO50RSB2	39	IO17RSB0
5	IO49RSB2	40	IO16RSB0
6	GEC0/IO48RSB2	41	GDA0/IO15RSB0
7	GEA0/IO47RSB2	42	GDC0/IO14RSB0
8	VCC	43	IO13RSB0
9	GND	44	VCCIB0
10	VCCIB2	45	GND
11	IO46RSB2	46	VCC
12	IO45RSB2	47	IO12RSB0
13	IO44RSB2	48	IO11RSB0
14	IO43RSB2	49	IO09RSB0
15	IO42RSB2	50	IO05RSB0
16	IO41RSB2	51	IO00RSB0
17	IO40RSB2	52	IO07RSB0
18	FF/IO39RSB1	53	IO03RSB0
19	IO37RSB1	54	IO18RSB1
20	IO35RSB1	55	IO20RSB1
21	IO33RSB1	56	IO22RSB1
22	IO31RSB1	57	IO24RSB1
23	IO30RSB1	58	IO28RSB1
24	VCC	59	NC
25	GND	60	GND
26	VCCIB1	61	NC
27	IO27RSB1	62	IO32RSB1
28	IO25RSB1	63	IO34RSB1
29	IO23RSB1	64	IO36RSB1
30	IO21RSB1	65	IO61RSB2
31	IO19RSB1	66	IO58RSB2
32	TCK	67	IO56RSB2
33	TDI	68	IO63RSB2
34	TMS		
35	VPUMP		

68-Pin QFN		68-Pin QFN	
Pin Number	AGLN030Z Function	Pin Number	AGLN030Z Function
1	IO82RSB1	36	TDO
2	IO80RSB1	37	TRST
3	IO78RSB1	38	VJTAG
4	IO76RSB1	39	IO40RSB0
5	GEC0/IO73RSB1	40	IO37RSB0
6	GEA0/IO72RSB1	41	GDB0/IO34RSB0
7	GEB0/IO71RSB1	42	GDA0/IO33RSB0
8	VCC	43	GDC0/IO32RSB0
9	GND	44	VCCIB0
10	VCCIB1	45	GND
11	IO68RSB1	46	VCC
12	IO67RSB1	47	IO31RSB0
13	IO66RSB1	48	IO29RSB0
14	IO65RSB1	49	IO28RSB0
15	IO64RSB1	50	IO27RSB0
16	IO63RSB1	51	IO25RSB0
17	IO62RSB1	52	IO24RSB0
18	FF/IO60RSB1	53	IO22RSB0
19	IO58RSB1	54	IO21RSB0
20	IO56RSB1	55	IO19RSB0
21	IO54RSB1	56	IO17RSB0
22	IO52RSB1	57	IO15RSB0
23	IO51RSB1	58	IO14RSB0
24	VCC	59	VCCIB0
25	GND	60	GND
26	VCCIB1	61	VCC
27	IO50RSB1	62	IO12RSB0
28	IO48RSB1	63	IO10RSB0
29	IO46RSB1	64	IO08RSB0
30	IO44RSB1	65	IO06RSB0
31	IO42RSB1	66	IO04RSB0
32	TCK	67	IO02RSB0
33	TDI	68	IO00RSB0
34	TMS		
35	VPUMP		

100-Pin VQFP

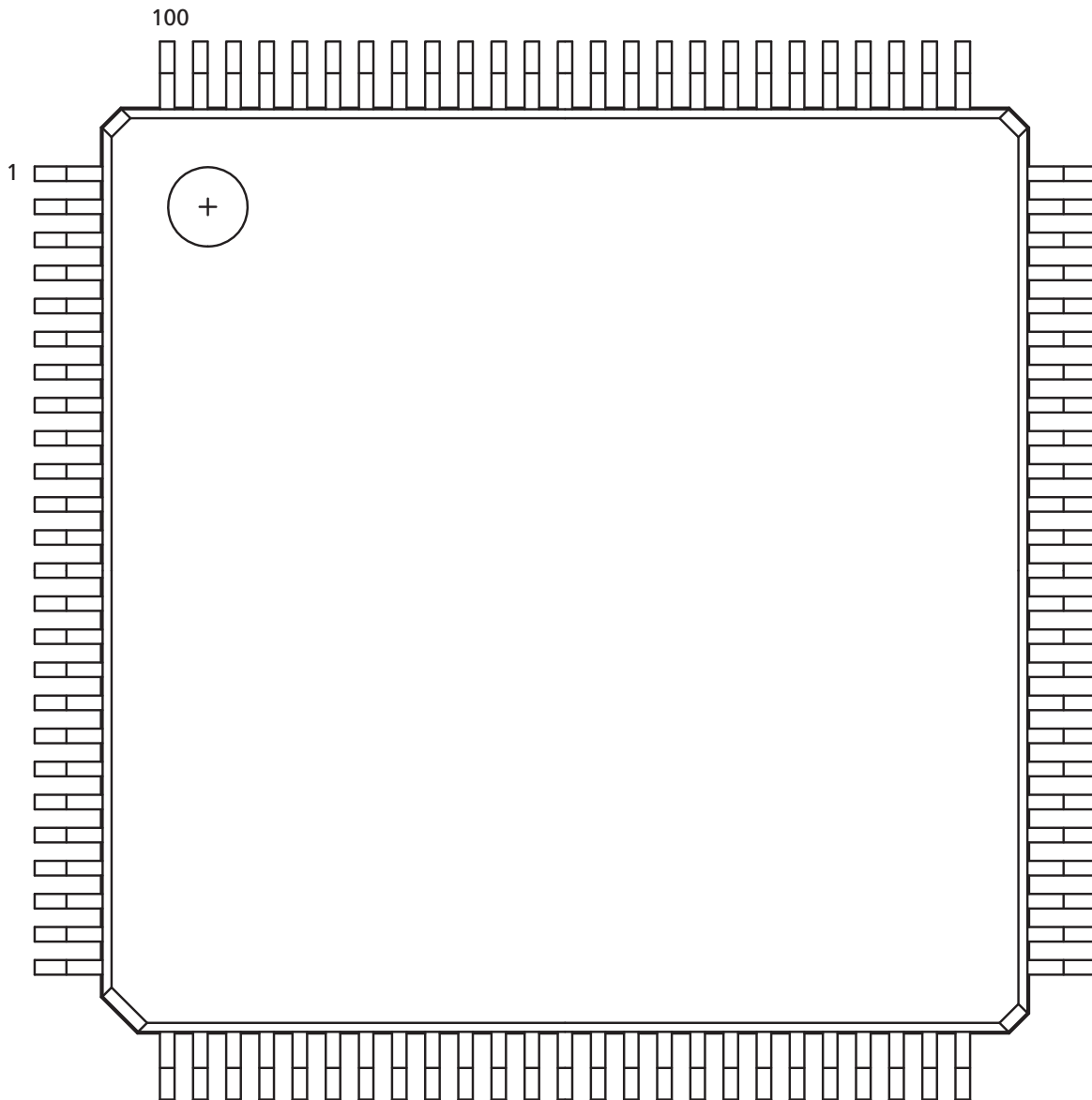

Note: This is the top view of the package.

Note

For Package Manufacturing and Environmental information, visit the Resource Center at <http://www.actel.com/products/solutions/package/docs.aspx>.

100-Pin VQFP		100-Pin VQFP		100-Pin VQFP	
Pin Number	AGLN030Z Function	Pin Number	AGLN030Z Function	Pin Number	AGLN030Z Function
1	GND	36	IO51RSB1	71	IO29RSB0
2	IO82RSB1	37	VCC	72	IO28RSB0
3	IO81RSB1	38	GND	73	IO27RSB0
4	IO80RSB1	39	VCCIB1	74	IO26RSB0
5	IO79RSB1	40	IO49RSB1	75	IO25RSB0
6	IO78RSB1	41	IO47RSB1	76	IO24RSB0
7	IO77RSB1	42	IO46RSB1	77	IO23RSB0
8	IO76RSB1	43	IO45RSB1	78	IO22RSB0
9	GND	44	IO44RSB1	79	IO21RSB0
10	IO75RSB1	45	IO43RSB1	80	IO20RSB0
11	IO74RSB1	46	IO42RSB1	81	IO19RSB0
12	GEC0/IO73RSB1	47	TCK	82	IO18RSB0
13	GEA0/IO72RSB1	48	TDI	83	IO17RSB0
14	GEB0/IO71RSB1	49	TMS	84	IO16RSB0
15	IO70RSB1	50	NC	85	IO15RSB0
16	IO69RSB1	51	GND	86	IO14RSB0
17	VCC	52	VPUMP	87	VCCIB0
18	VCCIB1	53	NC	88	GND
19	IO68RSB1	54	TDO	89	VCC
20	IO67RSB1	55	TRST	90	IO12RSB0
21	IO66RSB1	56	VJTAG	91	IO10RSB0
22	IO65RSB1	57	IO41RSB0	92	IO08RSB0
23	IO64RSB1	58	IO40RSB0	93	IO07RSB0
24	IO63RSB1	59	IO39RSB0	94	IO06RSB0
25	IO62RSB1	60	IO38RSB0	95	IO05RSB0
26	IO61RSB1	61	IO37RSB0	96	IO04RSB0
27	FF/IO60RSB1	62	IO36RSB0	97	IO03RSB0
28	IO59RSB1	63	GDB0/IO34RSB0	98	IO02RSB0
29	IO58RSB1	64	GDA0/IO33RSB0	99	IO01RSB0
30	IO57RSB1	65	GDC0/IO32RSB0	100	IO00RSB0
31	IO56RSB1	66	VCCIB0		
32	IO55RSB1	67	GND		
33	IO54RSB1	68	VCC		
34	IO53RSB1	69	IO31RSB0		
35	IO52RSB1	70	IO30RSB0		

100-Pin VQFP		100-Pin VQFP		100-Pin VQFP	
Pin Number	AGLN060 Function	Pin Number	AGLN060 Function	Pin Number	AGLN060 Function
1	GND	36	IO61RSB1	71	GBB2/IO27RSB0
2	GAA2/IO51RSB1	37	VCC	72	IO26RSB0
3	IO52RSB1	38	GND	73	GBA2/IO25RSB0
4	GAB2/IO53RSB1	39	VCCIB1	74	VMV0
5	IO95RSB1	40	IO60RSB1	75	GNDQ
6	GAC2/IO94RSB1	41	IO59RSB1	76	GBA1/IO24RSB0
7	IO93RSB1	42	IO58RSB1	77	GBA0/IO23RSB0
8	IO92RSB1	43	IO57RSB1	78	GBB1/IO22RSB0
9	GND	44	GDC2/IO56RSB1	79	GBB0/IO21RSB0
10	GFB1/IO87RSB1	45*	GDB2/IO55RSB1	80	GBC1/IO20RSB0
11	GFB0/IO86RSB1	46	GDA2/IO54RSB1	81	GBC0/IO19RSB0
12	VCOMPLF	47	TCK	82	IO18RSB0
13	GFA0/IO85RSB1	48	TDI	83	IO17RSB0
14	VCCPLF	49	TMS	84	IO15RSB0
15	GFA1/IO84RSB1	50	VMV1	85	IO13RSB0
16	GFA2/IO83RSB1	51	GND	86	IO11RSB0
17	VCC	52	VPUMP	87	VCCIB0
18	VCCIB1	53	NC	88	GND
19	GEC1/IO77RSB1	54	TDO	89	VCC
20	GEB1/IO75RSB1	55	TRST	90	IO10RSB0
21	GEB0/IO74RSB1	56	VJTAG	91	IO09RSB0
22	GEA1/IO73RSB1	57	GDA1/IO49RSB0	92	IO08RSB0
23	GEA0/IO72RSB1	58	GDC0/IO46RSB0	93	GAC1/IO07RSB0
24	VMV1	59	GDC1/IO45RSB0	94	GAC0/IO06RSB0
25	GNDQ	60	GCC2/IO43RSB0	95	GAB1/IO05RSB0
26	GEA2/IO71RSB1	61	GCB2/IO42RSB0	96	GAB0/IO04RSB0
27	FF/GEB2/IO70RSB1	62	GCA0/IO40RSB0	97	GAA1/IO03RSB0
28	GEC2/IO69RSB1	63	GCA1/IO39RSB0	98	GAA0/IO02RSB0
29	IO68RSB1	64	GCC0/IO36RSB0	99	IO01RSB0
30	IO67RSB1	65	GCC1/IO35RSB0	100	IO00RSB0
31	IO66RSB1	66	VCCIB0		
32	IO65RSB1	67	GND		
33	IO64RSB1	68	VCC		
34	IO63RSB1	69	IO31RSB0		
35	IO62RSB1	70	GBC2/IO29RSB0		

Note: *The bus hold attribute (hold previous I/O state in Flash*Freeze mode) is not supported for pin 45 in AGLN060-VQ100.

100-Pin VQFP		100-Pin VQFP		100-Pin VQFP	
Pin Number	AGLN060Z Function	Pin Number	AGLN060Z Function	Pin Number	AGLN060Z Function
1	GND	35	IO62RSB1	69	IO31RSB0
2	GAA2/IO51RSB1	36	IO61RSB1	70	GBC2/IO29RSB0
3	IO52RSB1	37	VCC	71	GBB2/IO27RSB0
4	GAB2/IO53RSB1	38	GND	72	IO26RSB0
5	IO95RSB1	39	VCCIB1	73	GBA2/IO25RSB0
6	GAC2/IO94RSB1	40	IO60RSB1	74	VMV0
7	IO93RSB1	41	IO59RSB1	75	GNDQ
8	IO92RSB1	42	IO58RSB1	76	GBA1/IO24RSB0
9	GND	43	IO57RSB1	77	GBA0/IO23RSB0
10	GFB1/IO87RSB1	44	GDC2/IO56RSB1	78	GBB1/IO22RSB0
11	GFB0/IO86RSB1	45*	GDB2/IO55RSB1	79	GBB0/IO21RSB0
12	VCOMPLF	46	GDA2/IO54RSB1	80	GBC1/IO20RSB0
13	GFA0/IO85RSB1	47	TCK	81	GBC0/IO19RSB0
14	VCCPLF	48	TDI	82	IO18RSB0
15	GFA1/IO84RSB1	49	TMS	83	IO17RSB0
16	GFA2/IO83RSB1	50	VMV1	84	IO15RSB0
17	VCC	51	GND	85	IO13RSB0
18	VCCIB1	52	VPUMP	86	IO11RSB0
19	GEC1/IO77RSB1	53	NC	87	VCCIB0
20	GEB1/IO75RSB1	54	TDO	88	GND
21	GEB0/IO74RSB1	55	TRST	89	VCC
22	GEA1/IO73RSB1	56	VJTAG	90	IO10RSB0
23	GEA0/IO72RSB1	57	GDA1/IO49RSB0	91	IO09RSB0
24	VMV1	58	GDC0/IO46RSB0	92	IO08RSB0
25	GNDQ	59	GDC1/IO45RSB0	93	GAC1/IO07RSB0
26	GEA2/IO71RSB1	60	GCC2/IO43RSB0	94	GAC0/IO06RSB0
27	FF/GEB2/IO70RSB1	61	GCB2/IO42RSB0	95	GAB1/IO05RSB0
28	GEC2/IO69RSB1	62	GCA0/IO40RSB0	96	GAB0/IO04RSB0
29	IO68RSB1	63	GCA1/IO39RSB0	97	GAA1/IO03RSB0
30	IO67RSB1	64	GCC0/IO36RSB0	98	GAA0/IO02RSB0
31	IO66RSB1	65	GCC1/IO35RSB0	99	IO01RSB0
32	IO65RSB1	66	VCCIB0	100	IO00RSB0
33	IO64RSB1	67	GND		
34	IO63RSB1	68	VCC		

Note: *The bus hold attribute (hold previous I/O state in Flash*Freeze mode) is not supported for pin 45 in AGLN060Z-VQ100.

100-Pin VQFP		100-Pin VQFP		100-Pin VQFP	
Pin Number	AGLN125 Function	Pin Number	AGLN125 Function	Pin Number	AGLN125 Function
1	GND	36	IO93RSB1	71	GBB2/IO43RSB0
2	GAA2/IO67RSB1	37	VCC	72	IO42RSB0
3	IO68RSB1	38	GND	73	GBA2/IO41RSB0
4	GAB2/IO69RSB1	39	VCCIB1	74	VMV0
5	IO132RSB1	40	IO87RSB1	75	GNDQ
6	GAC2/IO131RSB1	41	IO84RSB1	76	GBA1/IO40RSB0
7	IO130RSB1	42	IO81RSB1	77	GBA0/IO39RSB0
8	IO129RSB1	43	IO75RSB1	78	GBB1/IO38RSB0
9	GND	44	GDC2/IO72RSB1	79	GBB0/IO37RSB0
10	GFB1/IO124RSB1	45	GDB2/IO71RSB1	80	GBC1/IO36RSB0
11	GFB0/IO123RSB1	46	GDA2/IO70RSB1	81	GBC0/IO35RSB0
12	VCOMPLF	47	TCK	82	IO32RSB0
13	GFA0/IO122RSB1	48	TDI	83	IO28RSB0
14	VCCPLF	49	TMS	84	IO25RSB0
15	GFA1/IO121RSB1	50	VMV1	85	IO22RSB0
16	GFA2/IO120RSB1	51	GND	86	IO19RSB0
17	VCC	52	VPUMP	87	VCCIB0
18	VCCIB1	53	NC	88	GND
19	GEC0/IO111RSB1	54	TDO	89	VCC
20	GEB1/IO110RSB1	55	TRST	90	IO15RSB0
21	GEB0/IO109RSB1	56	VJTAG	91	IO13RSB0
22	GEA1/IO108RSB1	57	GDA1/IO65RSB0	92	IO11RSB0
23	GEA0/IO107RSB1	58	GDC0/IO62RSB0	93	IO09RSB0
24	VMV1	59	GDC1/IO61RSB0	94	IO07RSB0
25	GNDQ	60	GCC2/IO59RSB0	95	GAC1/IO05RSB0
26	GEA2/IO106RSB1	61	GCB2/IO58RSB0	96	GAC0/IO04RSB0
27	FF/GEB2/IO105RSB1	62	GCA0/IO56RSB0	97	GAB1/IO03RSB0
28	GEC2/IO104RSB1	63	GCA1/IO55RSB0	98	GAB0/IO02RSB0
29	IO102RSB1	64	GCC0/IO52RSB0	99	GAA1/IO01RSB0
30	IO100RSB1	65	GCC1/IO51RSB0	100	GAA0/IO00RSB0
31	IO99RSB1	66	VCCIB0		
32	IO97RSB1	67	GND		
33	IO96RSB1	68	VCC		
34	IO95RSB1	69	IO47RSB0		
35	IO94RSB1	70	GBC2/IO45RSB0		

100-Pin VQFP		100-Pin VQFP		100-Pin VQFP	
Pin Number	AGLN125Z Function	Pin Number	AGLN125Z Function	Pin Number	AGLN125Z Function
1	GND	36	IO93RSB1	71	GBB2/IO43RSB0
2	GAA2/IO67RSB1	37	VCC	72	IO42RSB0
3	IO68RSB1	38	GND	73	GBA2/IO41RSB0
4	GAB2/IO69RSB1	39	VCCIB1	74	VMV0
5	IO132RSB1	40	IO87RSB1	75	GNDQ
6	GAC2/IO131RSB1	41	IO84RSB1	76	GBA1/IO40RSB0
7	IO130RSB1	42	IO81RSB1	77	GBA0/IO39RSB0
8	IO129RSB1	43	IO75RSB1	78	GBB1/IO38RSB0
9	GND	44	GDC2/IO72RSB1	79	GBB0/IO37RSB0
10	GFB1/IO124RSB1	45	GDB2/IO71RSB1	80	GBC1/IO36RSB0
11	GFB0/IO123RSB1	46	GDA2/IO70RSB1	81	GBC0/IO35RSB0
12	VCOMPLF	47	TCK	82	IO32RSB0
13	GFA0/IO122RSB1	48	TDI	83	IO28RSB0
14	VCCPLF	49	TMS	84	IO25RSB0
15	GFA1/IO121RSB1	50	VMV1	85	IO22RSB0
16	GFA2/IO120RSB1	51	GND	86	IO19RSB0
17	VCC	52	VPUMP	87	VCCIB0
18	VCCIB1	53	NC	88	GND
19	GEC0/IO111RSB1	54	TDO	89	VCC
20	GEB1/IO110RSB1	55	TRST	90	IO15RSB0
21	GEB0/IO109RSB1	56	VJTAG	91	IO13RSB0
22	GEA1/IO108RSB1	57	GDA1/IO65RSB0	92	IO11RSB0
23	GEA0/IO107RSB1	58	GDC0/IO62RSB0	93	IO09RSB0
24	VMV1	59	GDC1/IO61RSB0	94	IO07RSB0
25	GNDQ	60	GCC2/IO59RSB0	95	GAC1/IO05RSB0
26	GEA2/IO106RSB1	61	GCB2/IO58RSB0	96	GAC0/IO04RSB0
27	FF/GEB2/IO105RSB1	62	GCA0/IO56RSB0	97	GAB1/IO03RSB0
28	GEC2/IO104RSB1	63	GCA1/IO55RSB0	98	GAB0/IO02RSB0
29	IO102RSB1	64	GCC0/IO52RSB0	99	GAA1/IO01RSB0
30	IO100RSB1	65	GCC1/IO51RSB0	100	GAA0/IO00RSB0
31	IO99RSB1	66	VCCIB0		
32	IO97RSB1	67	GND		
33	IO96RSB1	68	VCC		
34	IO95RSB1	69	IO47RSB0		
35	IO94RSB1	70	GBC2/IO45RSB0		

100-Pin VQFP		100-Pin VQFP		100-Pin VQFP	
Pin Number	AGLN250 Function	Pin Number	AGLN250 Function	Pin Number	AGLN250 Function
1	GND	37	VCC	73	GBA2/IO20RSB1
2	GAA2/IO67RSB3	38	GND	74	VMV1
3	IO66RSB3	39	VCCIB2	75	GNDQ
4	GAB2/IO65RSB3	40	IO39RSB2	76	GBA1/IO19RSB0
5	IO64RSB3	41	IO38RSB2	77	GBA0/IO18RSB0
6	GAC2/IO63RSB3	42	IO37RSB2	78	GGB1/IO17RSB0
7	IO62RSB3	43	GDC2/IO36RSB2	79	GGB0/IO16RSB0
8	IO61RSB3	44	GDB2/IO35RSB2	80	GBC1/IO15RSB0
9	GND	45	GDA2/IO34RSB2	81	GBC0/IO14RSB0
10	GFB1/IO60RSB3	46	GNDQ	82	IO13RSB0
11	GFB0/IO59RSB3	47	TCK	83	IO12RSB0
12	VCOMPLF	48	TDI	84	IO11RSB0
13	GFA0/IO57RSB3	49	TMS	85	IO10RSB0
14	VCCPLF	50	VMV2	86	IO09RSB0
15	GFA1/IO58RSB3	51	GND	87	VCCIB0
16	GFA2/IO56RSB3	52	VPUMP	88	GND
17	VCC	53	NC	89	VCC
18	VCCIB3	54	TDO	90	IO08RSB0
19	GFC2/IO55RSB3	55	TRST	91	IO07RSB0
20	GEC1/IO54RSB3	56	VJTAG	92	IO06RSB0
21	GEC0/IO53RSB3	57	GDA1/IO33RSB1	93	GAC1/IO05RSB0
22	GEA1/IO52RSB3	58	GDC0/IO32RSB1	94	GAC0/IO04RSB0
23	GEA0/IO51RSB3	59	GDC1/IO31RSB1	95	GAB1/IO03RSB0
24	VMV3	60	IO30RSB1	96	GAB0/IO02RSB0
25	GNDQ	61	GCB2/IO29RSB1	97	GAA1/IO01RSB0
26	GEA2/IO50RSB2	62	GCA1/IO27RSB1	98	GAA0/IO00RSB0
27	FF/GE2/IO49RSB2	63	GCA0/IO28RSB1	99	GNDQ
28	GEC2/IO48RSB2	64	GCC0/IO26RSB1	100	VMV0
29	IO47RSB2	65	GCC1/IO25RSB1		
30	IO46RSB2	66	VCCIB1		
31	IO45RSB2	67	GND		
32	IO44RSB2	68	VCC		
33	IO43RSB2	69	IO24RSB1		
34	IO42RSB2	70	GBC2/IO23RSB1		
35	IO41RSB2	71	GGB2/IO22RSB1		
36	IO40RSB2	72	IO21RSB1		

100-Pin VQFP		100-Pin VQFP		100-Pin VQFP	
Pin Number	AGLN250Z Function	Pin Number	AGLN250Z Function	Pin Number	AGLN250Z Function
1	GND	37	VCC	73	GBA2/IO20RSB1
2	GAA2/IO67RSB3	38	GND	74	VMV1
3	IO66RSB3	39	VCCIB2	75	GNDQ
4	GAB2/IO65RSB3	40	IO39RSB2	76	GBA1/IO19RSB0
5	IO64RSB3	41	IO38RSB2	77	GBA0/IO18RSB0
6	GAC2/IO63RSB3	42	IO37RSB2	78	GBB1/IO17RSB0
7	IO62RSB3	43	GDC2/IO36RSB2	79	GBB0/IO16RSB0
8	IO61RSB3	44	GDB2/IO35RSB2	80	GBC1/IO15RSB0
9	GND	45	GDA2/IO34RSB2	81	GBC0/IO14RSB0
10	GFB1/IO60RSB3	46	GNDQ	82	IO13RSB0
11	GFB0/IO59RSB3	47	TCK	83	IO12RSB0
12	VCOMPLF	48	TDI	84	IO11RSB0
13	GFA0/IO57RSB3	49	TMS	85	IO10RSB0
14	VCCPLF	50	VMV2	86	IO09RSB0
15	GFA1/IO58RSB3	51	GND	87	VCCIB0
16	GFA2/IO56RSB3	52	VPUMP	88	GND
17	VCC	53	NC	89	VCC
18	VCCIB3	54	TDO	90	IO08RSB0
19	GFC2/IO55RSB3	55	TRST	91	IO07RSB0
20	GEC1/IO54RSB3	56	VJTAG	92	IO06RSB0
21	GEC0/IO53RSB3	57	GDA1/IO33RSB1	93	GAC1/IO05RSB0
22	GEA1/IO52RSB3	58	GDC0/IO32RSB1	94	GAC0/IO04RSB0
23	GEA0/IO51RSB3	59	GDC1/IO31RSB1	95	GAB1/IO03RSB0
24	VMV3	60	IO30RSB1	96	GAB0/IO02RSB0
25	GNDQ	61	GCB2/IO29RSB1	97	GAA1/IO01RSB0
26	GEA2/IO50RSB2	62	GCA1/IO27RSB1	98	GAA0/IO00RSB0
27	FF/GEA2/IO49RSB2	63	GCA0/IO28RSB1	99	GNDQ
28	GEC2/IO48RSB2	64	GCC0/IO26RSB1	100	VMV0
29	IO47RSB2	65	GCC1/IO25RSB1		
30	IO46RSB2	66	VCCIB1		
31	IO45RSB2	67	GND		
32	IO44RSB2	68	VCC		
33	IO43RSB2	69	IO24RSB1		
34	IO42RSB2	70	GBC2/IO23RSB1		
35	IO41RSB2	71	GBB2/IO22RSB1		
36	IO40RSB2	72	IO21RSB1		

4 – Datasheet Information

List of Changes

The following table lists critical changes that were made in each version of the IGLOO nano datasheet.

Revision	Changes	Page
Revision 10 (April 2010)	References to differential inputs were removed from the datasheet, since IGLOO nano devices do not support differential inputs (SAR 21449).	N/A
	A parenthetical note, "hold previous I/O state in Flash*Freeze mode," was added to each occurrence of bus hold in the datasheet (SAR 24079).	N/A
	The "In-System Programming (ISP) and Security" section was revised to add 1.2 V programming.	I
	The note connected with the "IGLOO nano Ordering Information" table was revised to clarify features not available for Z feature grade devices.	III
	The "IGLOO nano Device Status" table is new.	II
	The definition of C in the "Temperature Grade Offerings" table was changed to "extended commercial temperature range."	IV
	1.2 V wide range was added to the list of voltage ranges in the "I/Os with Advanced I/O Standards" section.	1-8
	A note was added to Table 2-2 • Recommended Operating Conditions 1 regarding switching from 1.2 V to 1.5 V core voltage for in-system programming. The VJTAG voltage was changed from "1.425 to 3.6" to "1.4 to 3.6" (SAR 24052). The note regarding voltage for programming V2 and V5 devices was revised (SAR 25213). The maximum value for VPUMP programming voltage (operation mode) was changed from 3.45 V to 3.6 V (SAR 25220).	2-2
	Table 2-6 • Temperature and Voltage Derating Factors for Timing Delays (normalized to $T_J = 70^\circ\text{C}$, $V_{CC} = 1.425\text{ V}$) and Table 2-7 • Temperature and Voltage Derating Factors for Timing Delays (normalized to $T_J = 70^\circ\text{C}$, $V_{CC} = 1.14\text{ V}$) were updated. Table 2-8 • Power Supply State per Mode is new.	2-6, 2-7
	The tables in the "Quiescent Supply Current" section were updated (SAR 24882 and SAR 24112).	2-7
	VJTAG was removed from Table 2-10 • Quiescent Supply Current (IDD) Characteristics, IGLOO nano Sleep Mode* (SARs 24112, 24882, and 79503).	2-8
	The note stating what was included in I_{DD} was removed from Table 2-11 • Quiescent Supply Current (IDD) Characteristics, IGLOO nano Shutdown Mode. The note, "per VCCI or VJTAG bank" was removed from Table 2-12 • Quiescent Supply Current (IDD), No IGLOO nano Flash*Freeze Mode ¹ . The note giving I_{DD} was changed to " $I_{DD} = N_{\text{BANKS}} * I_{\text{CCI}} + I_{\text{CCA}}$."	2-8
The values in Table 2-13 • Summary of I/O Input Buffer Power (per pin) – Default I/O Software Settings and Table 2-14 • Summary of I/O Output Buffer Power (per pin) – Default I/O Software Settings ¹ were updated. Wide range support information was added.	2-9	

Revision	Changes	Page
Revision 10 (continued)	<p>The following tables were updated with current available information. The equivalent software default drive strength option was added.</p> <p>Table 2-21 • Summary of Maximum and Minimum DC Input and Output Levels</p> <p>Table 2-25 • Summary of I/O Timing Characteristics—Software Default Settings</p> <p>Table 2-26 • Summary of I/O Timing Characteristics—Software Default Settings</p> <p>Table 2-28 • I/O Output Buffer Maximum Resistances 1</p> <p>Table 2-29 • I/O Weak Pull-Up/Pull-Down Resistances</p> <p>Table 2-30 • I/O Short Currents IOSH/IOSL</p> <p>Timing tables in the "Single-Ended I/O Characteristics" section, including new tables for 3.3 V and 1.2 V LVCMOS wide range.</p> <p>Table 2-40 • Minimum and Maximum DC Input and Output Levels for LVCMOS 3.3 V Wide Range</p> <p>Table 2-63 • Minimum and Maximum DC Input and Output Levels</p> <p>Table 2-67 • Minimum and Maximum DC Input and Output Levels (new)</p>	2-19 through 2-40
	The formulas in the notes to Table 2-29 • I/O Weak Pull-Up/Pull-Down Resistances were revised (SAR 21348).	2-24
	The text introducing Table 2-31 • Duration of Short Circuit Event before Failure was revised to state six months at 100° instead of three months at 110° for reliability concerns. The row for 110° was removed from the table.	2-25
	The following sentence was deleted from the "2.5 V LVCMOS" section (SAR 24916): "It uses a 5-V tolerant input buffer and push-pull output buffer."	2-32
	The $F_{DDRIMAX}$ and F_{DDOMAX} values were added to tables in the "DDR Module Specifications" section (SAR 23919). A note was added stating that DDR is not supported for AGLN010, AGLN015, and AGLN020.	2-51
	Tables in the "Global Tree Timing Characteristics" section were updated with new information available.	2-64
	Table 2-101 • IGLOO nano CCC/PLL Specification and Table 2-102 • IGLOO nano CCC/PLL Specification were revised (SAR 79390).	2-70, 2-71
	Tables in the SRAM "Timing Characteristics" section and FIFO "Timing Characteristics" section were updated with new information available.	2-77, 2-84
	Table 3-3 • TRST and TCK Pull-Down Recommendations is new.	3-5
	A note was added to the "81-Pin CS" pin tables for AGLN060, AGLN060Z, AGLN125, AGLN125Z, AGLN250, and AGLN250Z indicating that pins F1 and F2 must be grounded (SAR 25007).	3-9, through 3-14
	A note was added to the "81-Pin CS" and "100-Pin VQFP" pin tables for AGLN060 and AGLN060Z stating that bus hold is not available for pin H7 or pin 45 (SAR 24079).	3-9, 3-24
	The AGLN250 function for pin C8 in the "81-Pin CS" table was revised (SAR 22134).	3-13
Revision 9 (March 2010)	All product tables and pin tables were updated to show clearly that AGLN030 is available only in the Z feature grade at this time. The nano-Z feature grade devices are designated with a Z at the end of the part number.	N/A

Revision	Changes	Page
Revision 8 (January 2009)	The "Reprogrammable Flash Technology" section was revised to add "250 MHz (1.5 V systems) and 160 MHz (1.2 V systems) System Performance."	I
	The note for AGLN030 in the "IGLOO nano Devices" table and "I/Os Per Package" table was revised to remove the statement regarding package compatibility with lower density nano devices.	II, II
	The "I/Os with Advanced I/O Standards" section was revised to add definitions for hot-swap and cold-sparing.	1-8
	Reference to the –F speed grade was removed from the "IGLOO nano DC and Switching Characteristics" section, since it is no longer offered for IGLOO nano devices.	2-1
	The "81-Pin UC", "81-Pin CS", "48-Pin QFN", and "68-Pin QFN" pin tables for AGLN030 are new.	3-5, 3-8, 3-17, 3-21
	The "81-Pin CS" pin table for AGLN060 is new.	3-9
	The "81-Pin CS" and "100-Pin VQFP" pin tables for AGLN060Z are new.	3-10, 3-25
	The "81-Pin CS" and "100-Pin VQFP" pin tables for AGLN125Z are new.	3-12, 3-27
	The "81-Pin CS" and "100-Pin VQFP" pin tables for AGLN250Z is new.	3-14, 3-29
Revision 7 (April 2009)	The –F speed grade is no longer offered for IGLOO nano devices. The speed grade column and note regarding –F speed grade were removed from "IGLOO nano Ordering Information". The "Speed Grade and Temperature Grade Matrix" section was removed.	III, IV
Revision 6 (March 2009)	The "100-Pin VQFP" pin table for AGLN030 is new.	3-23
Revision 5 (February 2009)	The "100-Pin QFN" section was removed.	N/A
Revision 4 (February 2009)	The QN100 package was removed for all devices.	N/A
	"IGLOO nano Devices" table was updated to change the maximum user I/Os for AGLN030 from 81 to 77.	II
	The "Device Marking" section is new.	III
Revision 3 (February 2009)	The following table note was removed from "IGLOO nano Devices" table: "Six chip (main) and three quadrant global networks are available for AGLN060 and above."	II
	The CS81 package was added for AGLN250 in the "IGLOO nano Product Available in the Z Feature Grade" table.	IV
	The "81-Pin UC" and "81-Pin CS" pin tables for AGLN020 are new.	3-4, 3-7
	The "81-Pin CS" pin table for AGLN250 is new.	3-13
Revision 2 (December 2008)	The second table note in "IGLOO nano Devices" table was revised to state, "AGLN060, AGLN125, and AGLN250 in the CS81 package do not support PLLs. AGLN030 and smaller devices do not support this feature."	II
	The I/Os per package for CS81 were revised to 60 for AGLN060, AGLN125, and AGLN250 in the "I/Os Per Package" table.	II
	The "36-Pin UC" pin table is new.	3-2

Revision	Changes	Page
Revision 1 (November 2008)	The "Advanced I/Os" section was updated to include wide power supply voltage support for 1.14 V to 1.575 V.	I
	The AGLN030 device was added to product tables and replaces AGL030 entries that were formerly in the tables.	IV
	The "I/Os Per Package" table was updated for the CS81 package to change the number of I/Os for AGLN060, AGLN125, and AGLN250 from 66 to 64.	II
	The "Wide Range I/O Support" section is new.	1-8
	The following tables and sections were updated to add the UC81 and CS81 packages for AGL030: "IGLOO nano Devices" "I/Os Per Package" "IGLOO nano Product Available in the Z Feature Grade" "Temperature Grade Offerings"	N/A
	The "I/Os Per Package" table was updated to add the following information to table note 4: "For nano devices, the VQ100 package is offered in both leaded and RoHS-compliant versions. All other packages are RoHS-compliant only."	II
	The "IGLOO nano Product Available in the Z Feature Grade" section was updated to remove QN100 for AGLN250.	IV
	The device architecture figures, Figure 1-3 • IGLOO Device Architecture Overview with Two I/O Banks (AGLN060, AGLN125) through Figure 1-4 • IGLOO Device Architecture Overview with Four I/O Banks (AGLN250), were revised. Figure 1-1 • IGLOO Device Architecture Overview with Two I/O Banks and No RAM (AGLN010 and AGLN030) is new.	1-4 through 1-5
	The "PLL and CCC" section was revised to include information about CCC-GLs in AGLN020 and smaller devices.	1-7
	The "I/Os with Advanced I/O Standards" section was revised to add information about IGLOO nano devices supporting double-data-rate applications.	1-8
	The table notes and references were revised in Table 2-2 • Recommended Operating Conditions 1. VMV was included with VCCI and a table note was added stating, "VMV pins must be connected to the corresponding VCCI pins. See Pin Descriptions for further information." Please review carefully.	2-2
	VJTAG was added to the list in the table note for Table 2-9 • Quiescent Supply Current (IDD) Characteristics, IGLOO nano Flash*Freeze Mode*. Values were added for AGLN010, AGLN015, and AGLN030 for 1.5 V.	2-7
	VCCI was removed from the list in the table note for Table 2-10 • Quiescent Supply Current (IDD) Characteristics, IGLOO nano Sleep Mode*.	2-8
	Values for I _{CCA} current were updated for AGLN010, AGLN015, and AGLN030 in Table 2-12 • Quiescent Supply Current (IDD), No IGLOO nano Flash*Freeze Mode1.	2-8
Values for PAC1 and PAC2 were added to Table 2-15 • Different Components Contributing to Dynamic Power Consumption in IGLOO nano Devices and Table 2-17 • Different Components Contributing to Dynamic Power Consumption in IGLOO nano Devices.	2-10, 2-11	
Table notes regarding wide range support were added to Table 2-21 • Summary of Maximum and Minimum DC Input and Output Levels.	2-19	

Revision	Changes	Page
Revision 1 (continued)	1.2 V LVCMOS wide range values were added to Table 2-22 • Summary of Maximum and Minimum DC Input Levels and Table 2-23 • Summary of AC Measuring Points .	2-19, 2-20
	The following table note was added to Table 2-25 • Summary of I/O Timing Characteristics—Software Default Settings and Table 2-26 • Summary of I/O Timing Characteristics—Software Default Settings : "All LVCMOS 3.3 V software macros support LVCMOS 3.3 V wide range, as specified in the JESD8-B specification."	2-21
	3.3 V LVCMOS Wide Range and 1.2 V Wide Range were added to Table 2-28 • I/O Output Buffer Maximum Resistances 1 and Table 2-30 • I/O Short Currents IOSH/IOSL .	2-23, 2-24
	The "48-Pin QFN" pin diagram was revised.	3-16
	Note 2 for the "48-Pin QFN", "68-Pin QFN", and "100-Pin QFN" pin diagrams was changed to "The die attach paddle of the package is tied to ground (GND)."	3-16, 3-19
	The "100-Pin VQFP" pin diagram was revised to move the pin IDs to the upper left corner instead of the upper right corner.	3-23

Datasheet Categories

Categories

In order to provide the latest information to designers, some datasheet parameters are published before data has been fully characterized from silicon devices. The data provided for a given device, as highlighted in the "IGLOO nano Device Status" table on page II, is designated as either "Product Brief," "Advance," "Preliminary," or "Production." The definitions of these categories are as follows:

Product Brief

The product brief is a summarized version of a datasheet (advance or production) and contains general product information. This document gives an overview of specific device and family information.

Advance

This version contains initial estimated information based on simulation, other products, devices, or speed grades. This information can be used as estimates, but not for production. This label only applies to the DC and Switching Characteristics chapter of the datasheet and will only be used when the data has not been fully characterized.

Preliminary

The datasheet contains information based on simulation and/or initial characterization. The information is believed to be correct, but changes are possible.

Unmarked (production)

This version contains information that is considered to be final.

Export Administration Regulations (EAR)

The products described in this document are subject to the Export Administration Regulations (EAR). They could require an approved export license prior to export from the United States. An export includes release of product or disclosure of technology to a foreign national inside or outside the United States.

Actel Safety Critical, Life Support, and High-Reliability Applications Policy

The Actel products described in this advance status document may not have completed Actel's qualification process. Actel may amend or enhance products during the product introduction and qualification process, resulting in changes in device functionality or performance. It is the responsibility of each customer to ensure the fitness of any Actel product (but especially a new product) for a particular purpose, including appropriateness for safety-critical, life-support, and other high-reliability applications. Consult Actel's Terms and Conditions for specific liability exclusions relating to life-support applications. A reliability report covering all of Actel's products is available on the Actel website at http://www.actel.com/documents/ORT_Report.pdf. Actel also offers a variety of enhanced qualification and lot acceptance screening procedures. Contact your local Actel sales office for additional reliability information.



Actel is the leader in low power FPGAs and mixed signal FPGAs and offers the most comprehensive portfolio of system and power management solutions. Power Matters. Learn more at www.actel.com.

Actel Corporation

2061 Stierlin Court
Mountain View, CA
94043-4655 USA
Phone 650.318.4200
Fax 650.318.4600

Actel Europe Ltd.

River Court, Meadows Business Park
Station Approach, Blackwater
Camberley Surrey GU17 9AB
United Kingdom
Phone +44 (0) 1276 609 300
Fax +44 (0) 1276 607 540

Actel Japan

EXOS Ebisu Building 4F
1-24-14 Ebisu Shibuya-ku
Tokyo 150 Japan
Phone +81.03.3445.7671
Fax +81.03.3445.7668
<http://jp.actel.com>

Actel Hong Kong

Room 2107, China Resources Building
26 Harbour Road
Wanchai, Hong Kong
Phone +852 2185 6460
Fax +852 2185 6488
www.actel.com.cn